



PRT-4G-USB

Protege DIN Rail Cellular Modem

Installation Manual



The specifications and descriptions of products and services contained in this document were correct at the time of printing. Integrated Control Technology Limited reserves the right to change specifications or withdraw products without notice. No part of this document may be reproduced, photocopied, or transmitted in any form or by any means (electronic or mechanical), for any purpose, without the express written permission of Integrated Control Technology Limited. Designed and manufactured by Integrated Control Technology Limited, Protege® and the Protege® Logo are registered trademarks of Integrated Control Technology Limited. All other brand or product names are trademarks or registered trademarks of their respective holders.

Copyright © Integrated Control Technology Limited 2003-2026. All rights reserved.

Last Published: 20-Jan-26 11:52 AM

Contents

Introduction	5
About This Module	5
Controller Prerequisites	6
Controller Hardware	6
Controller Firmware	6
Installation Requirements	7
Grounding Requirements	8
Safety Grounding	8
Earth Ground Connection	8
Mounting	10
Removal	10
Connections	11
Power Requirements	11
USB Connection	11
Antenna Connection	12
SIM	12
LED Indicator	13
Mechanical Diagram	14
Mechanical Layout	15
Technical Specifications	16
New Zealand and Australia	18
European Standards	19
UK Conformity Assessment Mark	21
UL and cUL Installation Requirements	22
UL/cUL Enclosures	22
Central Station Signal Receiver Compatibility List	22
UL Operation Mode	22
cUL Compliance Requirements	22
CAN/ULC-60839-11-1	22
CAN/ULC-S304	23
CAN/ULC-S559	26
UL Compliance Requirements	30
UL1610	30
UL294	31

FCC Compliance Statements	33
Industry Canada Statement	34
Disclaimer and Warranty	35

Introduction

This installation manual provides instructions and technical specifications for physical installation of the Protege DIN Rail Cellular Modem. For programming and operating information, see the Protege DIN Rail Cellular Modem Configuration Guide, available from the ICT website.

About This Module

The Protege DIN Rail Cellular Modem is a cellular communication device that provides a convenient wireless connection for a Protege controller.

For Protege WX controllers this device can provide wireless IP alarm transmission capability, allowing communication of alarms from a controller to a monitoring station via cellular network transmission for convenient, cost-effective monitored outbound reporting.

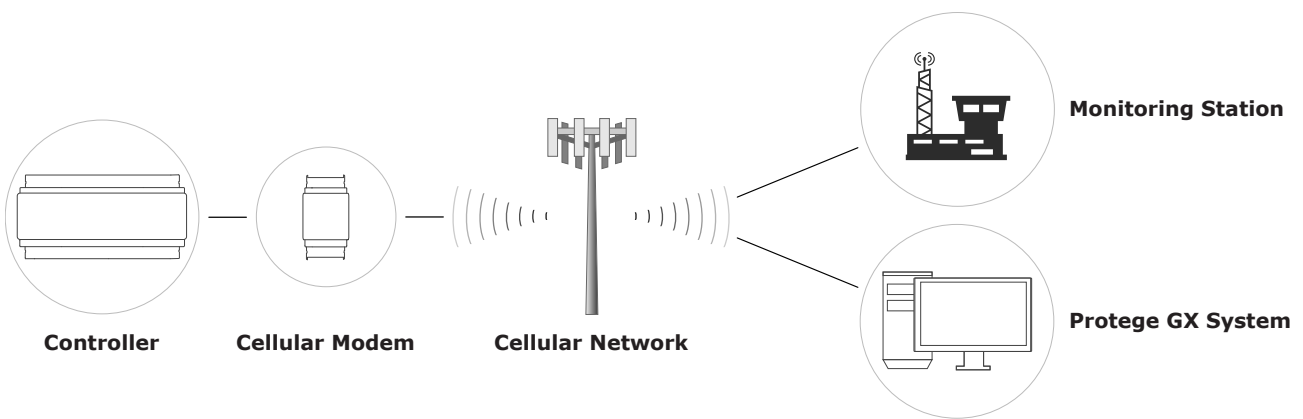

For Protege GX controllers this device can provide wireless IP alarm transmission capability, and on supported networks can also facilitate programming downloads and manual control from the Protege GX system, and event uploads to the Protege GX events database.

With no physical network required this is an ideal solution for remote sites and installations where network infrastructure may be unavailable, or difficult and expensive to install.

The current features of the DIN Rail Cellular Modem include:

- Category M-1 cellular network capability with fallback to 2G GSM
- Secure encrypted communications via the Report IP service
- Continuous connection detection and automatic fail reset
- 1 LED indicator
- 1 Micro-SIM card holder
- 1 SMA antenna connection
- 1 USB-C port
- 1 4G antenna (included)
- 1 USB-A to USB-C connector cable (included)
- Industry standard DIN rail mounting
- Convenient 1/4 DIN footprint

Controller Prerequisites

Connection and configuration of the Protege DIN Rail Cellular Modem is only possible with compatible controller hardware which meets the following minimum requirements.

Controller Hardware

Only controllers equipped with a USB port are capable of communicating with the cellular modem.

If it is not practical to physically check each controller for a USB port, contact ICT Technical Support with a list of the controller serial numbers.

Controller Firmware

Protege GX

Component	Version
Protege GX Software	4.3.308.3 or higher
Protege GX Controller	2.08.1310 or higher

Protege WX

Component	Version
Protege WX Controller	4.00.1241 or higher

Installation Requirements

This equipment is to be installed in accordance with:

- The product installation instructions
- UL 294 - Access Control System Units
- UL 681 - Installation and Classification of Burglar and Holdup Systems
- UL 827 - Central-Station Alarm Services
- CAN/ULC-S301, Central and Monitoring Station Burglar Alarm Systems
- CAN/ULC-S302, Installation and Classification of Burglar Alarm Systems for Financial and Commercial Premises, Safes and Vaults
- CAN/ULC-S561, Installation and Services for Fire Signal Receiving Centres and Systems
- CAN/ULC-60839-11-1, Alarm and Electronic Security Systems – Part 11-1: Electronic Access Control Systems – System and Components Requirements
- The National Electrical Code, ANSI/NFPA 70
- The Canadian Electrical Code, Part I, CSA C22.1
- The Local Authority Having Jurisdiction (AHJ)

Grounding Requirements

An effectively grounded product is one that is intentionally connected to earth ground through a ground connection or connections of sufficiently low impedance and having sufficient current-carrying capacity to prevent elevated voltages that may result in undue hazard to connected equipment or to persons.

Grounding of the Protege system is done for three basic reasons:

1. Safety
2. Component protection
3. Noise reduction

Safety Grounding

The object of safety grounding is to ensure that all metalwork is at the same ground (or earth) potential. Impedance between the Protege system and the building scheme ground must conform to the requirements of national and local industrial safety regulations or electrical codes. These will vary based on country, type of distribution system and other factors. The integrity of all ground connections should be checked periodically.

General safety dictates that all metal parts are connected to earth with separate copper wire or wires of the appropriate gauge.

Warning: All cabinet internal covers and lids/doors must be connected to the cabinet's main ground point for electrical safety and static discharge protection.

Earth Ground Connection

The DIN rail enclosure and the DIN rail modules must be grounded to a suitable single-point earth ground connection in the installation. A minimum 14AWG solid copper wire (or thicker, in accordance with local authorities) shall be used from the Protege system's earth connection points.

The DIN rail enclosure includes an earth ground single-point link connection via the metallic enclosure. This single-point link is the Protege system's earth ground. All modules that have earth ground connections and that are installed in the same enclosure shall be connected to this single point. A single-point earth ground connection avoids the creation of ground loops in the system and provides a single reference point to earth ground.

DIN Rail Ground Connections (one or more cabinets installed in the same room)

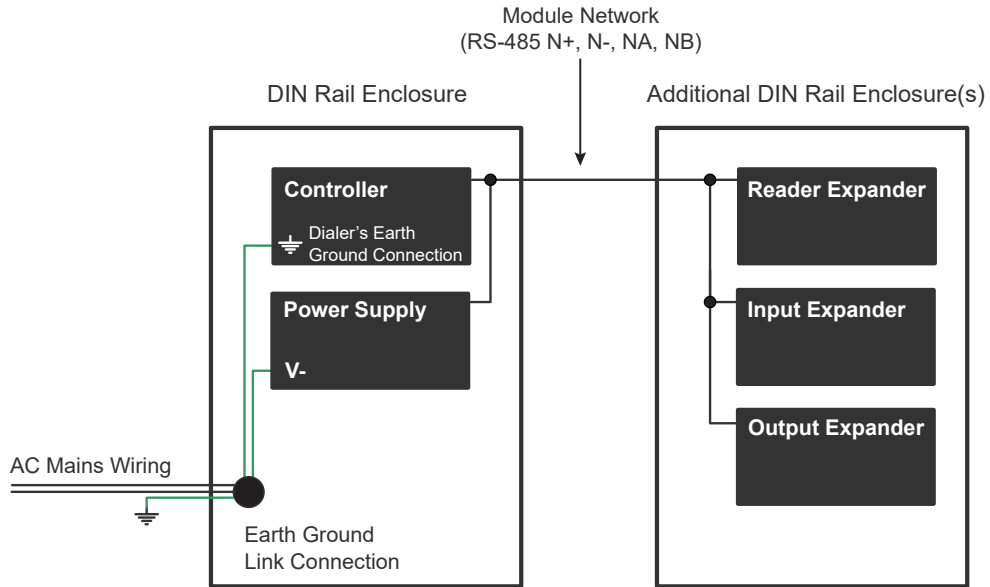

DIN Rail Ground Connections (multiple cabinets in different rooms, sectors, or buildings)

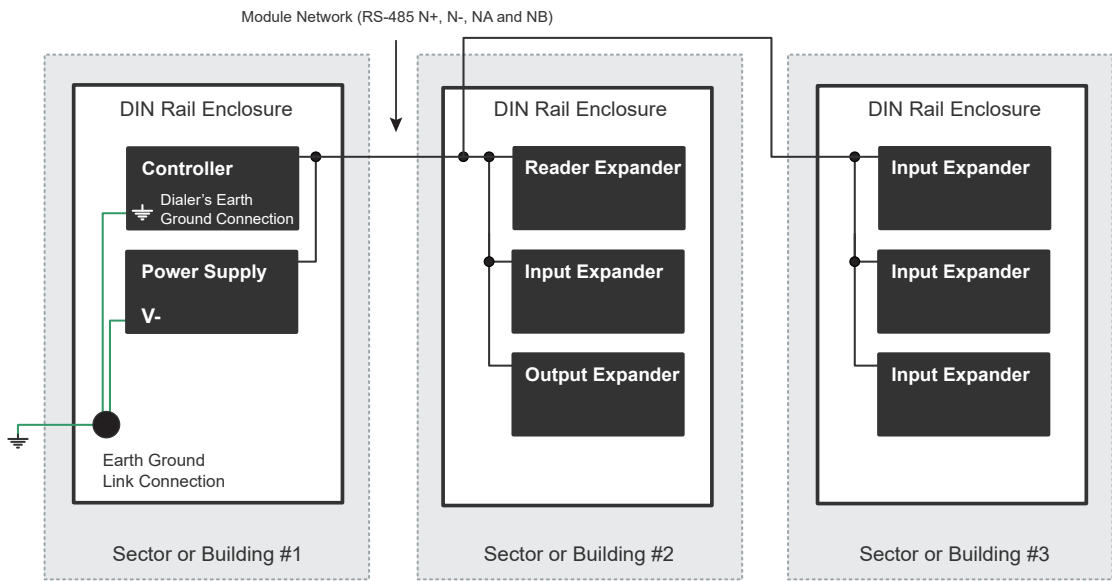

The Dialer's Earth Ground Connection applies to modem model controllers only.

Note that the DIN rail enclosure earth terminal is connected to the power supply V- terminal.

There must be only **one** single earth grounding point per system.

Mounting

Protege DIN rail modules are designed to mount on standard DIN rail, either in dedicated DIN cabinets or on generic DIN rail mounting strip.

Location

Protege DIN rail modules must be installed indoors, within the protected area. Modules must be protected by a secure cabinet with tamper detection.

We recommend installing the cabinet in a location that provides easy access for wiring. Suitable locations include electrical rooms, communication equipment rooms and accessible areas of the ceiling. Ensure that there is adequate clearance around each device and that air flow to the vents is not restricted.

Protege DIN rail modules must not be installed outdoors. Ensure that the room does not exceed or fall below the operating temperature or humidity ranges listed in the [Technical Specifications](#) for each module. Do not mount cabinets on the exterior of a vault, safe or stockroom.

Mounting a DIN Rail Module

To mount a module onto DIN rail:

1. Position the module with the labeling in the correct orientation.
2. Hook the mounting tabs (opposite the tab clip) under the edge of the DIN rail.
3. Push the DIN rail module against the mount until the tab clips over the rail.

Removal

To remove the DIN rail module from the DIN rail mount:

1. Insert a flat-blade screwdriver into the slot in the module tab clip.
2. Lever the tab outwards and rotate the unit off the DIN rail mount.

Connections

Power Requirements

Power is supplied to the cellular modem by a 12V DC power supply connected to the N+ and N- terminals.

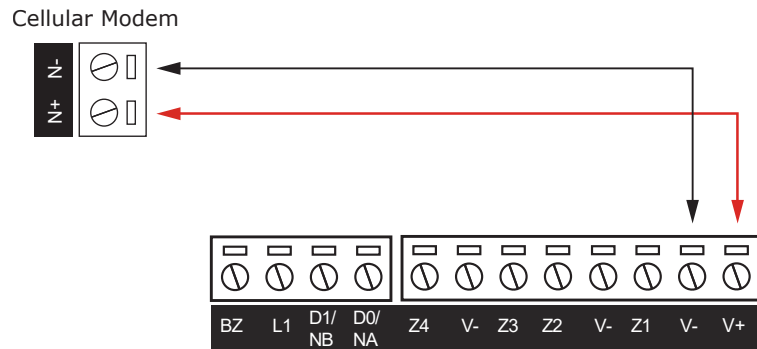

The modem is not isolated and power may be supplied by the controller, another module, or a separate 12V DC power supply. If supplied from a separate power supply the ground reference must be connected.

The SIM, antenna and USB connector cable should be installed before power is applied.

USB Connection

The cellular modem is connected to the system via USB connection to a Protege GX or Protege WX controller.

Protege controllers which do not have a physical USB port are incompatible and cannot be retrofitted.

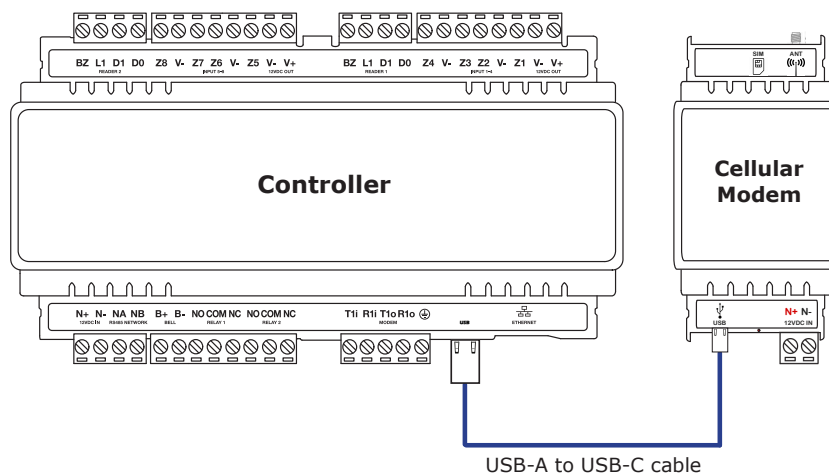

A USB-A to USB-C connector cable is supplied with the cellular modem, however any compatible cable may be used for connection. Connect the USB-A end of the cable to the USB port of the Protege controller, and the USB-C end of the cable to the USB port of the cellular modem.

Antenna Connection

The Protege DIN Rail Cellular Modem requires connection of a suitable 4G antenna.

An antenna is supplied with the cellular modem. While other antennas may be compatible only the supplied antenna is supported, and is recommended to ensure optimum performance.

Connect the antenna cable to the screw coupling of the cellular modem's SMA coaxial connector.

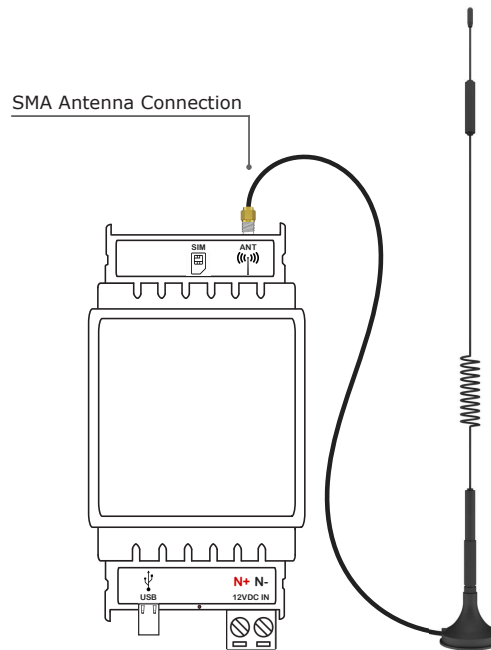

The supplied antenna has a magnetic base for mounting, and should be positioned in an area covered by the LTE signal with Cat-M1 support.

The antenna **must not** be installed inside any metal enclosure or behind any metal barriers.

SIM

A SIM card from a validated cellular network provider in the region where the Protege DIN Rail Cellular Modem is installed will be required.

For a list of validated network providers, see the Protege DIN Rail Cellular Modem Configuration Guide, available from the ICT website.

Only validated cellular networks are supported. Others may not work correctly and will not be supported by ICT.

Insert the SIM securely and fully into the cellular modem's Micro-SIM card slot, with the metal contact facing down and the notched corner inwards.

Never insert or remove the SIM while the modem is powered up.

LED Indicator

The LED indicator is lit when the correct input voltage is applied to the module and a connection between a controller and the modem is established. If connection to the controller is lost the LED indicator will be off.

Note that this indicator may take several seconds to light up after power has been applied.

The behavior of the LED indicates the state of the cellular connection.

State	Description
Off	Incorrect input voltage applied and/or no controller connection
On	Communicating with controller. Not registered on the cellular network
Blinking (1s / 1s)	Registered on the cellular network (i.e. communicating with a cell tower) This does not indicate that an internet connection has been established or that data can be sent.

Mechanical Diagram

The mechanical diagram below outlines the essential details needed to help ensure the correct installation of the DIN Rail Cellular Modem.

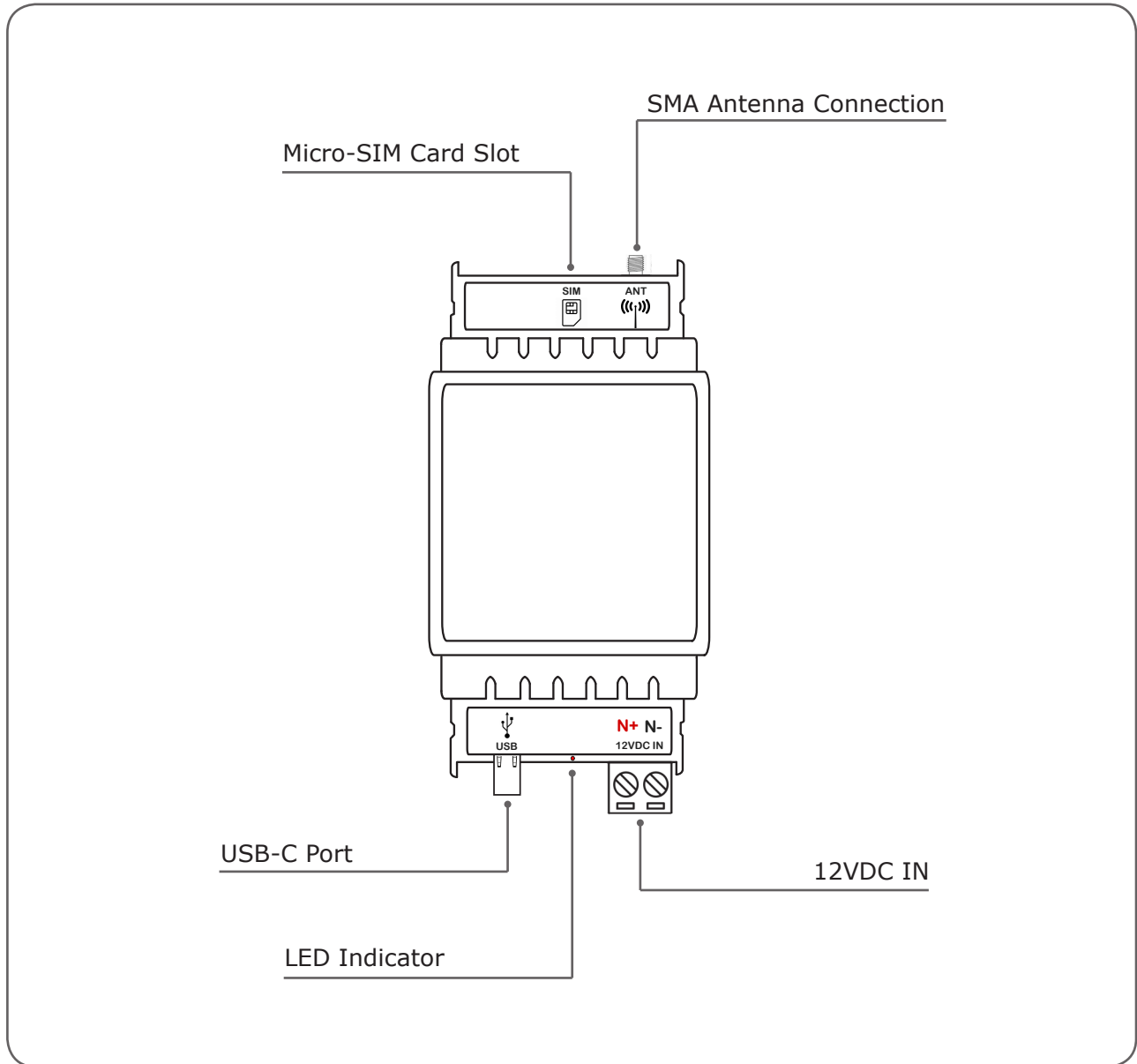

Mechanical Layout

The mechanical layout shown below outlines the essential details needed to help ensure correct installation and mounting. All measurements are shown in millimeters.

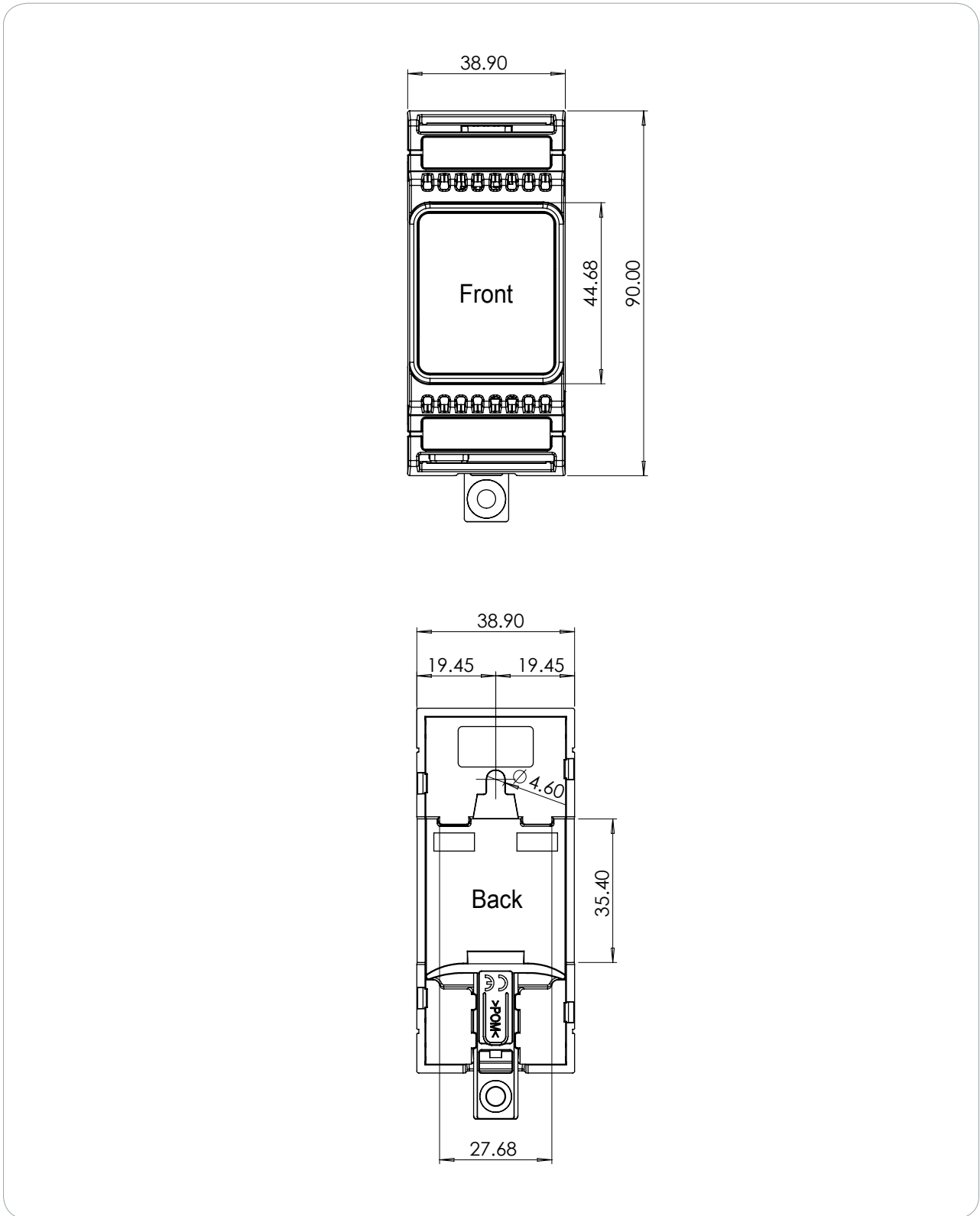

Technical Specifications

The following specifications are important and vital to the correct operation of this product. Failure to adhere to the specifications will result in any warranty or guarantee that was provided becoming null and void.

Ordering Information	
PRT-4G-USB	Protege DIN Rail Cellular Modem
Power Supply	
Operating Voltage	12V DC
Operating Current	300mA (Max)
Communications	
USB	USB-C
SIM Card Socket	Micro-SIM
Cellular Technology	4G, Dual Mode LTE-M/NB-IoT
LTE Cat-M1	Uplink up to 1 Mbps Downlink up to 588 Kbps
LTE Cat-NB2	Uplink up to 160 Kbps Downlink up to 120 Kbps
Operating Frequencies (LTE)	B1, B2, B3, B4, B5, B8, B12, B13, B18, B19, B20, B25, B26, B27, B28, B66, B71, B85
Antenna Connection	
Antenna Connector	SMA
Antenna Impedance	50ohm
Antenna Gain,VSWR	5dBi, ≤2
Antenna Frequency	4G wide band 600-2700 MHz
Polarization and Radiation Direction	Vertical, Omnidirectional
Length	320 ± 3 mm (12.6 ± .12 ")
Base Diameter	30 ± 2 mm (1.18 ± .08 ")
Mounting	Magnetic Base
Dimensions	
Dimensions (L x W x H)	39 x 90 x 60mm (1.53 x 3.54 x 2.36")
Net Weight	70g (2.5oz)
Gross Weight	200g (7.1oz)
Operating Conditions	
Operating Temperature	UL/cUL 0° to 49°C (32° to 120°F) : EU EN -10° to 55°C (14° to 131°F)
Storage Temperature	-10° to 85° C (14° to 185° F)
Humidity	0%-93% non-condensing, indoor use only (relative humidity)

It is important that the unit is installed in a dry cool location that is not affected by humidity. Do not locate the unit in air conditioning or a boiler room that can exceed the temperature or humidity specifications.

Integrated Control Technology continually strives to increase the performance of its products. As a result these specifications may change without notice. We recommend consulting our website (www.ict.co) for the latest documentation and product information.

New Zealand and Australia

Intentional Transmitter Product Statement

The R-NZ compliance label indicates that the supplier of the device asserts that it complies with all applicable standards.

R-NZ

European Standards

CE Statement

Conforms where applicable to European Union (EU) Low Voltage Directive (LVD) 2014/35/EU, Electromagnetic Compatibility (EMC) Directive 2014/30/EU, Radio Equipment Directive (RED) 2014/53/EU and RoHS Recast (RoHS2) Directive: 2011/65/EU + Amendment Directive (EU) 2015/863.

This equipment complies with the rules, of the Official Journal of the European Union, for governing the Self Declaration of the CE Marking for the European Union as specified in the above directive(s).

Lic. Number EU CE 5131A-ME910G1WW



Information on Disposal for Users of Waste Electrical & Electronic Equipment

This symbol on the product(s) and / or accompanying documents means that used electrical and electronic products should not be mixed with general household waste. For proper treatment, recovery and recycling, please take this product(s) to designated collection points where it will be accepted free of charge.

Alternatively, in some countries you may be able to return your products to your local retailer upon purchase of an equivalent new product.

Disposing of this product correctly will help save valuable resources and prevent any potential negative effects on human health and the environment, which could otherwise arise from inappropriate waste handling.

Please contact your local authority for further details of your nearest designated collection point.

Penalties may be applicable for incorrect disposal of this waste, in accordance with your national legislation.

For business users in the European Union

If you wish to discard electrical and electronic equipment, please contact your dealer or supplier for further information.

Information on Disposal in other Countries outside the European Union

This symbol is only valid in the European Union. If you wish to discard this product please contact your local authorities or dealer and ask for the correct method of disposal.

EN50131 Standards

This component meets the requirements and conditions for full compliance with EN50131 series of standards for equipment classification.

EN 50131-1:2006+A2:2017, EN 50131-3:2009, EN 50131-6:2008+A1:2014, EN 50131-10:2014, EN 50136-1:2012, EN 50136-2:2013, EN 60839-11-1:2013

Security Grade 4

Environmental Class II

Equipment Class: Fixed

Readers Environmental Class: IVA, IK07

SP1 (PSTN – voice protocol)

SP2 (PSTN – digital protocol)

SP6 (LAN – Ethernet) and DP1 (LAN – Ethernet + PSTN)

SP6 (LAN – Ethernet) and DP1 (LAN – Ethernet + USB-4G modem)

Tests EMC (operational) according to EN 55032:2015

Radiated disturbance EN 55032:2015

Power frequency magnetic field immunity tests (EN 61000-4-8)

Power Supply Type A (EN 50130-4 ed. 2)

Mains supply voltage variations (EN 50130-4 ed. 2)

Mains supply voltage dips and short interruption (EN 50130-4 ed. 2, EN 61000-4-2 ed. 2)

Electrostatic discharge (EN 50130-4 ed. 2, EN 61000-4-2 ed. 2)

Contact discharges ± 6 kV, Air discharges to ± 8 kV

Radiated electromagnetic fields (EN 50130-4 ed. 2, EN 61000-4-3 ed.3)

Conducted disturbances induced by electromagnetic fields (EN 50130-4 ed. 2, EN 61000-4-6)

Fast Transient bursts (EN 50130-4 ed. 2, EN 61000-4-4 ed.2)

To the AC mains supply lines applied disturbance signal voltage level 2 kV both polarities for 1 minute. To other supply / signal lines applied by the capacitive clamp injection method disturbance signal voltage level 1 kV for both polarities for 1 minute.

Slow high energy voltage surge (EN 50130-4 ed. 2, EN 61000-4-5 ed.2)

To comply with EN 50131-1, EN 60839-11 Security Grade 4 and AS/NZS2201.1 class 4&5 Vibration Detection for PreTamper Alarm, protection is provided by a DSC SS-102 Shockgard Seismic vibration sensor mounted within the system enclosure. Alarm output is provided by a pair of non-latching, N.C. (normally closed) relay contacts, opening for a minimum of 1 second on detection of an alarm connected in series with the 24Hr tamper input (TP) on the PSU (or any other system input designated/programmed as a 24Hr Tamper Alarm).

This relay is normally energized to give fail-safe operation in the event of a power loss. Indication of detection is provided by a LED situated on the front cover. The vibration sensor is fully protected from tampering by a N.C. micro switch operated by removal of the cover.

Enclosure EN-DIN-24 has been tested and certified to EN50131.

By design, the enclosures for all Integrated Control Technology products, EN-DIN-11, EN-DIN-12 and EN-DIN-24-ATTACK, comply with the EN 50131 standards. Tamper protection against removal of the cover as well as removal from mounting is provided by tamper switch.

Warning: Enclosures supplied by 3rd parties may not be EN50131-compliant, and should not be claimed as such.

To comply with EN 50131-1, only one battery can be connected and monitored per system. If more capacity is required, a single larger battery must be used.

UK Conformity Assessment Mark

General Product Statement

The UKCA Compliance Label indicates that the supplier of the device asserts that it complies with all applicable standards.



UL and cUL Installation Requirements

Only UL / cUL listed compatible products are intended to be connected to a UL / cUL listed control system.

UL/cUL Enclosures

All UL/cUL installations must use an enclosure (cabinet) that is listed to the relevant UL or cUL standard.

ICT offers a range of UL- and cUL-listed enclosures that are suitable for installation of Protege DIN rail products and accessories such as batteries. For our enclosure listings, see one of the following locations:

- The UL/cUL-Listed Protege Enclosures reference document, available from the ICT website.
- [UL Product iQ](#)

Central Station Signal Receiver Compatibility List

- IP Receiver via Ethernet Port: ArmorIP Internet Monitoring Receiver. Internet monitoring software and interconnected with a (DAXW/C) central station automation system software and compatible receiving equipment.
- CID Receiver via Onboard Modem: Any UL and cUL listed receiver that uses the Contact ID protocol.

Modem model only.

UL Operation Mode

UL operation mode should be enabled in Protege GX system settings. Select **Sites | Controllers | Options** and then select **Advance UL Operation** for the Protege GX system to operate in UL compliance mode.

This setting has the following effects:

- Adds a 10 second grace period following a failed poll before a module is reported as offline.
Each module sends a poll message to the controller every 250 seconds. The module will be reported as offline if no poll has been received for the duration of this poll time plus the 10 second grace period.
- Suppresses reporting of all alarms and/or reportable events to a monitoring station within the first two minutes of the controller powering up. The system will continue to send poll messages as usual.
- Reports 'Input Tamper' events as 'Input Open' events when the area that the input is assigned to is armed. If the area is disarmed an 'Input Tamper' message will be sent.
- Limits the **Dial attempts** for reporting services to a maximum of 8.

This setting must be used in conjunction with the other configuration requirements as noted in this section.

cUL Compliance Requirements

CAN/ULC-60839-11-1

- The Protege controller and reader expander module are intended to be mounted within the enclosure (refer to UL/cUL Installation Cabinet Options), installed inside the protected premise, and are CAN/ULC-60839-11-1 Listed for Class I applications only.
- Exit devices and wiring must be installed within the protected area.
- For the Protege controller and reader expander module, all RS-485 and reader terminal connections must be made using shielded grounded cable.
- All readers must be connected with shielded, grounded cable.

- A bell or visual indicator used as an arming acknowledgment signal must be listed to a cUL security, signaling or fire standard. If intended to be mounted outside, it must be rated for outdoor use.
- Fail secure locking mechanisms shall only be installed where allowed by the local authority having jurisdiction (AHJ) and shall not impair the operation of panic hardware and emergency egress.
- If fire resistance is required for door assembly, portal locking device(s) must be evaluated to ULC-S533 and CAN/ULC-S104.
- Must be installed with CAN/ULC-60839-11-1 listed portal locking device(s) for cUL installations.
- If a flexible cord is used to connect to line voltage, strain relief must be provided for the cord inside the enclosure or at the knockout.
- The power supply is not intended to be mounted on the exterior of vault, safe, or stockroom.

CAN/ULC-S304

- **Auto Arming**

Control units that support auto arming shall provide an audible signal throughout the protected area not less than 10 min prior to the auto arming taking place. The control unit shall allow authorized users to cancel the auto arming sequence and transmit such cancelation to the signal receiving center with the identification of the authorized user that canceled the action.

The following options must be enabled in the Protege system when using the Auto Arming feature. When the defer warning time is programmed to 10 minutes, the output group will be activated 10 minutes before the system performs the Auto Arming in the associated Area.

- The **Defer Output or Output Group** must be programmed. Refer to the section Areas | Outputs in the Operator Reference Manual for programming instructions.
- The **Defer Warning Time** must be programmed to not less than 10 minutes. Refer to the section Areas | Configuration in the Operator Reference Manual.
- The **Defer Automatic Arming** option must be enabled. Refer to the section Areas | Options (2) in the Operator Reference Manual.

- **Arming Signal**

A bell or visual indicator used as an arming acknowledgment signal must be listed to a cUL security, signaling or fire standard. If intended to be mounted outside, it must be rated for outdoor use.

- **Double EOL Input Configuration**

Only double EOL Input Configuration shall be used. Refer to the Inputs section of this manual and the section Inputs | Options in the Operator Reference Manual.

- **Multiplex System and Poll Time**

The Protege controller is compatible with the ArmorIP Internet Monitoring Receiver. Poll Time must be set to 40 seconds and the Grace Time must be set to 20 seconds.

In the Protege system, the reporting service must be configured to 40 seconds. The following options are required for the service selected as Report IP type:

- The **Log Polling Message** option must be enabled. Refer to the section Report IP | Options in the Operator Reference Manual.
- The **Poll Time** must be programmed to 40 seconds. Refer to the Report IP | General section in the Operator Reference Manual.

- **Central Station Signal Receiver**

The common equipment of each signal receiving center control unit shall be limited to 1000 alarm systems.

- **Number of attempts**

In the event of unsuccessful communication, a digital alarm communicator transmitter shall make a minimum of 5 and a maximum of 10 attempts. Where the maximum number of attempts to complete the sequence is reached, an indication of the failure shall be made at the premises.

In the Protege system, the reporting service selected as Contact ID must have the number of attempts programmed to 5 attempts. The **Dial Attempts** option must be programmed. Refer to the section Contact ID | Settings in the Operator Reference Manual.

If the PRT-4G-USB cellular modem is being used as the secondary reporting option in the installation, the Report IP service assigned to the cellular modem must be programmed as above.

- **Check-In Time**

DACT communication channel check-in time is not to exceed 24 hrs.

- **Trouble Input Service Test Report**

- The **Test Report Time** must be programmed. Refer to the section **Controllers | Configuration** in the Operator Reference Manual.
- The **Generate Input Restore on Test Input** option must be enabled. Refer to the section **Controller | Options** in the Operator Reference Manual.
- The **Test Report Time is Periodic** option must be enabled. Refer to the section **Controller | Options** in the Operator Reference Manual.

- **Primary Communication Channel**

The first attempt to send a status change signal shall utilize the primary communication channel.

An ethernet Report IP service must be used as the primary service. The backup service may use Contact ID over the phone line or Report IP over the cellular network if the PRT-4G-USB cellular modem is being used as the secondary communication channel.

The following options are required:

- The primary service (Report IP) must have the **Backup service** set to the secondary reporting service (Contact ID or Report IP over 4G modem). The **Service mode** must be set to 1 - Start with controller OS.
- The backup service must have **Service operates as backup** enabled. For ULC-S304 P3 applications, **Enable offline polling** must be enabled and configured so that the backup service is monitored even when it is not active.
- For Report IP services, the **Reporting protocol** must be set to Armor IP.
- Refer to the **Services** section in the Operator Reference Manual.

- **Status Change Signal**

An attempt to send a status change signal shall utilize both primary and secondary communication channels.

- **Local Annunciation if Signal Reporting Failure**

Failure of the primary communication channel or secondary communication channel shall result in a trouble signal being transmitted to the signal receiving center within 240 seconds of the detection of the fault. Failure of either communication channel shall be annunciated locally within 180 seconds of the fault.

The following options must be enabled in the Protege system:

- The **Ethernet Link Failure** trouble input must be programmed.
- The **Trouble Input Area** must be armed. Refer to the section **Trouble Inputs | Areas and Input Types** in the Operator Reference Manual.

- **Network and Domain Access**

Neither the subscriber control unit nor the signal receiving center receiver shall be susceptible to security breaches in general-purpose operating systems.

Network access policies should be set to restrict unauthorized network access and "spoofing" or "denial of service" attacks.

- **Ethernet Connections**

All ethernet network connections shall be installed within the same room as the equipment.

- **Encryption**

For active communications channel security, encryption shall be enabled at all times.

The ArmorIP-E (UDP or TCP) protocol must be used and the Encryption Type must be set to AES-256.

The following options must be enabled for the Report IP service in the Protege system.

- The **Reporting Protocol** must be set to ArmorIP (UDP) Encrypted or ArmorIP (TCP) Encrypted. The AES key must be set as specified by monitoring station.
- Refer to the section **Report IP | General** in the Operator Reference Manual.

- **Server Configuration**

Where a server is employed for control over network addressing, encryption or re-transmission, such shall be designed to remain in the "on state" at all times.

Communicators are not suitable for active communication channel security and medium or high risk applications unless such can be "online" at all times, have a minimum 128 bit encryption scheme, have encryption enabled, network and domain security implemented.

Network access policies shall be set to restrict unauthorized network access and "spoofing" or "denial of service" attacks.

- **Internet Service Provider (ISP)**

The Internet Service Provider (ISP) providing service shall meet the following requirements:

- redundant servers/systems
- back-up power
- routers with firewalls enabled and
- methods to identify and protect against "Denial of Service" attacks (i.e. via "spoofing")

- **Information Technology Equipment, Products or Components of Products**

Products or components of products, which perform communications functions only, shall comply with the requirements applicable to communications equipment as specified in CAN/CSA-C22.2 No. 62368-1, Audio/video, information and communication technology equipment - Part 1: Safety requirements. Where network interfaces, such as the following, are internal to the subscriber control unit or receiver, compliance to CAN/CSA-C22.2 No. 62368-1 is adequate. Such components include, but are not limited to:

- A) Hubs;
- B) Routers;
- C) Network interface devices;
- D) Third-party communications service providers;
- E) Digital subscriber line (DSL) modems; and
- F) Cable modems.

- **Backup Power Requirements**

Power for network equipment such as hubs, switchers, routers, servers, modems, etc., shall be backed up or powered by an uninterruptible power supply (UPS), stand-by battery or the control unit, capable of facilitating 24h standby, compliant with Clauses 16.1.2 and 16.4.1 of CAN/ULC-S304.

For communications equipment employed at the protected premises or signal receiving center and intended to facilitate packet switched communications, as defined in CAN/ULC-S304, 24h back-up power is required.

- **Compromise Attempt Events**

ArmorIP detects the reception of any invalid packet on the programmed port as a potential system **compromise attempt**. Each compromise attempt sends a notification to the receiver, and logs a Compromise Attempt event under the Live Panel Events.

The event is sent with the following details:

- **Account Code** as defined in the Serial Receiver settings
- **Event Code** 0x163
- **Group Code** as defined in the Serial Receiver settings
- **Point Code** as defined in the Serial Receiver settings

Refer to the section [Global Settings | Serial Receiver](#) in the ArmorIP Version 3 Internet Monitoring Application User Manual.

For UL and cUL installations the Central Station Receiving software must have the Contact ID details as specified, programmed for the **Compromise Attempt** event.

- **Power Supply Mains Power Connection**

If a flexible cord is used to connect to line voltage, strain relief must be provided for the cord inside the enclosure or at the knockout.

The power supply is not intended to be mounted on the exterior of vault, safe, or stockroom.

CAN/ULC-S559

Signal Reporting

The reporting services and other components shall be programmed so as to meet the requirements of CAN/ULC-S559 for either an active or passive communication system.

This includes the following provisions:

- All signals must be transmitted to the fire signal receiving center within 60 seconds.
- An active communication system shall use one or more IP reporting services. Any fault in the primary reporting service must be detected and annunciated at the fire signal receiving center within 180 seconds.
- IP reporting services may utilize either the controller's onboard ethernet or the PRT-4G-USB cellular modem. The **Reporting Protocol** must be set to ArmorIP with at least 128 bit encryption. Either UDP or TCP may be used.
- A passive communication system shall use two or more communication channels. The primary channel is a Contact ID service over the phone line, with a test signal sent at least every 6 hours. The phone dialer must make a minimum of 5 and a maximum of 10 attempts to dial the receiving center in the event of a communication failure.
- In passive systems, a DAYR7-listed cellular alarm communicator (e.g. DSC LE4010) must provide the backup channel and phone line integrity monitoring. The alarm communicator must be installed and configured in accordance with the manufacturer's instructions for CAN/ULC-S559 (commercial fire reporting) installations.

Further details and programming instructions are provided in Application Note 362: CAN/ULC-S559 Fire Reporting in Protege Systems.

Central Station Signal Receiver

The signal receiving software must be ICT ArmorIP Version 3. It must meet the following requirements:

- The **Poll Time** must be set to 40 seconds and the **Poll Grace Time** must be set to 20 seconds.
- The maximum number of signal transmitting units connected to the ArmorIP Receiver shall not exceed 10000 simultaneous connections.
- The system shall be redundant. For up to 1000 accounts, two computers must be used. Each subsequent set of 1000 accounts requires another two computers.

For instructions and hardware requirements, see the ArmorIP Version 3 Internet Monitoring Application User Manual.

Ethernet Connections

All ethernet network connections shall be installed within the same room as the equipment.

External Wiring

All wiring extending outside of the enclosure must be protected by metal conduits.

Power Supply Mains Power Connection

If a flexible cord is used to connect to line voltage, strain relief must be provided for the cord inside the enclosure or at the knockout.

The power supply is not intended to be mounted on the exterior of vault, safe, or stockroom.

Backup Power

See your power supply installation manual for backup battery power requirements for the Protege system.

Telecom equipment (switches, modems, routers) requires 24hr of standby backup power.

Arming Signal

A bell or visual indicator used as an arming acknowledgment signal must be listed to a cUL security, signaling or fire standard. If intended to be mounted outside, it must be rated for outdoor use.

Keypad Wiring

The RS-485 connection to the keypad must be wired such that the shorts and other faults on the RS-485 line connection of the keypad will not cause the controller to malfunction.

Fire Zone Inputs

Inputs 1, 2 and 3 on the controller or input expander must be connected to the Fire, Supervisory and Trouble outputs on the fire alarm control panel, as indicated in the diagrams below.

- EOL resistors must be installed at the fire alarm control panel outputs. Typical input circuits are:

Value 1	Value 2	Monitored Status
1k	1k	Open, Closed, Tamper, Short
6k8	2k2	Open, Closed, Tamper, Short
10k	10k	Open, Closed, Tamper, Short
2k2	2k2	Open, Closed, Tamper, Short
4k7	2k2	Open, Closed, Tamper, Short
4k7	4k7	Open, Closed, Tamper, Short

See the Inputs section of the controller or expander installation manual for connection diagrams.

- These inputs must have a fire area assigned, and the area must be armed. Areas used for fire reporting must not also be used for burglary.
- These inputs must be used exclusively for fire monitoring and cannot be programmed to activate the bell output.

Further details and programming instructions are provided in Application Note 362: CAN/ULC-S559 Fire Reporting in Protege Systems.

Trouble Monitoring

The following trouble inputs must have the system area assigned with the Trouble Silent input type.

- Controller Service Report Test
- Controller ContactID Reporting Failure
- Controller ReportIP Reporting Failure
- Power Supply (Analog Expander) Mains Failure

The 24 hour portion of the system area must be armed at all times.

Provided that the Power Supply Mains Failure trouble input is monitored and reported to the receiving center, it is not necessary to display a visible LED indication outside the cabinet when there is a mains power failure.

Further details and programming instructions are provided in Application Note 362: CAN/ULC-S559 Fire Reporting in Protege Systems.

Indicating Reporting Failures

Reporting failures must be indicated on the user interface for the system. There are two methods for achieving this:

- Sites with keypads can display the trouble message on the keypad.
- If the fire alarm control panel has a COM Status input, it may be connected to any available dry relay contact on the controller or output expander. When there is a reporting failure, the relay will turn on to activate the COM Status indicator on the fire alarm control panel.

Depending on how this relay is programmed, it may latch on when a reporting failure occurs. If so, a normally open monitoring reset button must be provided on controller input 4 to reset the relay output.

Further details and programming instructions are provided in Application Note 362: CAN/ULC-S559 Fire Reporting in Protege Systems.

Active/Passive Communication System Diagrams

CAN/ULC-S559 CONTROLLER ACTIVE COMMUNICATION

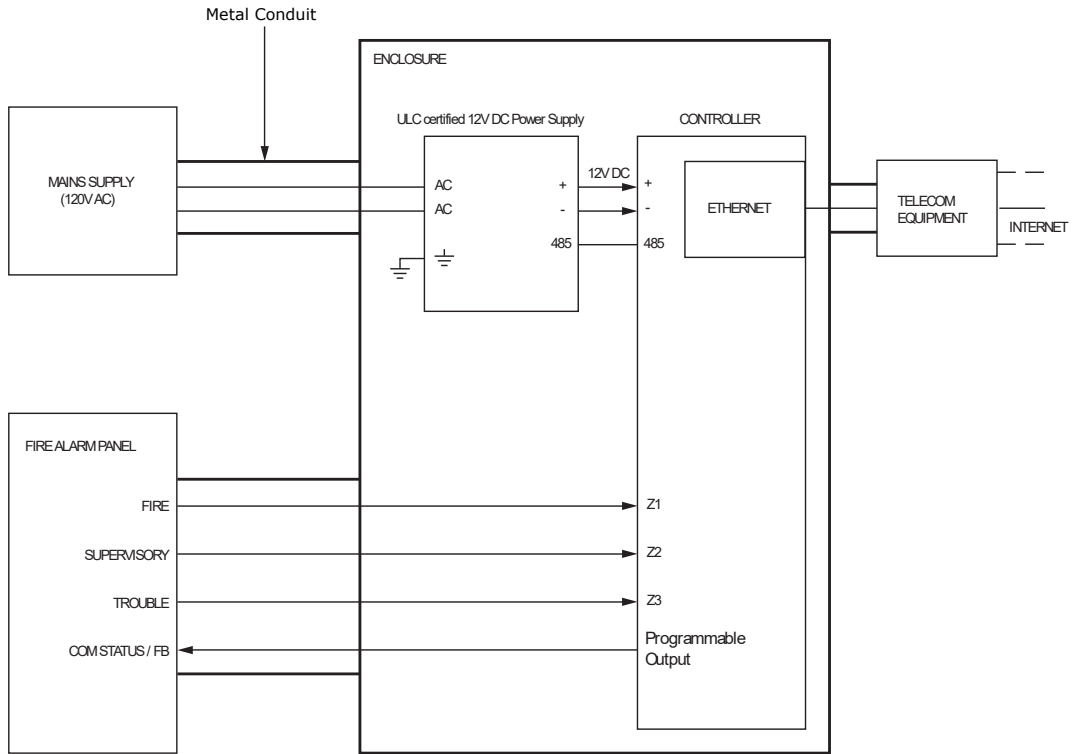

CAN/ULC-S559
 CONTROLLER
 ACTIVE COMMUNICATION: CELLULAR MODEM

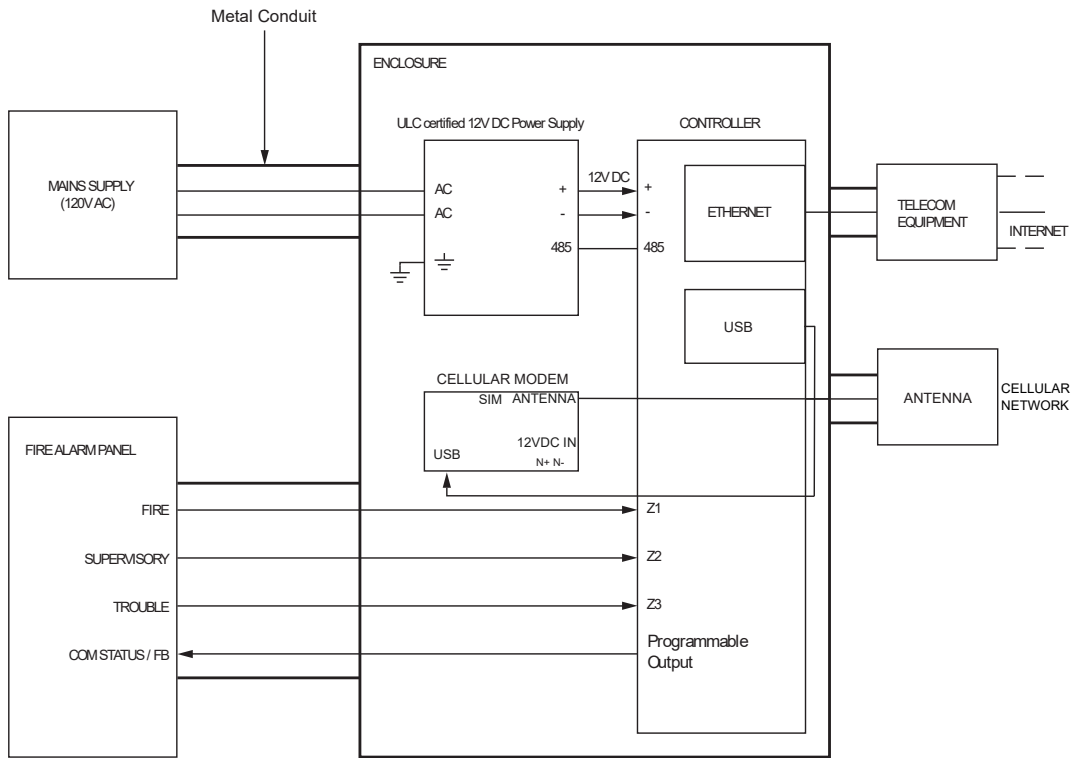

CAN/ULC-S559
 CONTROLLER
 PASSIVE COMMUNICATION: MODEM DIALER

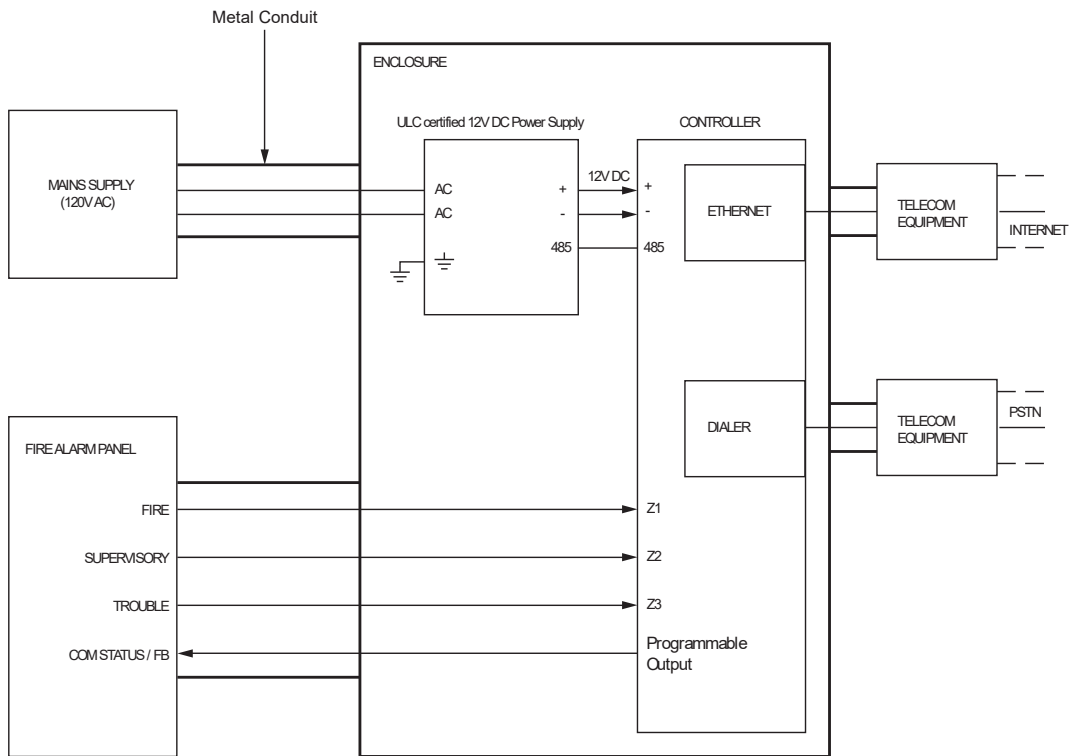

UL Compliance Requirements

UL1610

For Security Grade 4 installations, two forms of reporting are required. This can be satisfied using the onboard 2400bps modem included with the modem controller model, or through the incorporation of the PRT-4G-USB cellular modem module into the installation with the non-modem controller model.

- A local alarm sounding device, alarm housing, and control unit shall comply with the mercantile requirements in the Standard for Police Station Connected Burglar Alarm Units and Systems, UL365.
- A bell or visual indicator used as an arming acknowledgement signal must be listed to a UL security, signaling or fire standard. If intended to be mounted outside, it must be rated for outdoor use.
- Exit and entry delay must not exceed 60 seconds. To program the entry and exit delay time, refer to the section Areas | Configuration in the Operator Reference Manual.
- All ethernet network connections shall be installed within the same room as the equipment.
- Signals between the premises control unit and the receiving equipment, when not carried by wireless means, shall be protected by the following method:
 - Onboard modem telco connection must be dedicated to the Protege controller.

Modem model only.

- Ethernet connection to the Internet Service Provider (ISP) with a fixed IP Address must be dedicated to the Protege controller.
- To comply with the dual signal line transmission system requirement, both transmission lines (onboard modem and IP reporting) must be enabled. Signals shall be sent simultaneously to both the primary communications channel and the Backup Service.

The Report IP and Contact ID services must be programmed and enabled within the Protege system. The following options are required:

- The **Contact ID Reporting Service** must be enabled and the **Service Mode** must be configured to start with the operating system.
- Refer to the section Contact ID in the Operator Reference Manual.
- The **Report IP Service** must be enabled as the primary communication channel, the **Service Mode** must be configured to start with the operating system, and the **Reporting Protocol** must be set to ArmorIP.
- Refer to the section Report IP in the Operator Reference Manual.
- When more than one means of signal transmission is used, loss of communication with the receiving system shall be annunciated at the receiver within 200 seconds. If a fault is detected on any of the signal transmission means, at least one of the signal transmission channels shall send a signal to the central-station to report the fault within 200 seconds.

The Report IP and Contact ID services must be programmed and enabled within the Protege system.

The Protege controller is compatible with the ArmorIP Internet Monitoring Receiver. Poll Time must be set to 40 seconds and the Grace Time must be set to 20 seconds.

In the Protege system, the reporting service must be configured to 40 seconds. The following options are required for the service selected as Report IP type:

- The **Poll Time** must be programmed to 40 seconds. Refer to the Report IP | General section in the Operator Reference Manual
- The **Contact ID Reporting Service** must be enabled and the **Service Mode** must be configured to start with the operating system.
- Refer to the section Contact ID in the Operator Reference Manual
- The **Report IP Service** must be enabled as the primary communication channel, the **Service Mode** must be configured to start with the operating system, and the **Reporting Protocol** must be set to ArmorIP.
- Refer to the section Report IP in the Operator Reference Manual.
- The **Trouble Input Area** must be armed in 24h mode. Refer to the section Trouble Inputs | Areas and Input Types in the Operator Reference Manual.

In the event of unsuccessful communication, a digital alarm communicator transmitter shall make a minimum of 5 and a maximum of 10 attempts. Where the maximum number of attempts to complete the sequence is reached, an indication of the failure shall be made at the premises.

In the Protege system, the reporting service selected as Contact ID must have the number of attempts programmed to 5 attempts. The following options are required:

- The **Dial Attempts** option must be programmed. Refer to the section Contact ID | Settings in the Operator Reference Manual.
- DACT communication channel check-in time is not to exceed 24 hrs.
- Trouble Zone Service Test Report
 - The **Test Report Time** must be programmed. Refer to the section Controllers | Configuration in the Operator Reference Manual.
 - The **Generate Input Restore on Test Input** option must be enabled. Refer to the section Controller | Options in the Operator Reference Manual.
 - The **Test Report Time is Periodic** option must be enabled. Refer to the section Controller | Options in the Operator Reference Manual.
 - ArmorIP detects the reception of any invalid packet on the programmed port as a potential system **compromise attempt**. Each compromise attempt sends a notification to the receiver, and logs a Compromise Attempt event under the Live Panel Events.

The event is sent with the following details:

- **Account Code** as defined in the Serial Receiver settings
- **Event Code** 0x163
- **Group Code** as defined in the Serial Receiver settings
- **Point Code** as defined in the Serial Receiver settings

Refer to the section Global Settings | Serial Receiver in the ArmorIP Version 3 Internet Monitoring Application User Manual.

For UL and cUL installations the Central Station Receiving software must have the Contact ID details as specified, programmed for the **Compromise Attempt** event.

- If a flexible cord is used to connect to line voltage, strain relief must be provided for the cord inside the enclosure or at the knockout.
- The power supply is not intended to be mounted on the exterior of vault, safe, or stockroom.

UL294

- The Protege controller and reader expander module are intended to be mounted within the enclosure (refer to UL/cUL Installation Cabinet Options), installed inside the protected premise, and are UL 294 Listed for Attack Class I applications only.
- Exit devices and wiring must be installed within the protected area.
- For the Protege controller and reader expander module, all RS485 and reader terminal connections must be made using shielded grounded cable.
- All readers must be connected with shielded, grounded cable.
- A bell or visual indicator used as an arming acknowledgment signal must be listed to a UL security, signaling or fire standard. If intended to be mounted outside, it must be rated for outdoor use.
- Fail secure locking mechanism shall only be installed where allowed by the local authority having jurisdiction (AHJ) and shall not impair the operation of panic hardware and emergency egress.
- If fire resistance is required for door assembly, portal locking device(s) must be evaluated to UL10B or UL10C.
- Must be installed with UL 1034 listed electronic locks for UL installations.
- AC power on shall be indicated by an external panel mount LED (Lumex SSI-LXH312GD-150) and fitted into a dedicated 4mm hole in the cabinet to provide external visibility. This shall be wired between 12V and a PGM output that is programmed to follow the AC trouble input as shown below:

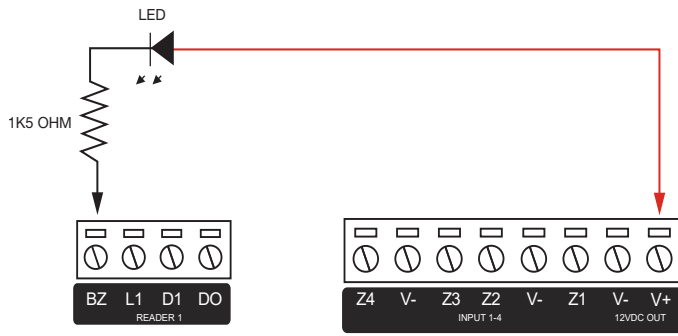

- If a flexible cord is used to connect to line voltage, strain relief must be provided for the cord inside the enclosure or at the knockout.
- The power supply is not intended to be mounted on the exterior of vault, safe, or stockroom.

FCC Compliance Statements

FCC Rules and Regulations CFR 47, Part 15, Subpart C

This equipment complies with the limits for a Class B digital device, pursuant to Part 15 of the FCC rules.

Operation is subject to the following two conditions:

- This device may not cause harmful interference.
- This device must accept any interference received, including interference that may cause undesired operation.

NOTE: THE GRANTEE IS NOT RESPONSIBLE FOR ANY CHANGES OR MODIFICATIONS NOT EXPRESSLY APPROVED BY THE PARTY RESPONSIBLE FOR COMPLIANCE. SUCH MODIFICATIONS COULD VOID THE USER'S AUTHORITY TO OPERATE THE EQUIPMENT.

FCC Part 22/24, FCC ID RI7ME910G1WW

Industry Canada Statement

ICES-003

This class B digital apparatus complies with Canadian ICES-003.

Cet appareil numérique de classe B est conforme à la norme canadienne ICES-003.

CAN ICES-3 (B) / NMB-3 (B) (ISED only) / (ISDE seulement)

Cellular Modem REGISTRATION NUMBER

IC: R17ME910G1WW

Cellular Modem NUMÉRO D'ENREGISTREMENT

IC: R17ME910G1WW

Disclaimer and Warranty

Disclaimer: Whilst every effort has been made to ensure accuracy in the representation of this product, neither Integrated Control Technology Ltd nor its employees shall be liable under any circumstances to any party in respect of decisions or actions they may make as a result of using this information. In accordance with the ICT policy of enhanced development, design and specifications are subject to change without notice.

For warranty information, see our [Standard Product Warranty](#).

Designers & manufacturers of integrated electronic access control, security and automation products.
Designed & manufactured by Integrated Control Technology Ltd.
Copyright © Integrated Control Technology Limited 2003-2026. All rights reserved.

Disclaimer: Whilst every effort has been made to ensure accuracy in the representation of this product, neither Integrated Control Technology Ltd nor its employees shall be liable under any circumstances to any party in respect of decisions or actions they may make as a result of using this information. In accordance with the ICT policy of enhanced development, design and specifications are subject to change without notice.