



PRT-MNR2-DIN

Protege Module Network Repeater

Installation Manual



The specifications and descriptions of products and services contained in this document were correct at the time of printing. Integrated Control Technology Limited reserves the right to change specifications or withdraw products without notice. No part of this document may be reproduced, photocopied, or transmitted in any form or by any means (electronic or mechanical), for any purpose, without the express written permission of Integrated Control Technology Limited. Designed and manufactured by Integrated Control Technology Limited, Protege® and the Protege® Logo are registered trademarks of Integrated Control Technology Limited. All other brand or product names are trademarks or registered trademarks of their respective holders.

Copyright © Integrated Control Technology Limited 2003-2026. All rights reserved.

Last Published: 08-Jan-26 1:08 PM

Contents

Introduction	5
Installation Requirements	6
Grounding Requirements	7
Safety Grounding	7
Earth Ground Connection	7
Mounting	9
Removal	9
Power Requirements	10
Powering the Network Repeater	10
Powering the Spurs	11
Encrypted Module Network	12
Module Wiring	13
End of Line (EOL) Resistors	13
Ethernet 10/100 Network Connection	14
Network Expansion	15
Network Repeater Configuration	17
Logging in for the First Time	17
Configuration	17
Device Information	19
User Management	19
Defaulting the Module	20
LED Indicators	21
Power Indicator	21
Status Indicator	21
Fault Indicator	21
Ethernet Indicator	21
COM Indicators	22
Mechanical Diagram	23
Mechanical Layout	24
Technical Specifications	25
New Zealand and Australia	26
ASIAL Class 5	26
European Standards	27
UK Conformity Assessment Mark	29

FCC Compliance Statements	30
Industry Canada Statement	31
Disclaimer and Warranty	32

Introduction

The Protege Module Network Repeater is designed to extend the network capabilities of the Protege system, an advanced technology security product providing seamless and powerful integration of access control, intruder detection and building automation.

The network repeater is added to the system via RS-485 or ethernet and provides optical isolation between up to three branches of the module network, easing power requirements.

The current features of the network repeater include:

- 3 isolated RS-485 connections
- 10/100 ethernet
- RS-485 or ethernet network expansion
- Secure encrypted RS-485 module communications

Installation Requirements

This equipment is to be installed in accordance with:

- The product installation instructions
- AS/NZS 2201.1 Intruder Alarm Systems
- The Local Authority Having Jurisdiction (AHJ)

Grounding Requirements

An effectively grounded product is one that is intentionally connected to earth ground through a ground connection or connections of sufficiently low impedance and having sufficient current-carrying capacity to prevent elevated voltages that may result in undue hazard to connected equipment or to persons.

Grounding of the Protege system is done for three basic reasons:

1. Safety
2. Component protection
3. Noise reduction

Safety Grounding

The object of safety grounding is to ensure that all metalwork is at the same ground (or earth) potential. Impedance between the Protege system and the building scheme ground must conform to the requirements of national and local industrial safety regulations or electrical codes. These will vary based on country, type of distribution system and other factors. The integrity of all ground connections should be checked periodically.

General safety dictates that all metal parts are connected to earth with separate copper wire or wires of the appropriate gauge.

Warning: All cabinet internal covers and lids/doors must be connected to the cabinet's main ground point for electrical safety and static discharge protection.

Earth Ground Connection

The DIN rail enclosure and the DIN rail modules must be grounded to a suitable single-point earth ground connection in the installation. A minimum 14AWG solid copper wire (or thicker, in accordance with local authorities) shall be used from the Protege system's earth connection points.

The DIN rail enclosure includes an earth ground single-point link connection via the metallic enclosure. This single-point link is the Protege system's earth ground. All modules that have earth ground connections and that are installed in the same enclosure shall be connected to this single point. A single-point earth ground connection avoids the creation of ground loops in the system and provides a single reference point to earth ground.

DIN Rail Ground Connections (one or more cabinets installed in the same room)

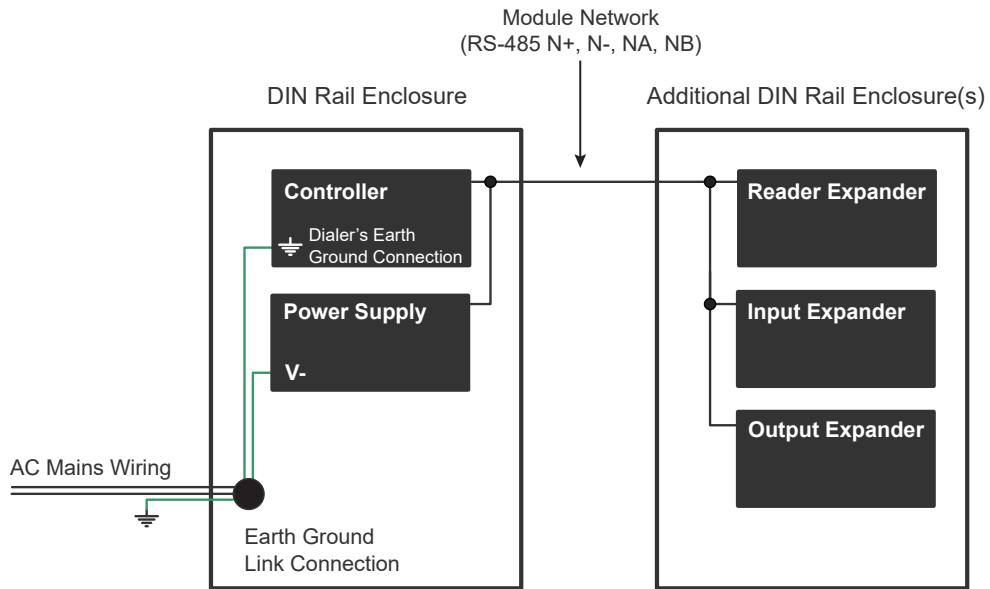

DIN Rail Ground Connections (multiple cabinets in different rooms, sectors, or buildings)

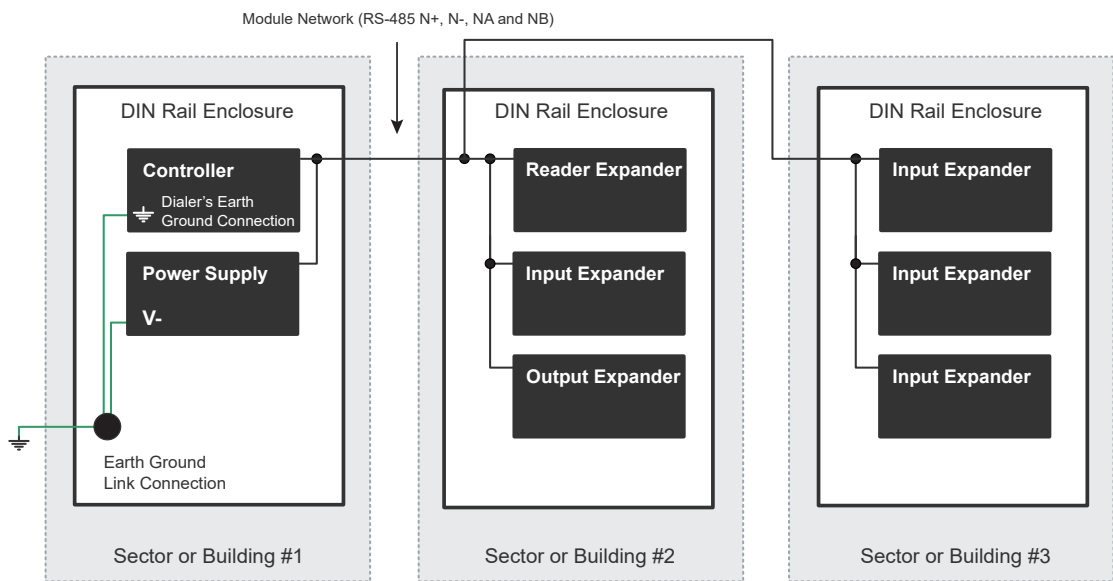

The Dialer's Earth Ground Connection applies to modem model controllers only.

Note that the DIN rail enclosure earth terminal is connected to the power supply V- terminal.

There must be only **one** single earth grounding point per system.

Mounting

Protege DIN rail modules are designed to mount on standard DIN rail, either in dedicated DIN cabinets or on generic DIN rail mounting strip.

Location

Protege DIN rail modules must be installed indoors, within the protected area. Modules must be protected by a secure cabinet with tamper detection.

We recommend installing the cabinet in a location that provides easy access for wiring. Suitable locations include electrical rooms, communication equipment rooms and accessible areas of the ceiling. Ensure that there is adequate clearance around each device and that air flow to the vents is not restricted.

Protege DIN rail modules must not be installed outdoors. Ensure that the room does not exceed or fall below the operating temperature or humidity ranges listed in the [Technical Specifications](#) for each module. Do not mount cabinets on the exterior of a vault, safe or stockroom.

Mounting a DIN Rail Module

To mount a module onto DIN rail:

1. Position the module with the labeling in the correct orientation.
2. Hook the mounting tabs (opposite the tab clip) under the edge of the DIN rail.
3. Push the DIN rail module against the mount until the tab clips over the rail.

Removal

To remove the DIN rail module from the DIN rail mount:

1. Insert a flat-blade screwdriver into the slot in the module tab clip.
2. Lever the tab outwards and rotate the unit off the DIN rail mount.

Power Requirements

Powering the Network Repeater

For devices using hardware revision 010, COM1 is only used for supplying power to the network repeater when connected via ethernet.

Power to the network repeater is supplied by the N+ and N- terminals on the COM1 port and is also used for the onboard electronics and the ethernet connection.

When the network repeater is connected to the module network via ethernet, module power is supplied to the COM1 port via a 12VDC independent battery backed power supply unit capable of supplying the required voltage.

This same power supply can be used to supply the COM1 module network spur as well, as long as the maximum load of the power supply is not exceeded.

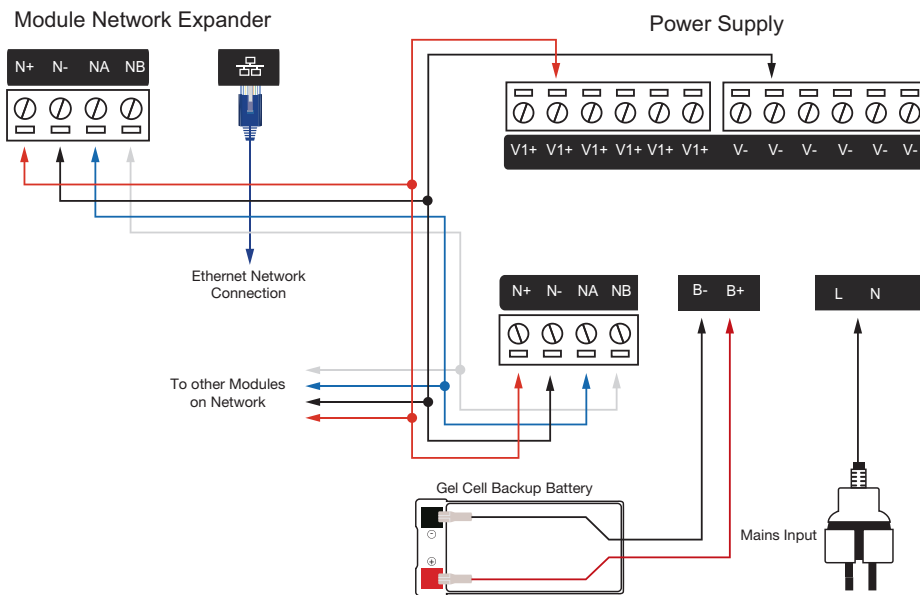

If the network repeater is inserted into an existing section of the module network the auxiliary outputs of a controller can be used to supply other equipment.

Note that there is no onboard regulation or isolation for these outputs; they are a fused feed-through from the N+ N- input terminals.

When using these outputs to supply other devices, be sure not to exceed the rating of the internal fuses as outlined in the Technical Specifications (see page 25).

Power can also be supplied from an additional 12VDC battery backed power supply.

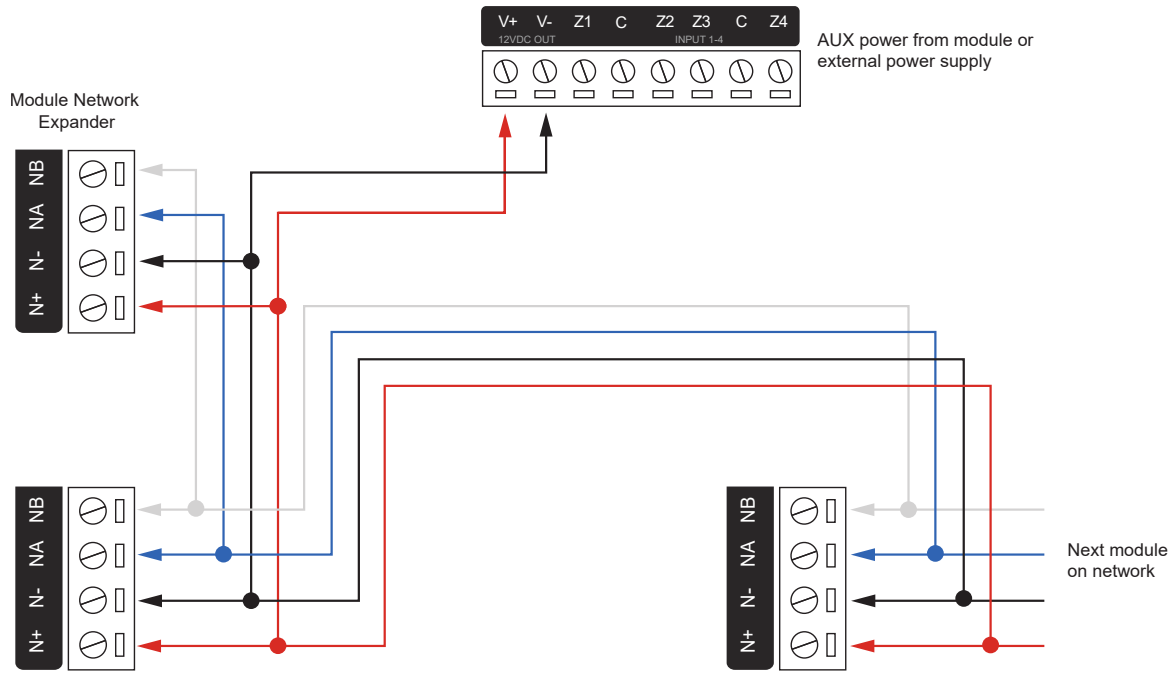

Powering the Spurs

For devices using hardware revision 010, you can only use COM2 and COM3 to create module network spurs when the network repeater is connected via ethernet. In this scenario, COM1 is only used for supplying power to the network repeater.

The COM2 and COM3 ports are powered separately and are optically isolated from each other. An independent battery backed power supply unit is required for each spur.

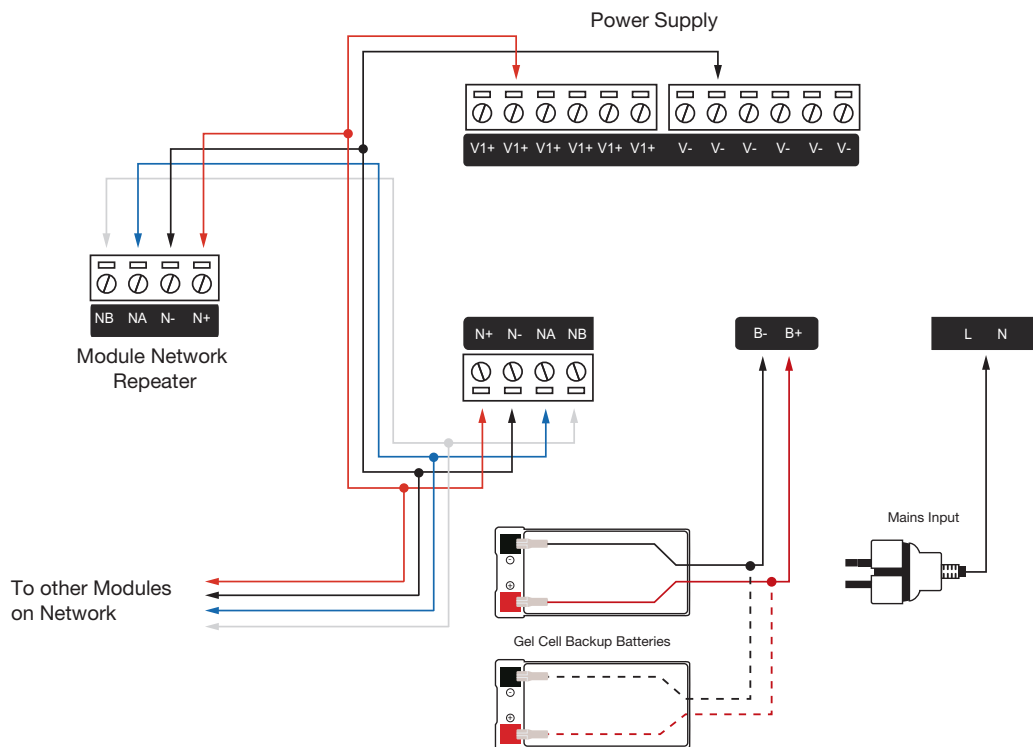

Encrypted Module Network

For devices using hardware revision 010, you can only use COM2 and COM3 to create module network spurs when the network repeater is connected via ethernet. In this scenario, COM1 is only used for supplying power to the network repeater.

The network repeater incorporates encrypted RS-485 communications technology. The isolated communications interface offers full galvanic isolation to prevent ground loop noise and cross-phase ground differential between network devices on the three RS-485 ports.

Standard Communication Connection:

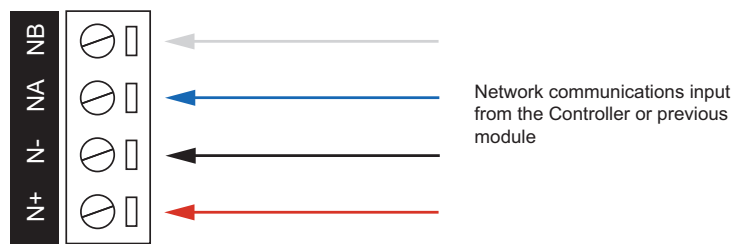

It is important that the N+ network communications power be 12VDC supplied from an independent battery backed power supply unit capable of supplying the required voltage to all devices on the RS-485 network.

Always connect the NA and NB terminals of the network repeater to the NA and NB terminals of the communication network. The N+ and N- must go to a 12V power supply source as shown in the following diagram, and connected at **one** +12V power source only.

Network Power Supplied By Network Module:

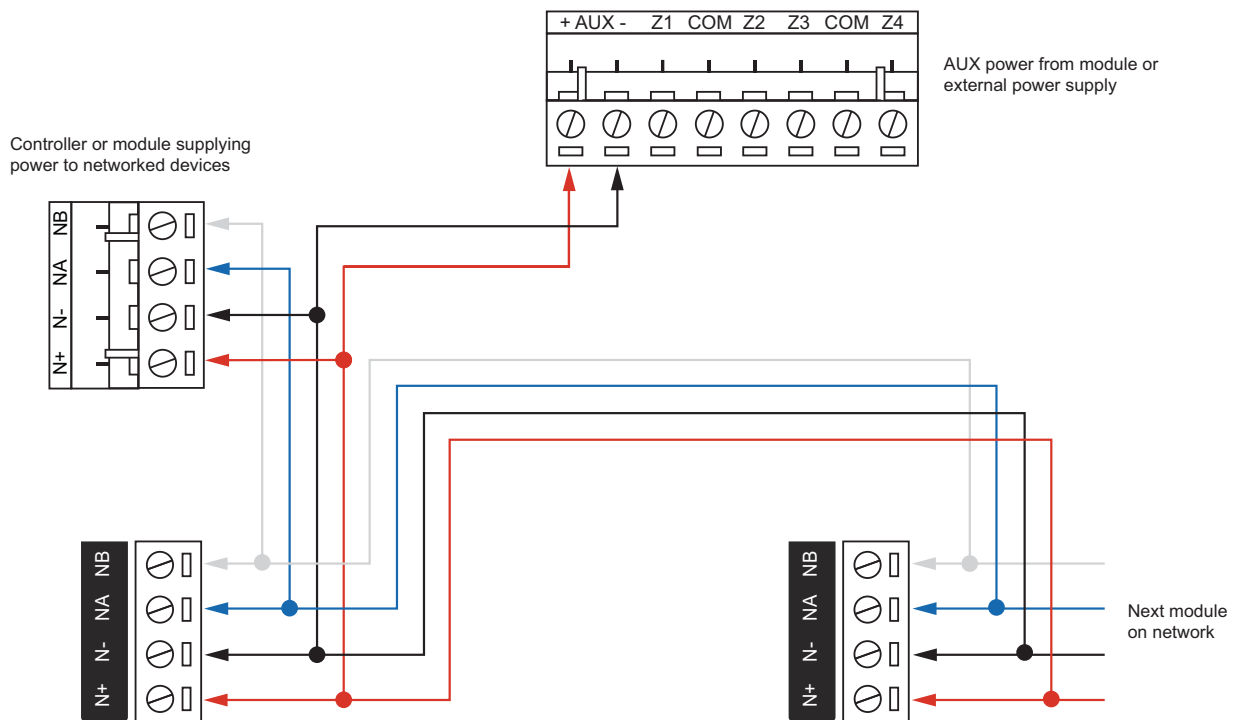

Module Wiring

The recommended module network wiring specifications are:

- Minimum 24AWG (0.51mm) shielded twisted pair with characteristic impedance of 120Ω
- Maximum total length of cable is 900m (3000ft)
- CAT5e / CAT6 are also supported for data transmission when using ground in the same cable (to a maximum length of 100m (328ft))

Warning: Unused wires in the cable must not be used to carry power to other devices.

End of Line (EOL) Resistors

End-of-line resistors prevent signal reflections at the ends of the RS-485 network bus, improving signal strength and reducing data corruption.

You must insert a **120Ω resistor** between the NA and NB terminals of the **first** and **last** modules on the RS-485 network. These are the modules physically located at the ends of the RS-485 network cabling.

First Module on RS-485 Network

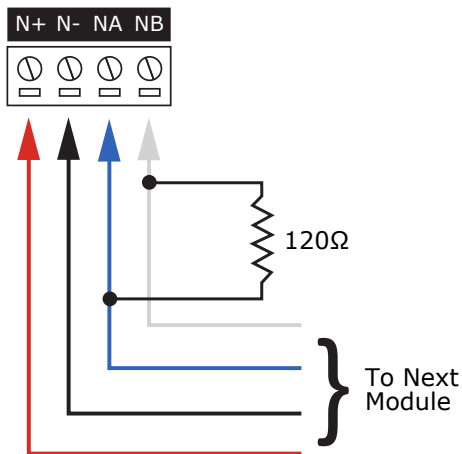

Last Module on RS-485 Network

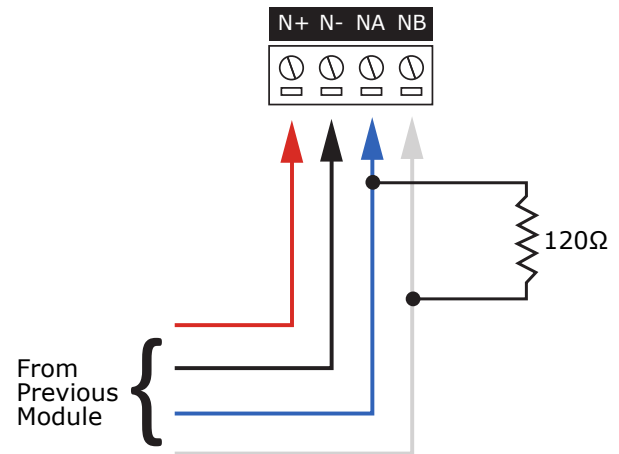

The PRT-MNR2-DIN Module Network Repeater would typically be the first module on the RS-485 module network, but this may not always be the case.

Ethernet 10/100 Network Connection

The network repeater can communicate with the controller via a 10/100 ethernet connection using the encrypted UDP protocol, or via the RS-485 module network using the COM1 port.

Ethernet communication is not enabled by default and is configured through the web interface (see page 17).

When installing an ethernet connection the module should be interfaced using a standard segment (<100m in length) and should be connected to a suitable ethernet hub or switch:

Installing the module on an active network requires knowledge of the configuration and structure for the network. Always consult the network or system administrator and ask them to provide you with a fixed IP address that can be assigned to the module.

Ethernet 10/100 Switch Hub Connection:

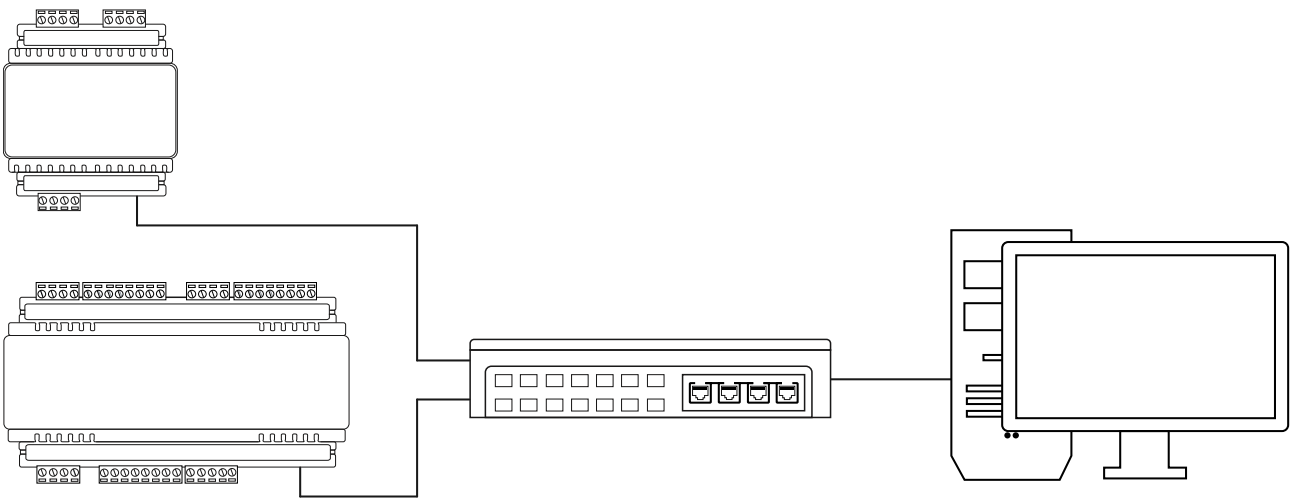

Temporary direct connections can be used for onsite programming by using a standard ethernet cable.

Ethernet 10/100 Direct Connection:

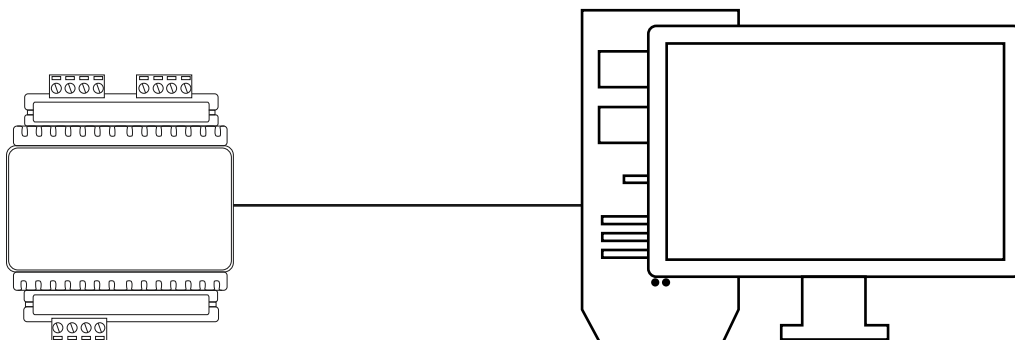

Network Expansion

No more than 10 network repeaters can be used in a single module network in any configuration (UDP or RS-485). Using the network repeater, the module network should not be extended more than double the standard run length of 900m / 3000ft.

You can connect the network repeaters directly in series (daisy chain) but you must not exceed 10 modules in total and not exceed double the standard module network run length of 900m / 3000ft.

The network repeater provides the ideal solution for:

- Module networks that run between two buildings.
- Resolving issues with networks that are experiencing connectivity / communication issues caused by ground loops or long distance runs.
- Extending the LAN using ethernet to remove the need to run expensive cabling over long networks.
- Creating isolated RS-485 networks for keypads or devices located outside or in publicly accessible areas.
- Situations where there are physical locations where wiring is difficult.
- Extending the RS-485 module network. While the maximum length of the RS-485 module network is 900m (3000ft), the network repeater enables you to extend it beyond this by repeating the signals sent.
- Replacing existing systems that use spur wiring.

The ethernet solution enables the network repeater to communicate via UDP through a switch or router.

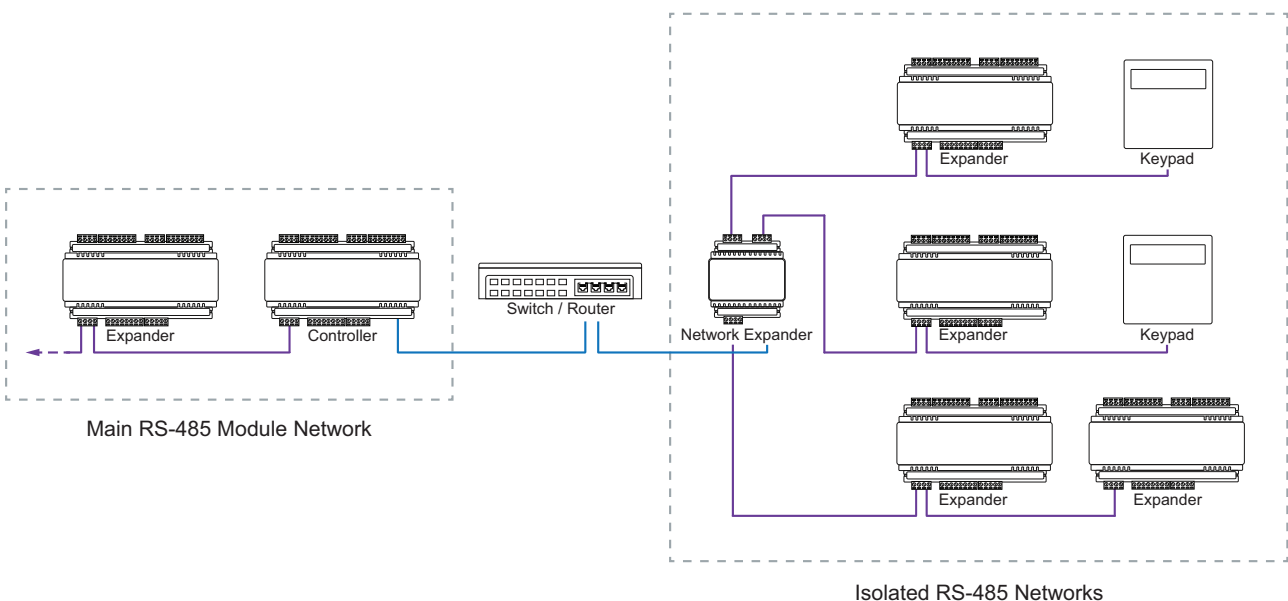

With RS-485 you can insert the network repeater anywhere within the LAN to strengthen communications or resolve network issues.

Network Expansion using RS-485:

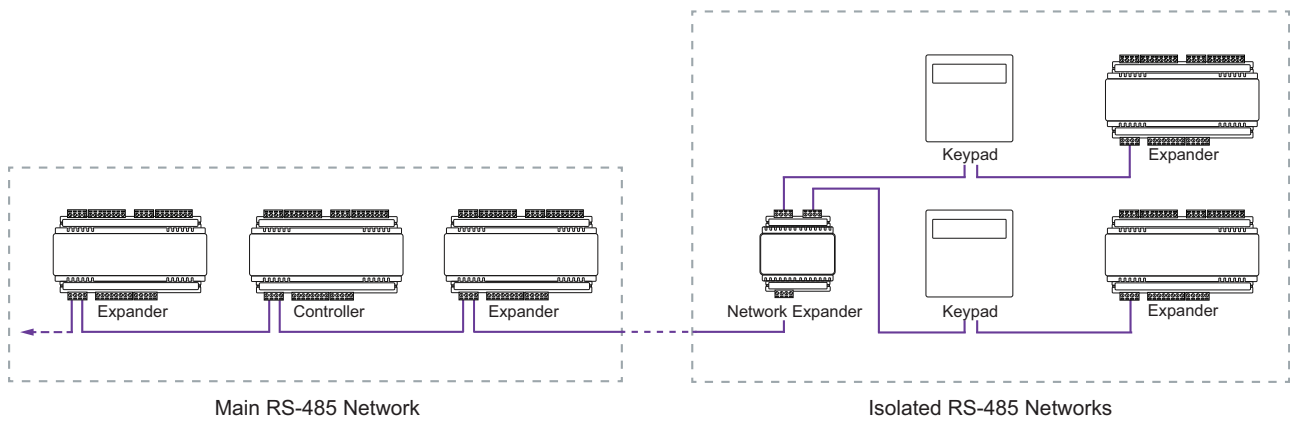

Network Repeater Configuration

Configuration of the network repeater is carried out using the built-in web interface. To access the web interface, open an internet browser and type the IP address of the network repeater into the address bar.

The default IP address is **192.168.1.3**.

If the current IP address is not known it can be temporarily set to **192.168.111.222** by linking the N+ N- NA and NB connections between the COM1 and COM2 ports, then cycling power to the device.

Defaulting the IP Address:

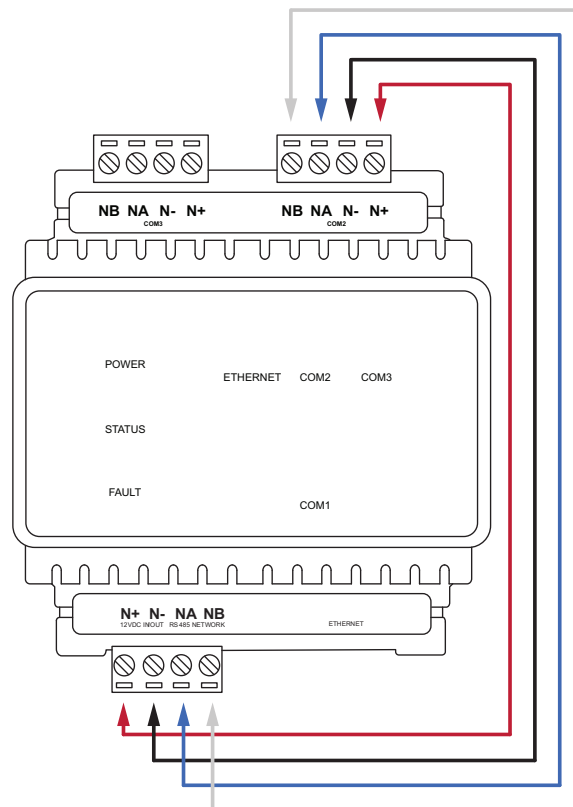

When attempting to view the web interface from a network that uses a proxy server, ensure the browser connection options are configured to recognize local addresses.

Logging in for the First Time

1. Open a web browser and enter the default IP address of **192.168.1.3**
2. Enter the default operator login of admin with the password admin.

For security reasons, this password should be changed before deployment.

3. Click **Sign In**.

Configuration

Programming the IP address, subnet mask, and default gateway requires knowledge of the network and subnet that the system is connected to. You should always consult the network or system administrator before programming these values.

IP Config

The module can be configured to use either a static or dynamic IP address.

- **Physical Address:** The MAC address of the module.
- **Enable DHCP:** When enabled, the module will use DHCP to dynamically allocate an IP address instead of using a static IP address. To use this there must be a DHCP server on the network you are attempting to connect to.
- **IP Address:** The module must be programmed with a valid TCP/IP address to allow it to connect to the system controller. By default the IP address is set to 192.168.1.3.
- **Subnet Mask:** Used in conjunction with the IP address, a netmask must be configured to allow access to the appropriate node on the subnet. By default this is set to 255.255.255.0.
- **Gateway:** Used in conjunction with the IP address, the gateway can be configured to allow access to a router for external communications beyond the subnet to which the module is connected. By default this is set to 192.168.1.1.
- **DNS Server:** Defines the IP address of the DNS Server if one is used.

Physical Config

You can configure each of the COM ports for failsafe biasing if a controller is not connected. Failsafe biasing is not required for ports that have a controller connected as controllers are already equipped with this feature.

If the **Repeater Mode** (below) is set to UDP Mode, COM biasing must be enabled on **all** COM ports.

For devices using hardware revision 010, configurable biasing is not available.

- **COM Biasing:** When selected, failsafe biasing is enabled for the specific port.

Repeater Config

The module needs to know which controller it should communicate with and the mode to be used.

- **Repeater Mode:** Defines the method that the module uses to communicate with the controller. By default this is set to RS-485.
 - **RS-485 mode:** When in RS-485 mode, all module network packets received on COM2 and COM3 are forwarded to COM1. All packets received on COM1 are forwarded to COM2 and COM3.
 - **UDP mode:** When UDP is selected, all of the RS-485 ports can be used to connect to isolated module networks*. All ICT module network packets received on the RS-485 connections will be forwarded to the controller over UDP to the IP and port specified in the configuration.

*For devices using hardware revision 010, only COM2 and COM3 can be used

In this mode, COM biasing must be enabled on **all** COM ports if available.

- **UDP IP/Host:** The IP address or host name of the controller.
- **UDP Resolved IP/Host:** If a dynamic connection is used you can confirm the controller's IP address by viewing this field.
- **UDP Port:** The UDP port defines the port the expander uses to connect to the controller. This must match the controller.

When connecting to a controller that is running firmware version 2.08.886 or higher, module comms and TLCD comms ports (9450 & 9460) over ethernet are disabled by default. You will need to enable these ports for the module to communicate with the controller, by adding commands to the controller programming.

- To enable Module Comms UDP/TCP (9450) add the commands:
EnableModuleUDP = true
EnableModuleTCP = true
- To enable Touch Screen Comms UDP (9460) add the command:
EnableTLCDCommsUDP = true

Restart Device

Use this option to restart the module.

Device Information

The device information page displays the serial number, hardware revision and firmware versions of the network repeater, as well as statistics such as the status of the COM ports and the bytes that have been successfully repeated since the last power cycle.

This page is also used to upgrade the module's firmware by putting the device into boot mode then transferring a firmware file to the device by TFTP.

User Management

The module comes with two default users:

Username	Password
admin	admin
user	user

When logged in as admin, the operator can access all pages and change any parameter. In comparison, the user account permits access to the main (home) and device information pages.

To edit a user, click on the appropriate checkbox, then click **Edit**. This opens a new page where the user settings can be changed.

For security reasons, we recommend you change the password of the admin user before deployment.

Defaulting the Module

If you lose access to your network repeater or need to reset all of the settings, you can default the module.

This function is supported in firmware versions 1.0.27 and higher.

To default the module link the N+ N- NA and NB connections between **all three COM ports**, then cycle power to the device.

Defaulting the Module:

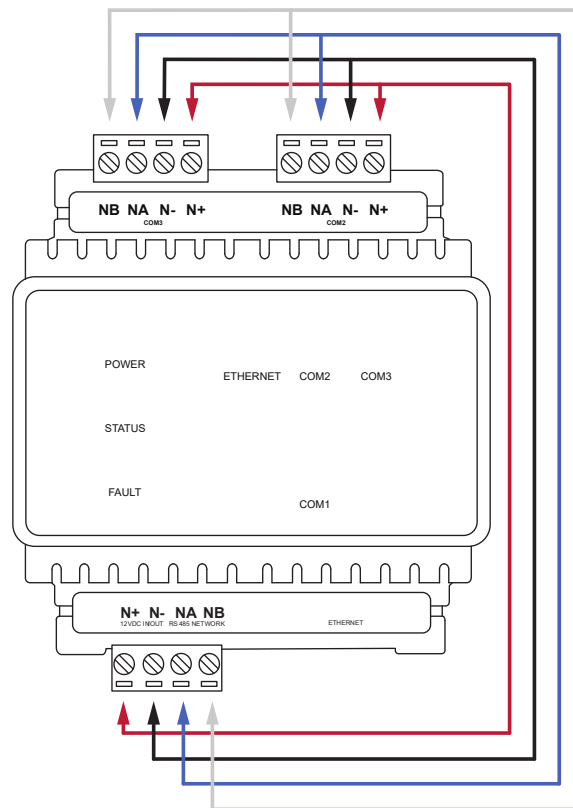

This achieves the following:

- Resets the password to admin
- Resets the **Repeater Mode** to RS-485 mode
- Resets the **UDP IP/Host** to 192.168.1.2

Note that this does not reset the IP address, so you may need to default the IP address separately (see page 17).

LED Indicators

Protege DIN rail modules feature comprehensive diagnostic indicators that can aid the installer in diagnosing faults and conditions. In some cases an indicator may have multiple meanings depending on the status indicator display at the time.

Power Indicator

The power indicator is lit when the correct input voltage is applied to the module.

Note that this indicator may take several seconds to light up after power has been applied.

State	Description
On (green)	Correct input voltage applied
Off	Incorrect input voltage applied

Status Indicator

The status indicator displays the status of the module.

State	Description
Continuous slow flash (green)	Module is operating normally
Constantly on (green)	Module is powering up

Fault Indicator

The fault indicator is lit any time the module is operating in a non-standard mode.

State	Description
Continuous slow (red) flash	Module is in boot mode awaiting firmware update

Ethernet Indicator

The ethernet indicator will show the status of the ethernet connection.

State	Description
Constantly on (green)	'Live' ethernet connection detected
Constantly off	No ethernet connection detected
Continuous (green) fast flash	Ethernet packet transmitted/received

COM Indicators

The COM indicators shows the status of the three COM ports.

State	Description
Constantly on (red)	COM port is not powered
Constantly on (green)	COM port is powered

Mechanical Diagram

The mechanical diagram below outlines the essential details needed to help ensure the correct installation of the network repeater.

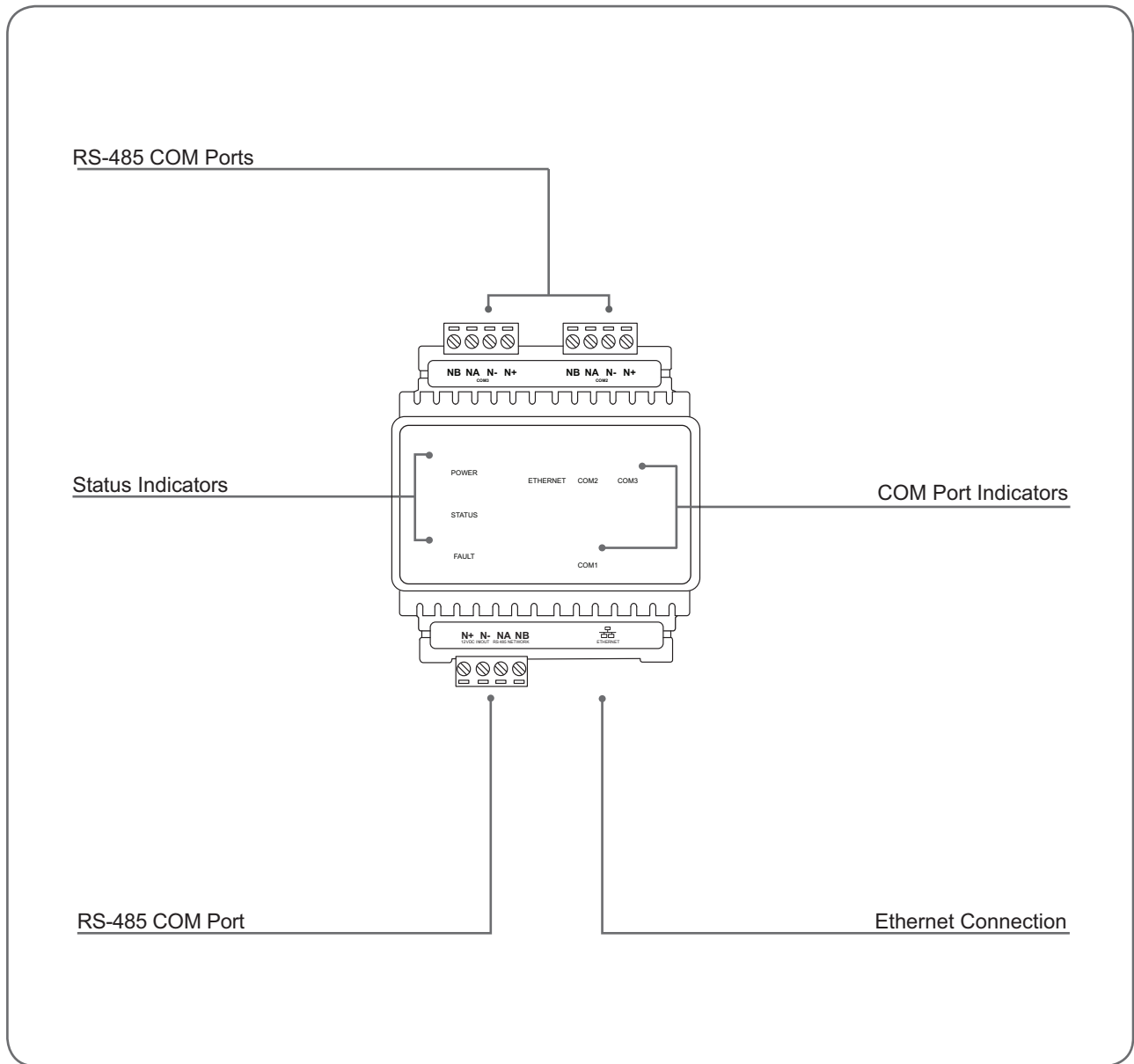

Mechanical Layout

The mechanical layout shown below outlines the essential details needed to help ensure correct installation and mounting. All measurements are shown in millimeters.

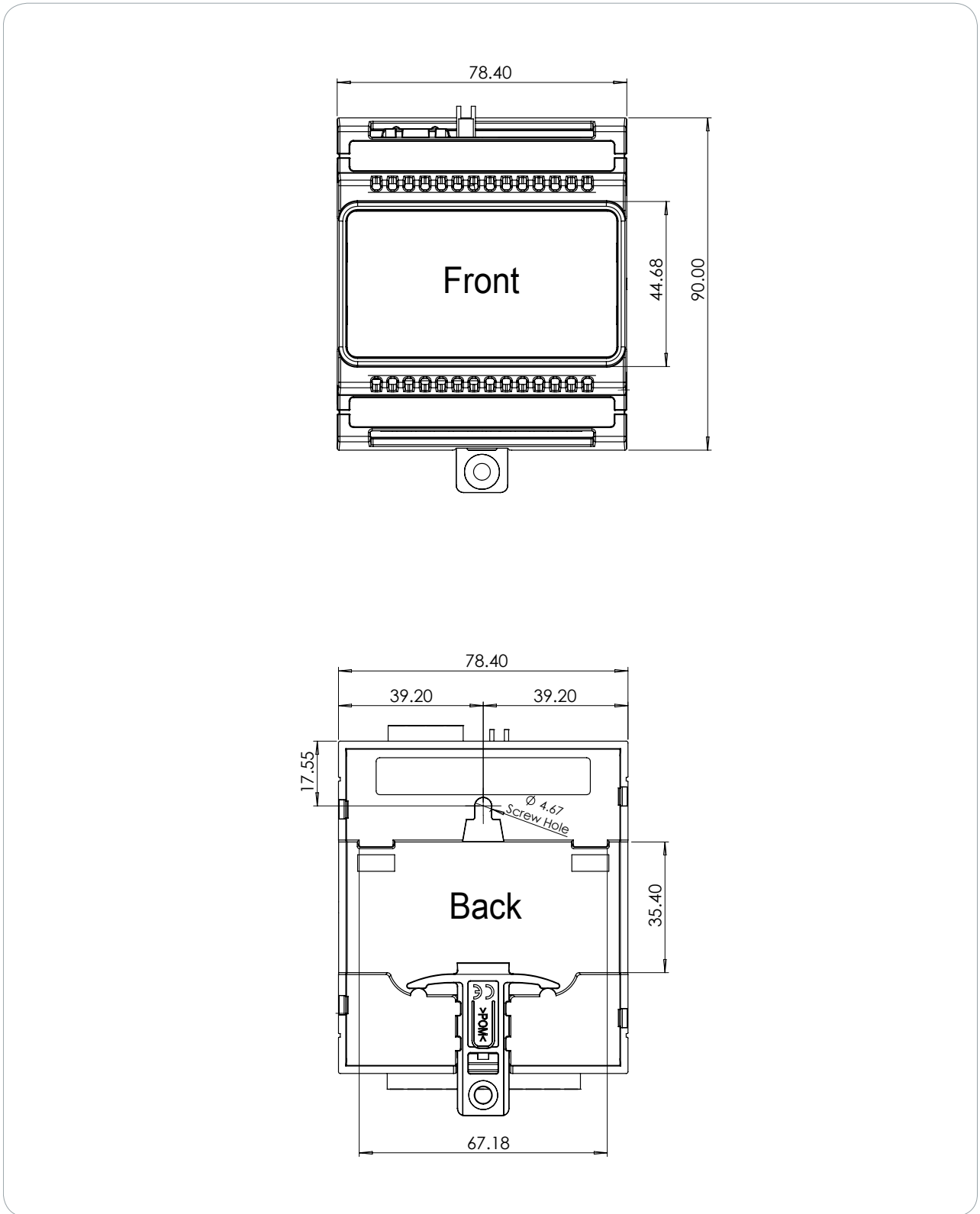

Technical Specifications

The following specifications are important and vital to the correct operation of this product. Failure to adhere to the specifications will result in any warranty or guarantee that was provided becoming null and void.

Ordering Information	
PRT-MNR2-DIN	Protege Module Network Repeater
Power Supply	
Operating Voltage	12V DC
Operating Current	65mA (Typical)
Communication	
RS-485	3 isolated RS-485 communication interface ports
Ethernet	1 10/100Mbps Ethernet Communication Link
Ports	Port 80 TCP/IP HTTP (Controller Web Interface) Fixed Port 9450 UDP/IP (Network Repeater to Controller)
Dimensions	
Dimensions (L x W x H)	78 x 90 x 60mm (3.1 x 3.5 x 2.4")
Net Weight	150g (5.3oz)
Gross Weight	220g (7.8oz)
Operating Conditions	
Operating Temperature	-10° to 55°C (14° to 131°F)
Storage Temperature	-10° to 85° C (14° to 185° F)
Humidity	0%-93% non-condensing, indoor use only (relative humidity)

It is important that the unit is installed in a dry cool location that is not affected by humidity. Do not locate the unit in air conditioning or a boiler room that can exceed the temperature or humidity specifications.

Integrated Control Technology continually strives to increase the performance of its products. As a result these specifications may change without notice. We recommend consulting our website (www.ict.co) for the latest documentation and product information.

New Zealand and Australia

General Product Statement

The RCM compliance label indicates that the supplier of the device asserts that it complies with all applicable standards.



ASIAL Class 5

This product is certified for AS/NZS 2201:2007 Class 5 installations as part of a compliant Protege GX or Protege WX system.

For more information, see the Protege GX / Protege WX AS/NZS 2201.1:2007 Class 5 Compliance Installer Guide, available from ICT.

European Standards

CE Statement

Conforms where applicable to European Union (EU) Low Voltage Directive (LVD) 2014/35/EU, Electromagnetic Compatibility (EMC) Directive 2014/30/EU, Radio Equipment Directive (RED) 2014/53/EU and RoHS Recast (RoHS2) Directive: 2011/65/EU + Amendment Directive (EU) 2015/863.

This equipment complies with the rules, of the Official Journal of the European Union, for governing the Self Declaration of the CE Marking for the European Union as specified in the above directive(s).



Information on Disposal for Users of Waste Electrical & Electronic Equipment

This symbol on the product(s) and / or accompanying documents means that used electrical and electronic products should not be mixed with general household waste. For proper treatment, recovery and recycling, please take this product(s) to designated collection points where it will be accepted free of charge.

Alternatively, in some countries you may be able to return your products to your local retailer upon purchase of an equivalent new product.

Disposing of this product correctly will help save valuable resources and prevent any potential negative effects on human health and the environment, which could otherwise arise from inappropriate waste handling.

Please contact your local authority for further details of your nearest designated collection point.

Penalties may be applicable for incorrect disposal of this waste, in accordance with your national legislation.

For business users in the European Union

If you wish to discard electrical and electronic equipment, please contact your dealer or supplier for further information.

Information on Disposal in other Countries outside the European Union

This symbol is only valid in the European Union. If you wish to discard this product please contact your local authorities or dealer and ask for the correct method of disposal.

EN50131 Standards

This component meets the requirements and conditions for full compliance with EN50131 series of standards for equipment classification.

EN 50131-1:2006+A2:2017, EN 50131-3:2009, EN 50131-6:2008+A1:2014, EN 50131-10:2014, EN 50136-1:2012, EN 50136-2:2013, EN 60839-11-1:2013

Security Grade 4

Environmental Class II

Equipment Class: Fixed

Readers Environmental Class: IVA, IK07

SP1 (PSTN – voice protocol)

SP2 (PSTN – digital protocol)

SP6 (LAN – Ethernet) and DP1 (LAN – Ethernet + PSTN)

SP6 (LAN – Ethernet) and DP1 (LAN – Ethernet + USB-4G modem)

Tests EMC (operational) according to EN 55032:2015

Radiated disturbance EN 55032:2015

Power frequency magnetic field immunity tests (EN 61000-4-8)

EN50131

In order to comply with EN 50131-1 the following points should be noted:

- Ensure for Grade 3 or 4 compliant systems, the minimum PIN length is set for 6 digits.
- To comply with EN 50131-1 Engineer access must first be authorized by a user, therefore Installer codes will only be accepted when the system is unset. If additional restriction is required then Engineer access may be time limited to the first 30 seconds after the system is unset.
- Reporting delay –Violation off the entry path during the entry delay countdown will trigger a warning alarm. The warning alarm should not cause a main alarm signal and is not reported at this time. It can be signaled locally, visually and or by internal siren type. If the area is not disarmed within 30 seconds, the entry delay has expired or another instant input is violated, the main alarm will be triggered and reported.
- To comply with EN 50131-1 neither Internals Only on Part Set Input Alarm nor Internals Only on Part Set Tamper Alarm should be selected.
- To comply with EN 50131-1 Single Button Setting should not be selected.
- To comply with EN 50131-1, only one battery can be connected and monitored per system. If more capacity is required, a single larger battery must be used.
- For Security Grade 4 installations, two forms of reporting are required. This can be satisfied using the onboard 2400bps modem included with the modem controller model, or through the incorporation of the PRT-4G-USB cellular modem module into the installation with the non-modem controller model.

Anti Masking

To comply with EN 50131-1 Grade 3 or 4 for Anti Masking, detectors with a separate or independent mask signal should be used and the mask output should be connected to another input.

I.e. Use 2 inputs per detector. One input for alarm/tamper and one input for masking.

To comply with EN 50131-1:

- Do not fit more than 10 unpowered detectors per input,
- Do not fit more than one non-latching powered detector per input,
- Do not mix unpowered detectors and non-latching powered detectors on an input.

To comply with EN 50131-1 the Entry Timer should not be programmed to more than 45 seconds.

To comply with EN 50131-1 the Bell Cut-Off Time should be programmed between 02 and 15 minutes.

EN 50131-1 requires that detector activation LEDs shall only be enabled during Walk Test. This is most conveniently achieved by using detectors with a Remote LED Disable input.

To comply with EN 50131-1, EN 60839-11 Security Grade 4 and AS/NZS2201.1 class 4&5 Vibration Detection for PreTamper Alarm, protection is provided by a DSC SS-102 Shockgard Seismic vibration sensor mounted within the system enclosure. Alarm output is provided by a pair of non-latching, N.C. (normally closed) relay contacts, opening for a minimum of 1 second on detection of an alarm connected in series with the 24Hr tamper input (TP) on the PSU (or any other system input designated/programmed as a 24Hr Tamper Alarm).

This relay is normally energized to give fail-safe operation in the event of a power loss. Indication of detection is provided by a LED situated on the front cover. The vibration sensor is fully protected from tampering by a N.C. micro switch operated by removal of the cover.

Enclosure EN-DIN-24 has been tested and certified to EN50131.

By design, the enclosures for all Integrated Control Technology products, EN-DIN-11, EN-DIN-12 and EN-DIN-24-ATTACK, comply with the EN 50131 standards. Tamper protection against removal of the cover as well as removal from mounting is provided by tamper switch.

Warning: Enclosures supplied by 3rd parties may not be EN50131-compliant, and should not be claimed as such.

UK Conformity Assessment Mark

General Product Statement

The UKCA Compliance Label indicates that the supplier of the device asserts that it complies with all applicable standards.



FCC Compliance Statements

FCC Rules and Regulations CFR 47, Part 15, Subpart B

This equipment complies with the limits for a Class A digital device, pursuant to Part 15 of the FCC rules.

Operation is subject to the following two conditions:

- This device may not cause harmful interference.
- This device must accept any interference received, including interference that may cause undesired operation.

NOTE: THE GRANTEE IS NOT RESPONSIBLE FOR ANY CHANGES OR MODIFICATIONS NOT EXPRESSLY APPROVED BY THE PARTY RESPONSIBLE FOR COMPLIANCE. SUCH MODIFICATIONS COULD VOID THE USER'S AUTHORITY TO OPERATE THE EQUIPMENT.

Industry Canada Statement

ICES-003

This class A digital apparatus complies with Canadian ICES-003.

Cet appareil numérique de la classe A est conforme à la norme NMB-003 du Canada.

CAN ICES-3 (A)/NMB-3(A)

Disclaimer and Warranty

Disclaimer: Whilst every effort has been made to ensure accuracy in the representation of this product, neither Integrated Control Technology Ltd nor its employees shall be liable under any circumstances to any party in respect of decisions or actions they may make as a result of using this information. In accordance with the ICT policy of enhanced development, design and specifications are subject to change without notice.

For warranty information, see our [Standard Product Warranty](#).

Designers & manufacturers of integrated electronic access control, security and automation products.
Designed & manufactured by Integrated Control Technology Ltd.
Copyright © Integrated Control Technology Limited 2003-2026. All rights reserved.

Disclaimer: Whilst every effort has been made to ensure accuracy in the representation of this product, neither Integrated Control Technology Ltd nor its employees shall be liable under any circumstances to any party in respect of decisions or actions they may make as a result of using this information. In accordance with the ICT policy of enhanced development, design and specifications are subject to change without notice.