



PRT-RDM2-DIN-485

Protege DIN Rail 2 Door Reader Expander

Installation Manual



The specifications and descriptions of products and services contained in this document were correct at the time of printing. Integrated Control Technology Limited reserves the right to change specifications or withdraw products without notice. No part of this document may be reproduced, photocopied, or transmitted in any form or by any means (electronic or mechanical), for any purpose, without the express written permission of Integrated Control Technology Limited. Designed and manufactured by Integrated Control Technology Limited, Protege® and the Protege® Logo are registered trademarks of Integrated Control Technology Limited. All other brand or product names are trademarks or registered trademarks of their respective holders.

Copyright © Integrated Control Technology Limited 2003-2026. All rights reserved.

Last Published: 21-Jan-26 1:01 PM

Contents

Introduction	5
Installation Requirements	6
Wiring	6
Grounding Requirements	7
Safety Grounding	7
Earth Ground Connection	7
Mounting	9
Removal	9
Wiring Diagram	10
DC Power & Encrypted Module Network	11
End-of-Line (EOL) Resistors	11
Door Access Control	12
Shield Connection	12
RS-485 Reader Connection	13
RS-485 Reader Connection (Entry/Exit)	14
RS-485 Reader Location	14
OSDP Reader Connection	15
OSDP Reader Location	15
Wiegand Reader Connection	16
Single LED Connection	16
Dual LED Connection	17
Multiple Wiegand Reader Connection	18
Connecting 4 Wiegand Readers	19
Magnetic Reader Connection	20
Door Contact Connection	20
Door Lock Connection	21
Inputs	22
Trouble Inputs	23
Door Trouble Inputs	23
Outputs	24
Lock Outputs (1 and 2)	24
Standard Outputs (3 To 8)	24
Beeper Outputs (5 and 8)	25
Address Configuration	26

LED Indicators	27
Status Indicator	27
Fault Indicator	27
Power Indicator	27
Relay Indicators	27
Reader 1/Reader 2 Indicators	28
Input Indicators	28
Error Code Indication	29
Error Code Display	29
Mechanical Diagram	30
Mechanical Layout	31
Technical Specifications	32
New Zealand and Australia	34
ASIAL Class 5	34
European Standards	35
UK Conformity Assessment Mark	37
UL and cUL Installation Requirements	38
UL/cUL Enclosures	38
cUL Compliance Requirements	38
CAN/ULC-60839-11-1	38
CAN/ULC-S319	38
UL Compliance Requirements	39
UL294	39
FCC Compliance Statements	40
Industry Canada Statement	41
Disclaimer and Warranty	42

Introduction

The Protege DIN Rail 2 Door Reader Expander extends the number of card reader inputs on the system by 2 (or 4 when using multiple reader mode), the number of inputs by 8 (four inputs used for door monitoring and control and up to eight can be used for extended functionality) and the number of outputs by 8 (includes 2 relay lock control outputs).

Flexible module network architecture allows large numbers of modules to be connected to the RS-485 module network. Up to 250 modules can be connected to the Protege system in any combination to the network, over a distance of up to 900M (3000ft). Further span can be achieved with the use of a network repeater module.

The current features of the reader expander include:

- 4 Wiegand reader mode for 2 Entry/Exit doors per reader expander
- 4 RS-485 reader mode for 2 Entry/Exit doors per reader expander
- RS-485 reader port connections support configuration for OSDP protocol
- Secure encrypted RS-485 module communications
- 8 inputs
- 2 lock Form C Relay outputs
- 6 open collector outputs (reader control outputs)
- Smart reader missing/tamper monitoring
- Offline functions including All Users, First 10 Users plus 150 Card Cache and No Users
- Online and remote upgradeable firmware
- Industry-standard DIN rail mounting

Installation Requirements

This equipment is to be installed in accordance with:

- The product installation instructions
- UL 294 - Access Control System Units
- UL 681 - Installation and Classification of Burglar and Holdup Systems
- UL 827 - Central-Station Alarm Services
- CAN/ULC-S301, Central and Monitoring Station Burglar Alarm Systems
- CAN/ULC-S302, Installation and Classification of Burglar Alarm Systems for Financial and Commercial Premises, Safes and Vaults
- CAN/ULC-S561, Installation and Services for Fire Signal Receiving Centres and Systems
- CAN/ULC-60839-11-1, Alarm and Electronic Security Systems – Part 11-1: Electronic Access Control Systems – System and Components Requirements
- The National Electrical Code, ANSI/NFPA 70
- The Canadian Electrical Code, Part I, CSA C22.1
- AS/NZS 2201.1 Intruder Alarm Systems
- The Local Authority Having Jurisdiction (AHJ)

Wiring



For UL/cUL installations, the following wiring specifications must be observed.

Input Wiring: Maximum distance of 300m (1000ft) from the connected module when using 22 AWG.

Aux Wiring: Minimum 22AWG, maximum 16AWG (depends on length and current consumption).

For wire/cable size, a maximum of 5% voltage drop at the terminals of the powered device must be observed.

Module Network Wiring:

- Minimum 24AWG (0.51mm) shielded twisted pair with characteristic impedance of 120Ω. Maximum length 900m (3000ft).
- CAT5e / CAT6 also supported for data transmission when using ground in the same cable. Maximum length 100m (330 ft).

Do not use extra wires in the cable to power devices.

Grounding Requirements

An effectively grounded product is one that is intentionally connected to earth ground through a ground connection or connections of sufficiently low impedance and having sufficient current-carrying capacity to prevent elevated voltages that may result in undue hazard to connected equipment or to persons.

Grounding of the Protege system is done for three basic reasons:

1. Safety
2. Component protection
3. Noise reduction

Safety Grounding

The object of safety grounding is to ensure that all metalwork is at the same ground (or earth) potential. Impedance between the Protege system and the building scheme ground must conform to the requirements of national and local industrial safety regulations or electrical codes. These will vary based on country, type of distribution system and other factors. The integrity of all ground connections should be checked periodically.

General safety dictates that all metal parts are connected to earth with separate copper wire or wires of the appropriate gauge.

Warning: All cabinet internal covers and lids/doors must be connected to the cabinet's main ground point for electrical safety and static discharge protection.

Earth Ground Connection

The DIN rail enclosure and the DIN rail modules must be grounded to a suitable single-point earth ground connection in the installation. A minimum 14AWG solid copper wire (or thicker, in accordance with local authorities) shall be used from the Protege system's earth connection points.

The DIN rail enclosure includes an earth ground single-point link connection via the metallic enclosure. This single-point link is the Protege system's earth ground. All modules that have earth ground connections and that are installed in the same enclosure shall be connected to this single point. A single-point earth ground connection avoids the creation of ground loops in the system and provides a single reference point to earth ground.

DIN Rail Ground Connections (one or more cabinets installed in the same room)

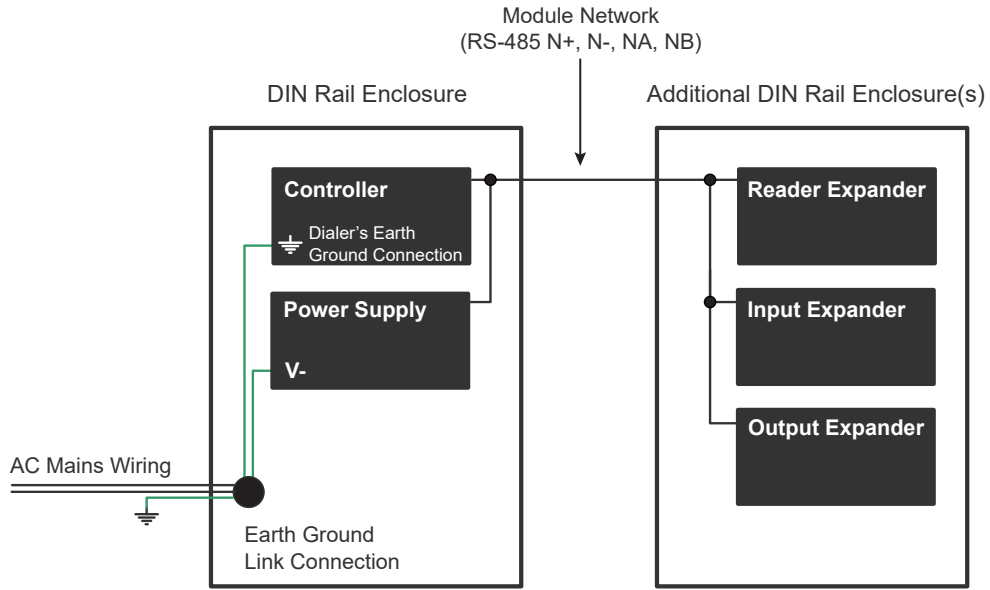

DIN Rail Ground Connections (multiple cabinets in different rooms, sectors, or buildings)

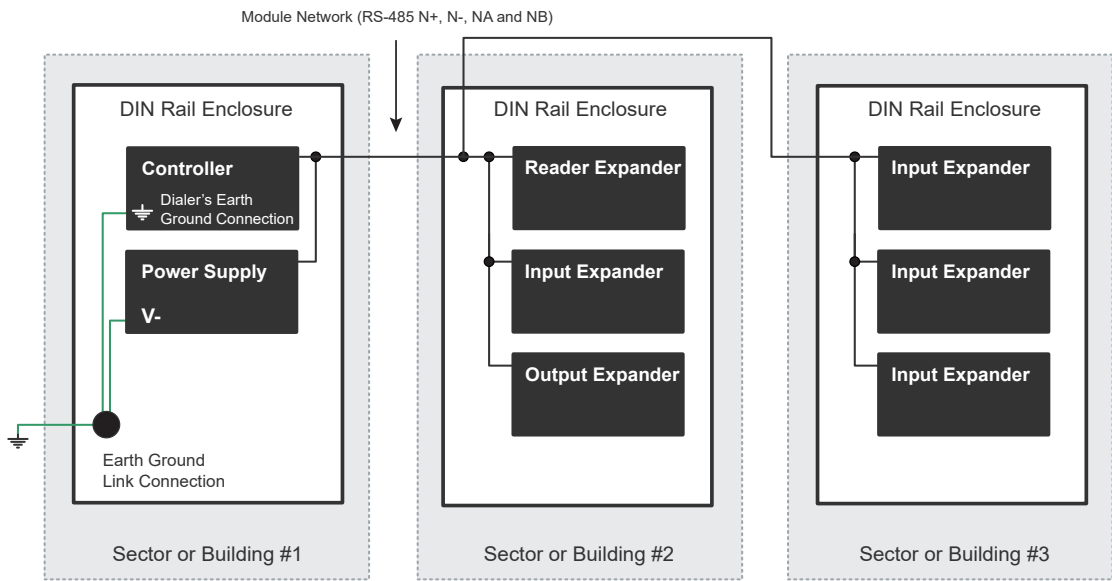

The Dialer's Earth Ground Connection applies to modem model controllers only.

Note that the DIN rail enclosure earth terminal is connected to the power supply V- terminal.

There must be only **one** single earth grounding point per system.

Mounting

Protege DIN rail modules are designed to mount on standard DIN rail, either in dedicated DIN cabinets or on generic DIN rail mounting strip.

Location

Protege DIN rail modules must be installed indoors, within the protected area. Modules must be protected by a secure cabinet with tamper detection.

We recommend installing the cabinet in a location that provides easy access for wiring. Suitable locations include electrical rooms, communication equipment rooms and accessible areas of the ceiling. Ensure that there is adequate clearance around each device and that air flow to the vents is not restricted.

Protege DIN rail modules must not be installed outdoors. Ensure that the room does not exceed or fall below the operating temperature or humidity ranges listed in the Technical Specifications for each module. Do not mount cabinets on the exterior of a vault, safe or stockroom.



For UL/cUL installations, you must use a UL- or cUL-listed enclosure. See the full certification list in the UL/cUL-Listed Protege Enclosures document, available from the ICT website.

All cabinet installations of this type must be located **inside the Protected Area. Not** to be mounted on the exterior of a vault, safe or stockroom.

Mounting a DIN Rail Module

To mount a module onto DIN rail:

1. Position the module with the labeling in the correct orientation.
2. Hook the mounting tabs (opposite the tab clip) under the edge of the DIN rail.
3. Push the DIN rail module against the mount until the tab clips over the rail.

Removal

To remove the DIN rail module from the DIN rail mount:

1. Insert a flat-blade screwdriver into the slot in the module tab clip.
2. Lever the tab outwards and rotate the unit off the DIN rail mount.

Wiring Diagram

Notice: Incorrect wiring may result in damage to the unit.

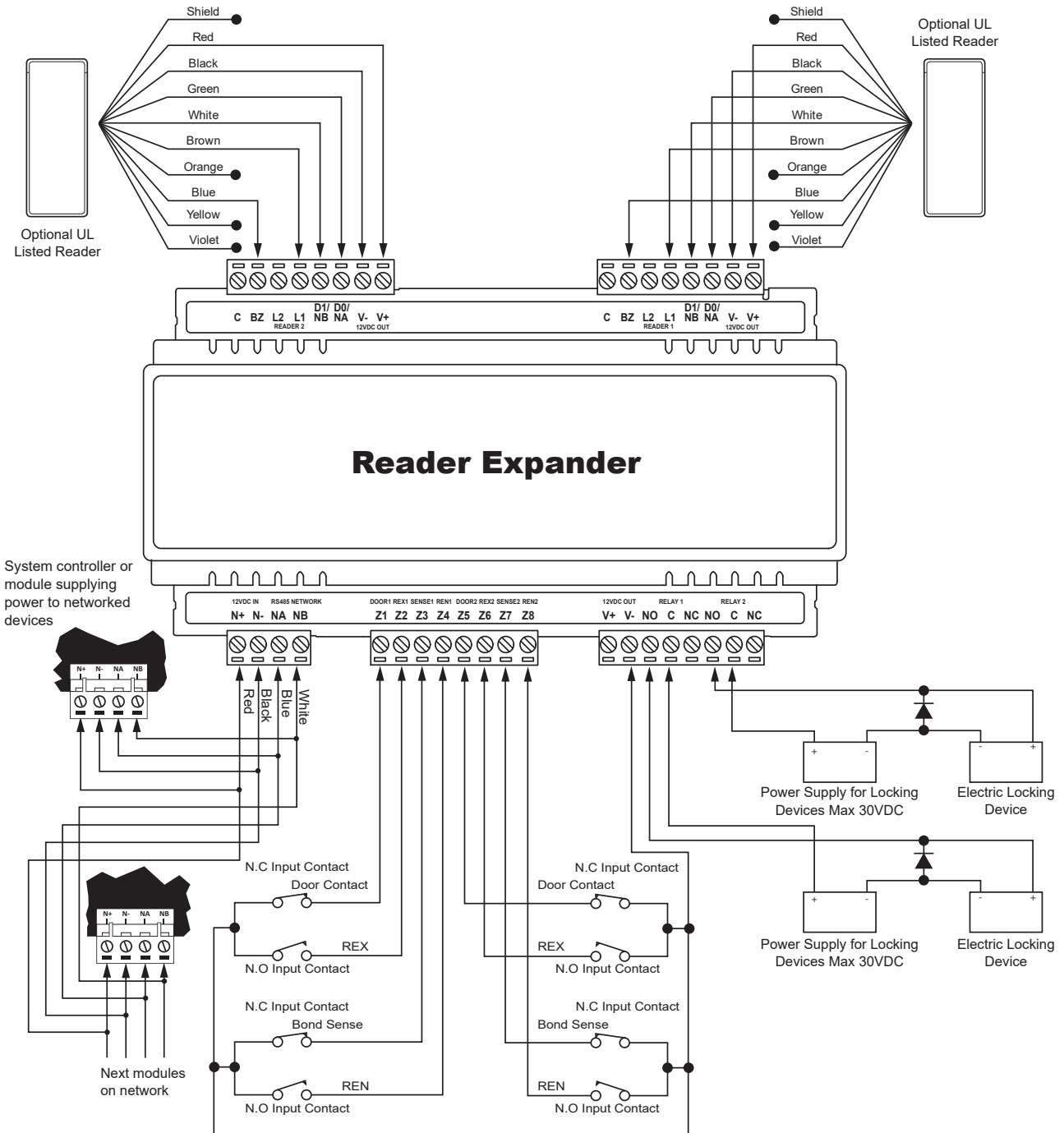

DC Power & Encrypted Module Network

The expander incorporates encrypted RS-485 communications technology, and both module and network power are supplied by the N+ and N- terminals.

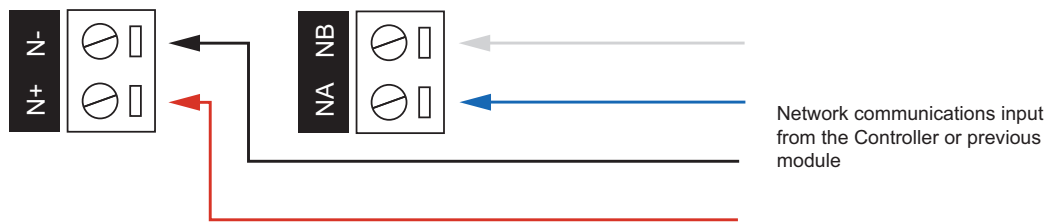

Connection of the communications and DC supply should be performed according to the diagram shown above. It is important that the N+ network communications power be 12VDC supplied from an independent battery backed power supply unit capable of supplying the required voltage to all devices on the RS-485 network.

Warning: The 12V N+ and N- communication input must be supplied from only **one** point. Connections from more than one 12V supply may cause failure or damage to the unit or the device supplying network power.

End-of-Line (EOL) Resistors

End-of-line resistors prevent signal reflections at the ends of the RS-485 network bus, improving signal strength and reducing data corruption.

You must insert a **120Ω resistor** between the NA and NB terminals of the **first** and **last** modules on the RS-485 network. These are the modules physically located at the ends of the RS-485 network cabling.

First Module on RS-485 Network

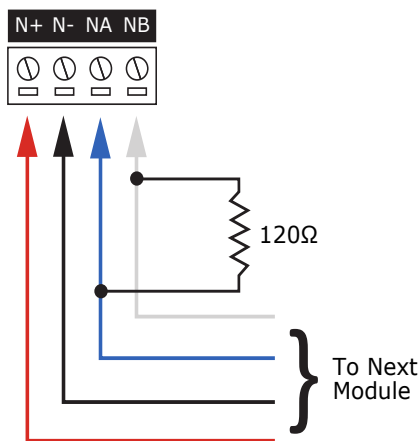

Last Module on RS-485 Network

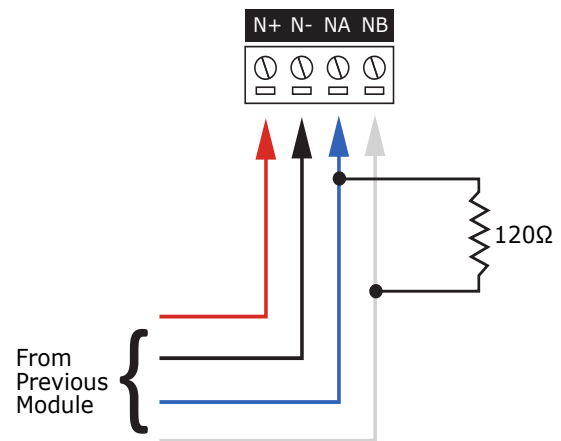

Door Access Control

The reader expander allows the connection of up to 4 reading devices controlling 2 doors with entry and exit readers. Each reader port can be independently configured to support one of the following protocols:

- ICT RS-485 (ICT readers only)
- OSDP (Open Supervised Device Protocol)
- Wiegand

Recommended Cabling

The recommended cable specifications for ICT RS-485 and OSDP are:

- Minimum 24AWG (0.51mm) shielded twisted pair with characteristic impedance of 120 ohm
- Maximum distance: 900m (3000ft)

Wiegand cables are **not** suitable for ICT RS-485 and OSDP connections. RS-485 communications over Wiegand data lines are affected by interference between the data wires, which can cause corrupted card reads and readers dropping offline. If you are transitioning a site from Wiegand to RS-485, we strongly recommend that you replace the existing Wiegand cables with shielded twisted pair cables.

The recommended cable specifications for Wiegand are:

- 22AWG alpha 5196, 5198, 18AWG alpha 5386, 5388
- Maximum distance: 150m (492ft)



All UL listed ICT readers are shipped with single LED mode set as default and are fully compatible with the Protege system.

Shield Connection

- Use a shielded cable to connect the card reader to the module port.
- Frame ground the shield to the metallic enclosure at one end only.
- Do not connect the cable shield to an AUX-, OV or V- connection on the module.
- Do not connect the cable shield to any shield used for isolated communication.
- The reader pigtail shield and cable shield wires should be joined at the reader pigtail splice.
- Do not terminate the reader shield wire inside the reader.

Note: The reader and cable shield wires must be joined at the reader pigtail splice for all MIFARE capable ICT card readers. Older readers which are internally grounded and third-party readers do not require the shield wires to be joined. For further information, contact ICT Technical Support.

Always refer to the card reader manufacturer for detailed installation guidelines.

RS-485 Reader Connection

ICT readers can be connected to a Protege reader expander in RS-485 configuration. The following shows the connection of a single RS-485 reader for entry only.

Third-party RS-485 readers can only be connected using the OSDP protocol (see page 15).

Reader Port Connections

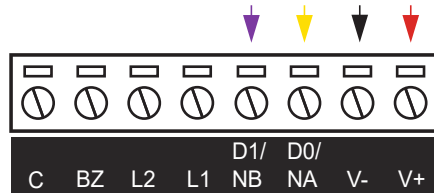

Reader Wiring Connections

The reader should be connected using the wiring configuration outlined in the table below.

Reader Wire	Connection
12VDC+ positive	V+ 12VDC positive
12VDC- negative	V- 12VDC negative
RS-485 A	D0/NA RS-485 A
RS-485 B	D1/NB RS-485 B
Shield (drain)	Frame grounded at one point only

RS-485 Reader Connection (Entry/Exit)

The following shows the connection of two RS-485 readers to provide an entry/exit configuration.

Reader Port Connections

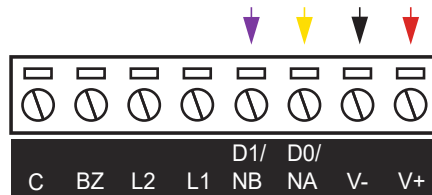

Primary Reader Wiring Connections

The primary reader should be connected using the wiring configuration outlined in the table below.

Reader Wire	Connection
12VDC+ positive	V+ 12VDC positive
12VDC- negative	V- 12VDC negative
RS-485 A	DO/NA RS-485 A
RS-485 B	D1/NB RS-485 B
Shield (drain)	Join the shield (drain) wires together. Frame grounded at one point only

Secondary Reader Wiring Connections

The secondary reader should be connected using the wiring configuration outlined in the table below.

Reader Wire	Connection
12VDC+ positive	Join to primary reader 12VDC+ positive wire
12VDC- negative	Join to primary reader 12VDC- negative wire
RS-485 A	Join to primary reader RS-485 A wire
RS-485 B	Join to primary reader RS-485 B wire
Shield (drain)	Join the shield (drain) wires together. Frame grounded at one point only

RS-485 Reader Location

As two RS-485 readers can be connected to the same reader port, the reader **address** uniquely identifies each reader and determines which is the entry reader and which is the exit reader.

Configuration	Location
Reader address = 0	Entry
Reader address = 1	Exit

All ICT readers use address 0 (entry) by default, unless configured otherwise. The reader's address can be configured by applying the required reader address TLV setting to the reader programming.

For programming instructions, see the ICT Card Reader Configuration Guide, available from the ICT website.

tSec readers are hardwired to use address 1 when the reader's **green** and **orange** wires are joined together. For more information, see the tSec reader installation manual.

OSDP Reader Connection

When using the OSDP protocol the reader is connected to the reader port using a standard RS-485 wiring configuration. The following shows the connection of a single OSDP reader for entry only.

Connection of two OSDP readers to provide an entry/exit configuration follows the same connection requirements as connecting two RS-485 readers (see previous page).

Reader Port Connections

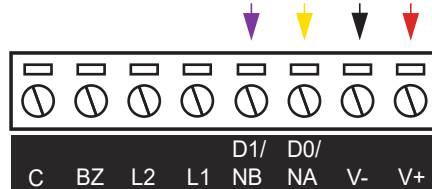

This connection example shows wiring for ICT readers. Other readers may use different color configurations. Always refer to the card reader manufacturer for detailed installation guidelines, and see the table below.

Reader Wiring Connections

The reader should be connected using the wiring configuration outlined in the table below.

Reader Wire	Connection
12VDC+ positive	V+ 12VDC positive
12VDC- negative	V- 12VDC negative
RS-485 A	D0/NA RS-485 A
RS-485 B	D1/NB RS-485 B
Shield (drain)	Frame grounded at one point only

Consult the manufacturer's documentation for wiring instructions for the specific reader being connected.

Connecting OSDP readers to Protege modules requires additional hardware configuration and system programming. For more information, see [Application Note 254: Configuring OSDP Readers in Protege](#).

For more information about OSDP support on ICT card readers, including configuring readers for secure channel communications, see [Application Note 321: Configuring ICT Readers for OSDP Communication](#).

OSDP Reader Location

You can connect two OSDP readers to each Protege module's reader port. Each OSDP reader is configured as either an Entry or Exit reader in the **Reader location** setting of the associated **smart reader** record.

The default addresses are 0 for entry and 1 for exit. However, these can be any two unique addresses from 0-127. OSDP reader location is **not** determined by the reader address.

Wiegand Reader Connection

When connecting a reader to a Protege reader expander using the Wiegand interface, the reader can be wired in either single or dual LED configuration.

Only card readers with two Wiegand LED lines support dual LED operation.

Single LED Connection

Single LED operation is the standard Wiegand configuration and allows a single LED line to control the two reader LEDs. This results in two possible LED states: color 1 or color 2.

All ICT readers are shipped to operate in single LED mode by default.

The following shows the wiring configuration of a Wiegand reader for entry only, using single LED operation.

Reader Port Connections

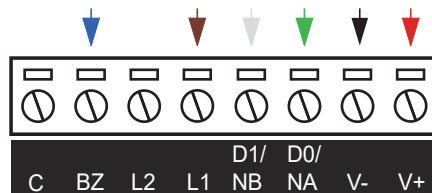

This connection example shows wiring for ICT readers. Other readers may use different color configurations. Always refer to the card reader manufacturer for detailed installation guidelines, and see the table below.

Reader Wiring Connections

The reader should be connected using the wiring configuration outlined in the table below.

Reader Wire	Connection
12VDC+ positive	V+ 12VDC positive
12VDC- negative	V- 12VDC negative
Wiegand Data 0	D0/NA Wiegand Data 0
Wiegand Data 1	D1/NB Wiegand Data 1
Wiegand LED control	L1 Wiegand LED control
Wiegand beeper control	BZ Wiegand beeper control
Shield (drain)	Frame grounded at one point only

Dual LED Connection

Dual LED operation uses two LED lines to independently control the two LEDs. This results in four possible LED states: color 1, color 2, both colors on (produces a third, combined color), or both colors off. The additional states may be used to show the status of alarms or other integrated signals.

The reader must support dual LED operation. ICT tSec readers support this functionality, however the reader needs to be programmed to operate in dual LED mode. For programming instructions, see the ICT Card Reader Configuration Guide, available from the ICT website.

The following shows the wiring configuration of a Wiegand reader for entry only, using dual LED operation.

Reader Port Connections

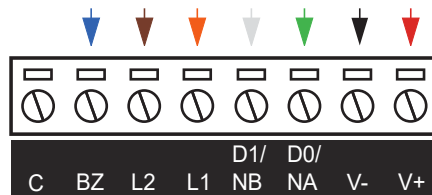

This connection example shows wiring for ICT readers. Other readers may use different color configurations. Always refer to the card reader manufacturer for detailed installation guidelines, and see the table below.

Reader Wiring Connections

The reader should be connected using the wiring configuration outlined in the table below.

Reader Wire	Connection
12VDC+ positive	V+ 12VDC positive
12VDC- negative	V- 12VDC negative
Wiegand Data 0	D0/NA Wiegand Data 0
Wiegand Data 1	D1/NB Wiegand Data 1
Wiegand LED 1 control	L1 Wiegand LED 1 control
Wiegand LED 2 control	L2 Wiegand LED 2 control
Wiegand beeper control	BZ Wiegand beeper control
Shield (drain)	Frame grounded at one point only

Multiple Wiegand Reader Connection

In multiple reader mode, the secondary card reader has all connections wired to the same reader port as the primary reader, except the Data 1 connection which is wired to the Data 1 input on the alternate reader port.

The normal primary reader connection operates as the **entry** reader, and the secondary reader that is multiplexed into the alternate reader port will operate as the **exit** reader.

To connect two Wiegand readers to a reader port the **Multiple reader input port 1/2** option must be enabled in the reader expander programming. When this option is disabled the reader port will only process a single reader.

The following shows the connection of two Wiegand readers to provide an entry/exit configuration.

Reader Port Connections

This example assumes the standard single LED configuration. For dual LED operation connect the primary reader port as described in the previous topic.

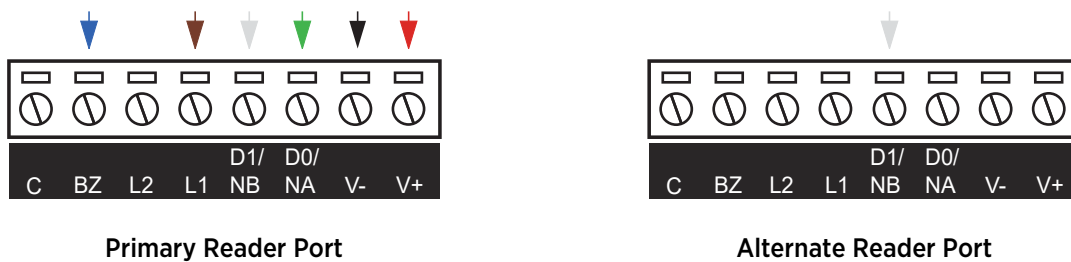

This connection example shows wiring for ICT readers. Other readers may use different color configurations. Always refer to the card reader manufacturer for detailed installation guidelines, and see the table below.

Entry Reader Wiring Connections

The entry reader should be connected using the wiring configuration outlined in the table below.

Reader Wire	Connection
12VDC+ positive	V+ 12VDC positive
12VDC- negative	V- 12VDC negative
Wiegand Data 0	DO/NA Wiegand Data 0
Wiegand Data 1	D1/NB Wiegand Data 1
Wiegand LED control	L1 Wiegand LED control
Wiegand beeper control	BZ Wiegand beeper control
Shield (drain)	Join the shield (drain) wires together. Frame grounded at one point only

Exit Reader Wiring Connections

The exit reader should be connected using the wiring configuration outlined in the table below.

Reader Wire	Connection
12VDC+ positive	Join to entry reader 12VDC+ positive wire
12VDC- negative	Join to entry reader 12VDC- negative wire
Wiegand Data 0	Join to entry reader Wiegand Data 0 wire
Wiegand Data 1	D1/NB Wiegand Data 1 (alternate reader port to entry reader)
Wiegand LED control	Join to entry reader Wiegand LED control wire
Wiegand beeper control	Join to entry reader Wiegand beeper control wire
Shield (drain)	Join the shield (drain) wires together. Frame grounded at one point only

Connecting 4 Wiegand Readers

Multiple reader mode allows the connection of 4 Wiegand readers controlling 2 doors, each with entry and exit readers. To connect 4 Wiegand reading devices:

- Door 1 entry reader is connected to reader **port 1**
- Door 1 exit reader has its Wiegand Data 1 wire connected to the reader **port 2** D1 connection
- Door 2 entry reader is connected to reader **port 2**
- Door 2 exit reader has its Wiegand Data 1 wire connected to the reader **port 1** D1 connection
- The **Multiple reader input port 1** option is enabled in the reader expander programming (General | Options)
- The **Multiple reader input port 2** option is enabled in the reader expander programming (General | Options)

To connect two Wiegand readers to a reader port the **Multiple reader input port 1/2** option must be enabled in the reader expander programming. When this option is disabled the reader port will only process a single reader.

Magnetic Reader Connection

The reader expander allows the connection of standard magnetic track 2 format cards and provision is made in the software for a large number of formats. Formats include BIN number for ATM access control and first 4, 5 and 6 card numbers.

Magnetic Card Reader Interface:

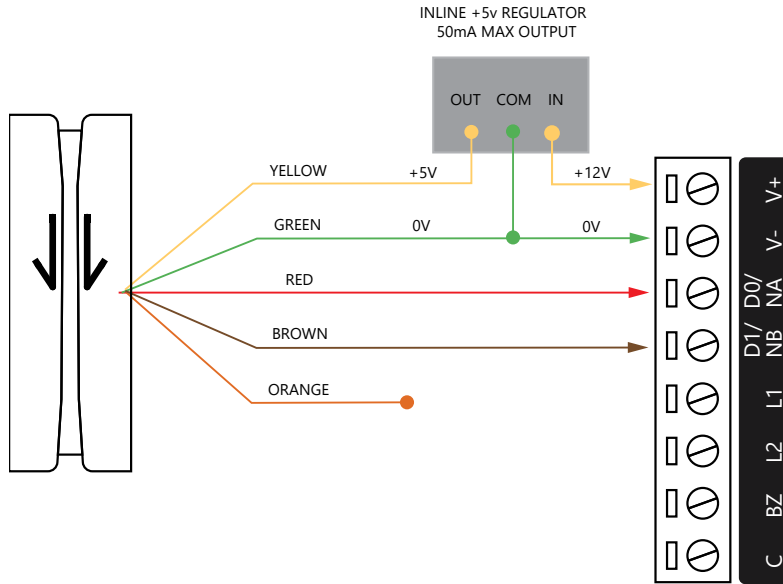

Magnetic card readers are typically operated by 5 volts. Before connecting the magnetic card reader to the reader expander, ensure that the supply voltage is correct and if required insert the inline 5 volt regulator as shown in the diagram above.

Door Contact Connection

The module allows the connection of up to 4 contacts for monitoring and controlling access control doors. Each input can be used for either the door function that is automatically assigned or as a normal input on the system. The following example shows the connection of a normally closed door position monitoring contact to monitor the open, closed, forced and alarm conditions of the door.

Standard Door Contact Inputs:

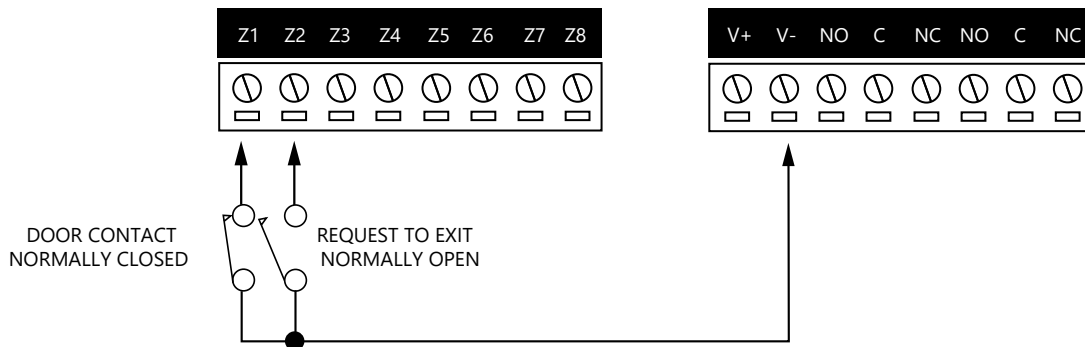

When connected the REX input can be programmed to operate regardless of the door contact state. The REX input can also be programmed to recycle the door alarm time to prevent nuisance alarms when the door is held open to permit longer entry.

Door Lock Connection

The reader expander provides two lock output relays that can be used to switch electric locks.

Door Lock Outputs:

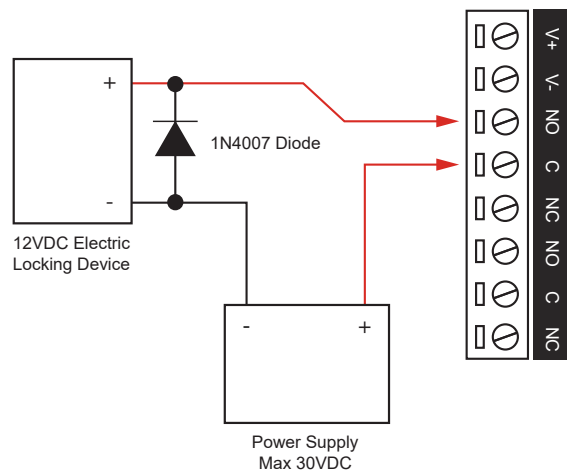

The locking device is connected to the **NO** terminal, as displayed above, for power to unlock / fail secure devices. For power to lock / fail safe devices the locking device is connected to the **NC** terminal.

The 1N4007 diode is supplied for lock output connections and **must** be installed at the electric strike terminals.

Warning: Relay outputs can switch to a maximum capacity of 7A. Exceeding 7A will damage the output.

Inputs

The reader expander can monitor the state of up to 8 inputs. These inputs can be connected to a variety of EOL monitored or dry contact devices such as magnetic switches and PIR motion detectors. Devices connected to the inputs can be installed to a maximum distance of 300m (1000ft) from the module when using 22 AWG wire. Each input may be individually configured for normally opened and normally closed configurations with or without EOL resistors for tamper and short condition monitoring.



- Magnetic contacts shall be listed to UL 634 to comply with UL installation standards and ULC/ORD-C634 to comply with cUL installation standards.
- Motion detectors and temperature sensors shall be listed to UL 639 to comply with UL installation standards and ULC-S306 to comply with cUL installation standards.
- The reader expander has been evaluated for UL 294 and CAN/ULC-S319 standalone access control.

When using an input with the EOL resistor configuration, the controller generates an alarm condition when the state of an input changes between open and closed and generates a tamper alarm condition when a wire fault (short circuit) or a cut wire (tampered) in the line occurs.

When using the EOL resistor configuration, the EOL resistor option must be enabled in the input programming so that the tamper and short states can be monitored. For more information, refer to your Protege programming reference manual.

EOL Resistor Input Configuration:

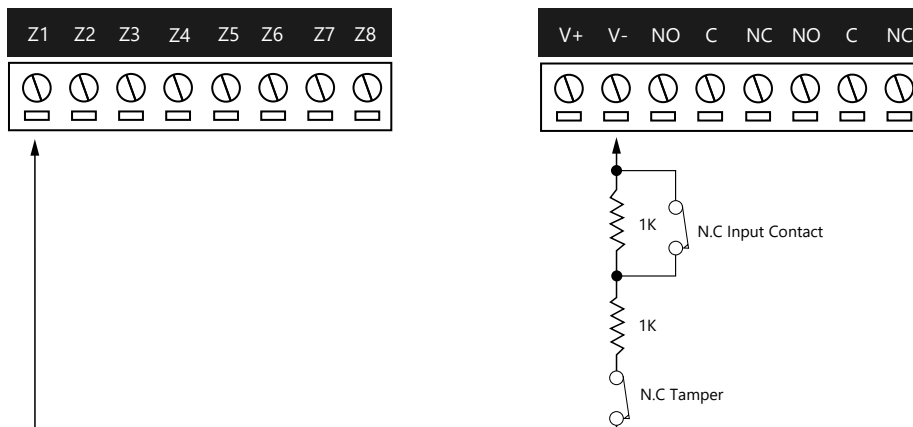

For the input ground connection, you may use the **V-** terminal on the lock output block or the **C** terminals on the reader ports.

Each input can use a different input configuration. To program a large number of inputs with the same configuration use the multiple selection feature within the Protege software.

When using the 'No Resistor' configuration the controller only monitors the opened and closed state of the connected input device, generating the alarm (open) and restore (closed/sealed) conditions.

No EOL Resistor Input Configuration:

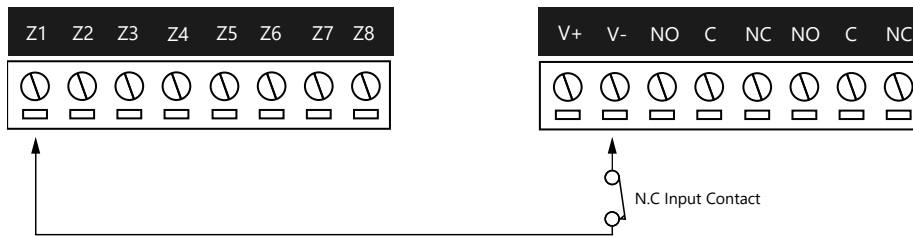

Trouble Inputs

Each reader expander can monitor up to 16 trouble inputs used to report trouble conditions such as module communications problems.

Trouble inputs are used to monitor the module status and in most cases are not physically connected to an external input.

The following table details the trouble inputs that are configured in the system and the trouble groups that they are associated with.

Input Number	Description	Default Trouble Group	Default Trouble Group Option
RDxxx:01-11	Reserved	None	None
RDxxx:12	Reader 1 Tamper	System	System Tamper
RDxxx:13	Reader 2 Tamper	System	System Tamper
RDxxx:14	Door 1 Lockout	Access	Too Many Attempts
RDxxx:15	Door 2 Lockout	Access	Too Many Attempts
RDxxx:16	Module Offline	System	Module Offline

Replace 'xxx' with the address of the module that you are programming.

Door Trouble Inputs

In addition to the trouble inputs of the module itself, the reader expander can also monitor trouble inputs associated with connected doors. These are used for monitoring and reporting door troubles such as door forced and duress conditions.

Input Number	Description	Default Trouble Group	Default Trouble Group Option
Door xxx 01	Door Forced	Access	Forced Door
Door xxx 02	Door Left Open	Access	Left Open
Door xxx 08	Door Duress	None	None

'xxx' refers to the **Name** of the door in the Protege system.

Outputs

The reader expander has 8 programmable outputs. These outputs are used to activate bell sirens, lighting circuits, door locks, relay accessory products and other automation points.

Lock Outputs (1 and 2)

Relays are provided on outputs 1 and 2. These are used for the Lock 1 (Output 1 RD001:01) and Lock 2 (Output 2 RD001:02) functions and are used to control electric door strikes and other lock control devices.

Lock Output 1/2 Connection (Output 1 Shown):

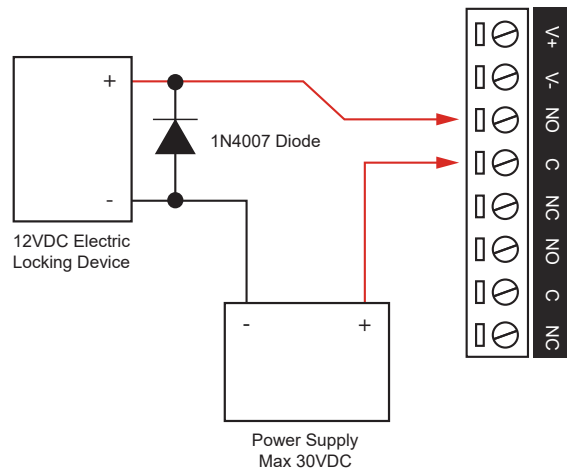

The locking device is connected to the **NO** terminal, as displayed above, for power to unlock / fail secure devices. For power to lock / fail safe devices the locking device is connected to the **NC** terminal.

The 1N4007 diode is supplied for lock output connections and **must** be installed at the electric strike terminals.

Warning: Relay outputs can switch to a maximum capacity of 7A. Exceeding 7A will damage the output.

Standard Outputs (3 To 8)

The outputs 3, 4, 5, 6, 7 and 8 on the reader expander are open collector outputs and switch to a ground connection.

The outputs have a default pre-programmed function as detailed in the following table and are used to control the indicator and audible outputs on the attached reading device. These functions may be disabled by programming the appropriate setting in the reader expander configuration.

Output Number	Description
RDxxx:03	LED 1 (Green) Reader 1
RDxxx:04	LED 2 (Red) Reader 1
RDxxx:05	Beeper Reader 1
RDxxx:06	LED 1 (Green) Reader 2
RDxxx:07	LED 2 (Red) Reader 2
RDxxx:08	Beeper Reader 2

Replace 'xxx' with the address of the module that you are programming.

Example Open Collector Output Connection (LED):

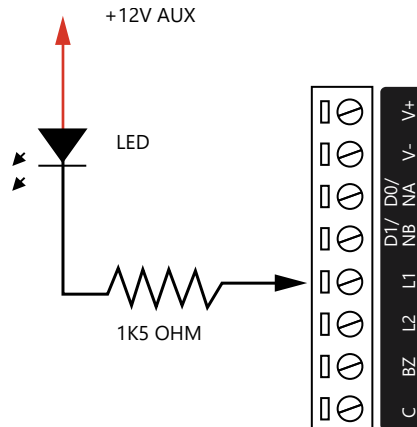

Warning: Outputs 3 to 8 can switch to a maximum capacity of 50mA each. Exceeding this amount will damage the output.

Beeper Outputs (5 and 8)

The beeper outputs 5 and 8 on the reader expander provide diagnostic information to the end user and installer when a card is presented and access is denied or the unit is operating offline. The following table shows the beeper modes of operation.

Function	Description
2 Beeps	Access Granted The lock will activate and allow access to the door at which the card has been presented.
1 Long Beep	Access Denied The card or PIN is not recognized, or the user does not have access to this door.
4 Beeps	Offline Access Granted If the module is operating offline from the controller, the reader generates additional beeps whenever it grants access to a user.

Address Configuration

Protege modules are set to address 254 at the factory. This is above the address range that the controller supports, so the module will not come online immediately when you connect it to the module network.

To bring the module online, you must set the module address to a valid unused address. See the Protege system controller configuration guide for instructions on how to program the address.

You will need the module's serial number to set the address. You can find the serial number on the identification sticker on the product.

LED Indicators

Protege DIN rail modules feature comprehensive diagnostic indicators that can aid the installer in diagnosing faults and conditions. In some cases an indicator may have multiple meanings depending on the status indicator display at the time.

Status Indicator

The status indicator displays the module status.

State	Description
Fast flash (green)	Module attempting registration with controller
Slow flash (green)	Module successfully registered with controller
Flashing (red)	Module communications activity

When the fault and status indicators are flashing alternately, the module is in identification mode, enabling the installer to easily identify the module in question. Upon either a module update or the identification time period expiring, the module will return to normal operation.

Fault Indicator

The fault indicator is lit any time the module is operating in non-standard mode. If the fault indicator is flashing, the module requires a firmware update or is in firmware update mode. When the fault indicator is on, the status indicator will flash an error code.

State	Description
Continuous slow flash (red)	Module is in boot mode awaiting firmware update
Constantly on (red)	Module is in error state and will flash an error code with the status indicator

Power Indicator

The power indicator is lit whenever the correct module input voltage is applied across the N+ and N- terminals.

State	Description
Constantly on (green)	Correct module input voltage applied
Constantly off	Incorrect module input voltage applied

Relay Indicators

The relay indicators show the status of the lock output relays.

State	Description
Constantly on (red)	Relay output is ON
Constantly off	Relay output is OFF

Reader 1/Reader 2 Indicators

The reader 1 and reader 2 indicators display the status of the data being received by the onboard readers.

State	Description
Short Flash (red)	A short flash (<250 Milliseconds) on the reader 1/reader 2 indicators will show that data was received but was not in the correct format.
Long Flash (red)	A long flash (>1 Second) indicates that the unit has read the data and the format was correct.

Input Indicators

Whenever an input on the module is programmed with an input type and area, the input status will be displayed on the front panel indicator corresponding to the physical input number. This allows for easy test verification of inputs without the need to view the inputs from the keypad or the Protege software.

State	Description
Constantly off	Input is not programmed
Constantly on (red)	Input is in an open state
Constantly on (green)	Input is in a closed state
Continuous flash (red)	Input is in a tamper state
Continuous flash (green)	Input is in a short state

Error Code Indication

When the module attempts to register or communicate with the system controller a registration error can be generated indicating that it was not successful.

Error Code Display

The following table is only valid if the **fault** indicator is constantly on and the **status** indicator is flashing red.

If the fault indicator is flashing the module requires a firmware update or is currently in firmware update mode.

The status indicator will flash red with the error code number. The error code number is shown with a 250ms on and off period (duty cycle) with a delay of 1.5 seconds between each display cycle.

Flash	Error Description
1	Unknown Error Code The error code returned by the system controller could not be understood by the module.
2	Firmware Version The firmware version on the module is not compatible with the system controller. To clear this error, update the module using the module update feature in the controller's web interface.
3	Address Too High The module address is above the maximum number available on the system controller. To clear this error change the address to one within the range set on the system controller, restart the module by disconnecting the power.
4	Address In Use The address is already in use by another module. To clear this error set the address to one that is not currently occupied. Use the view network status command to list the attached devices, or the network update command to refresh the registered device list.
5	Controller Secured Registration Not Allowed The controller is not accepting any module registrations. To allow module registrations use the network secure command to change the setting to not secured.
6	Serial Number Fault The serial number in the device is not valid. Return the unit to the distributor for replacement.
7	Locked Device The module or system controller is a locked device and cannot communicate on the network. Return the unit to the distributor for replacement.

Mechanical Diagram

The diagram shown below outlines the essential details needed to help ensure the correct installation of the reader expander.

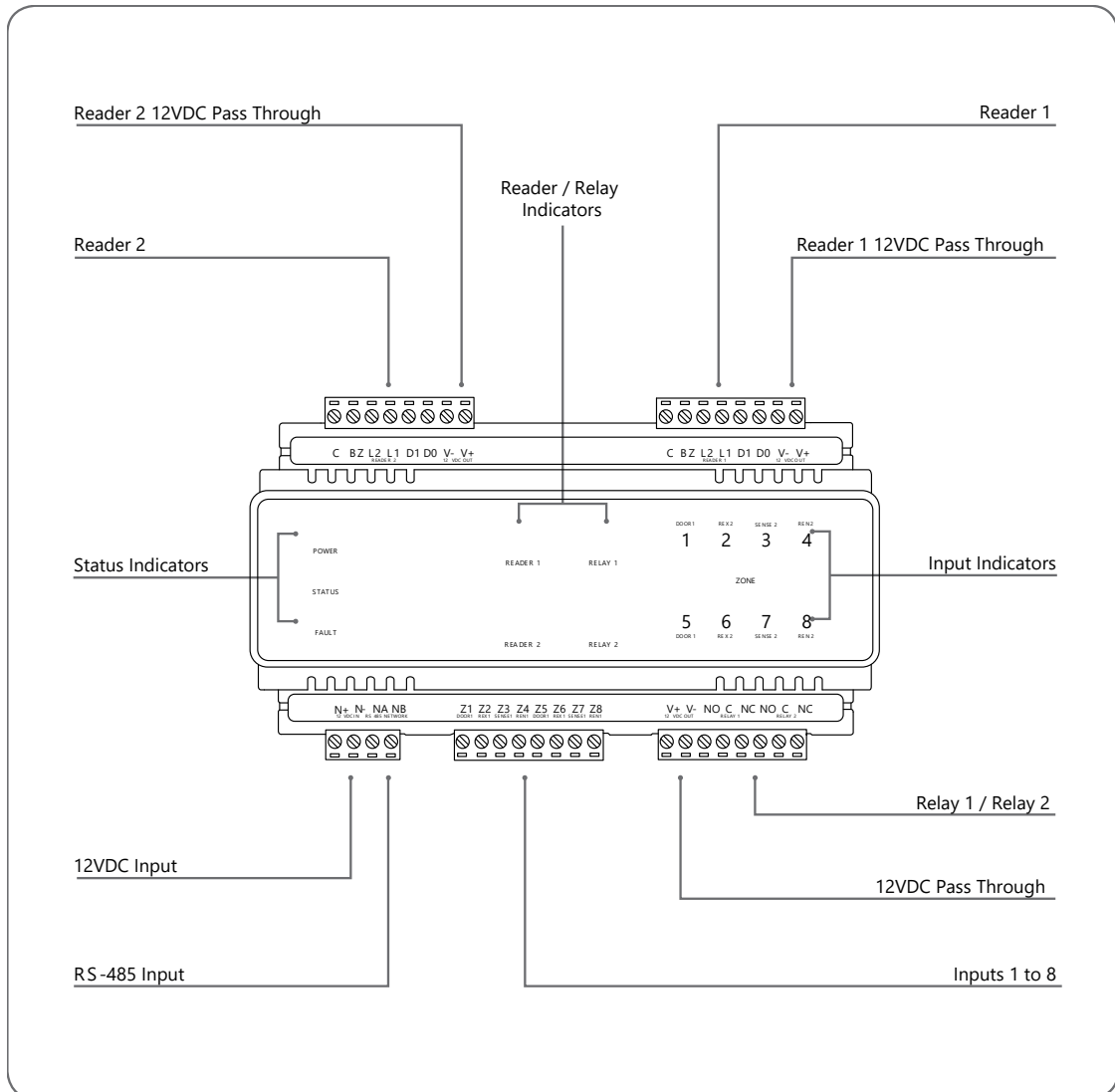

Mechanical Layout

The mechanical layout below outlines the essential details needed to help ensure correct installation and mounting. All measurements are shown in millimeters.

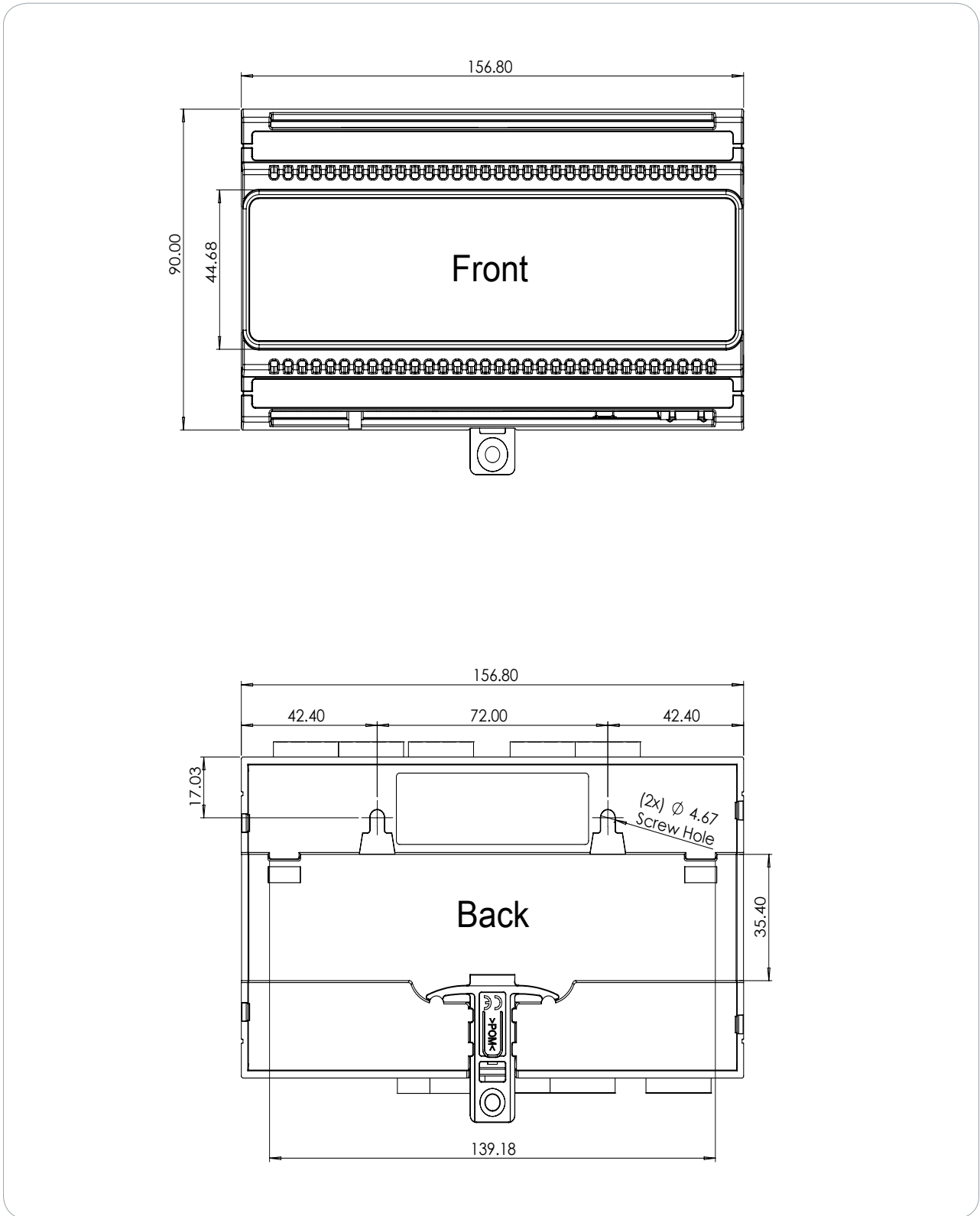

Technical Specifications

The following specifications are important and vital to the correct operation of this product. Failure to adhere to the specifications will result in any warranty or guarantee that was provided becoming null and void.

Ordering Information	
PRT-RDM2-DIN-485	Protege DIN Rail 2 Door Reader Expander
Power Supply	
DC Input Voltage	11-14VDC
DC Output Voltage (DC IN Pass Through)	10.83-14.0VDC 0.7A (Typical) Electronic Shutdown at 1.1A Reader 1&2 10.45-13.85VDC Pass Through share 0.7A (Typical) Electronic Shutdown at 1.1A
Operating Current	80mA (Typical)
Total Combined Current*	1.56A (Max)
Low Voltage Cutout	8.7VDC
Low Voltage Restore	10.5VDC
Communication	
RS-485	Module network
Offline Operation	
Offline Access Modes	All Users, First 10 Users plus 150 Card Cache, No Users
Readers	
Reader Configurations	2 reader ports, independently configurable for either Wiegand (up to 1024 bits configurable) or RS-485, allowing connection of up to 4 readers providing entry/exit control for two doors **
	RS-485 reader port connections support configuration for OSDP protocol
Outputs	
Lock Outputs	2 Form C Relay Outputs - 7A N.O/N.C. at 30 VAC/DC resistive/inductive
Outputs	6 (50mA Max) Open Collector
Inputs	
Inputs	8 High Security Monitored Inputs (10ms to 1hr Input Speed Programmable)
Trouble Inputs	16
Dimensions	
Dimensions (L x W x H)	157 x 90 x 60mm (6.2 x 3.5 x 2.4")
Net Weight	300g (10.6oz)
Gross Weight	370g (13.1oz)
Operating Conditions	
Operating Temperature	UL/cUL 0° to 49°C (32° to 120°F) : EU EN -10° to 55°C (14° to 131°F)
Storage Temperature	-10° to 85°C (14° to 185°F)

Humidity	0%-93% non-condensing, indoor use only (relative humidity)
Mean Time Between Failures (MTBF)	622,997 hours (calculated using RDF 2000 (UTE C 80-810) Standard)

* The total combined current refers to the current that will be drawn from the external power supply to supply the expander and any devices connected to its outputs. The auxiliary outputs are directly connected via thermal resettable fuses to the N+ N- input terminals, and the maximum current is governed by the trip level of these fuses.

** Each reader port supports either Wiegand or RS-485 reader operation, but not both at the same time. If combining reader technologies, they must be connected on separate ports.

It is important that the unit is installed in a dry cool location that is not affected by humidity. Do not locate the unit in air conditioning or a boiler room that can exceed the temperature or humidity specifications.

Integrated Control Technology continually strives to increase the performance of its products. As a result these specifications may change without notice. We recommend consulting our website (www.ict.co) for the latest documentation and product information.

New Zealand and Australia

General Product Statement

The RCM compliance label indicates that the supplier of the device asserts that it complies with all applicable standards.



ASIAL Class 5

This product is certified for AS/NZS 2201:2007 Class 5 installations as part of a compliant Protege GX or Protege WX system.

For more information, see the Protege GX / Protege WX AS/NZS 2201.1:2007 Class 5 Compliance Installer Guide, available from ICT.

European Standards

CE Statement

Conforms where applicable to European Union (EU) Low Voltage Directive (LVD) 2014/35/EU, Electromagnetic Compatibility (EMC) Directive 2014/30/EU, Radio Equipment Directive (RED) 2014/53/EU and RoHS Recast (RoHS2) Directive: 2011/65/EU + Amendment Directive (EU) 2015/863.

This equipment complies with the rules, of the Official Journal of the European Union, for governing the Self Declaration of the CE Marking for the European Union as specified in the above directive(s).



Information on Disposal for Users of Waste Electrical & Electronic Equipment

This symbol on the product(s) and / or accompanying documents means that used electrical and electronic products should not be mixed with general household waste. For proper treatment, recovery and recycling, please take this product(s) to designated collection points where it will be accepted free of charge.

Alternatively, in some countries you may be able to return your products to your local retailer upon purchase of an equivalent new product.

Disposing of this product correctly will help save valuable resources and prevent any potential negative effects on human health and the environment, which could otherwise arise from inappropriate waste handling.

Please contact your local authority for further details of your nearest designated collection point.

Penalties may be applicable for incorrect disposal of this waste, in accordance with your national legislation.

For business users in the European Union

If you wish to discard electrical and electronic equipment, please contact your dealer or supplier for further information.

Information on Disposal in other Countries outside the European Union

This symbol is only valid in the European Union. If you wish to discard this product please contact your local authorities or dealer and ask for the correct method of disposal.

EN50131 Standards

This component meets the requirements and conditions for full compliance with EN50131 series of standards for equipment classification.

EN 50131-1:2006+A2:2017, EN 50131-3:2009, EN 50131-6:2008+A1:2014, EN 50131-10:2014, EN 50136-1:2012, EN 50136-2:2013, EN 60839-11-1:2013

Security Grade 4

Environmental Class II

Equipment Class: Fixed

Readers Environmental Class: IVA, IK07

SP1 (PSTN – voice protocol)

SP2 (PSTN – digital protocol)

SP6 (LAN – Ethernet) and DP1 (LAN – Ethernet + PSTN)

SP6 (LAN – Ethernet) and DP1 (LAN – Ethernet + USB-4G modem)

Tests EMC (operational) according to EN 55032:2015

Radiated disturbance EN 55032:2015

Power frequency magnetic field immunity tests (EN 61000-4-8)

EN50131

In order to comply with EN 50131-1 the following points should be noted:

- Ensure for Grade 3 or 4 compliant systems, the minimum PIN length is set for 6 digits.
- To comply with EN 50131-1 Engineer access must first be authorized by a user, therefore Installer codes will only be accepted when the system is unset. If additional restriction is required then Engineer access may be time limited to the first 30 seconds after the system is unset.
- Reporting delay –Violation off the entry path during the entry delay countdown will trigger a warning alarm. The warning alarm should not cause a main alarm signal and is not reported at this time. It can be signaled locally, visually and or by internal siren type. If the area is not disarmed within 30 seconds, the entry delay has expired or another instant input is violated, the main alarm will be triggered and reported.
- To comply with EN 50131-1 neither Internals Only on Part Set Input Alarm nor Internals Only on Part Set Tamper Alarm should be selected.
- To comply with EN 50131-1 Single Button Setting should not be selected.
- To comply with EN 50131-1, only one battery can be connected and monitored per system. If more capacity is required, a single larger battery must be used.
- For Security Grade 4 installations, two forms of reporting are required. This can be satisfied using the onboard 2400bps modem included with the modem controller model, or through the incorporation of the PRT-4G-USB cellular modem module into the installation with the non-modem controller model.

Anti Masking

To comply with EN 50131-1 Grade 3 or 4 for Anti Masking, detectors with a separate or independent mask signal should be used and the mask output should be connected to another input.

I.e. Use 2 inputs per detector. One input for alarm/tamper and one input for masking.

To comply with EN 50131-1:

- Do not fit more than 10 unpowered detectors per input,
- Do not fit more than one non-latching powered detector per input,
- Do not mix unpowered detectors and non-latching powered detectors on an input.

To comply with EN 50131-1 the Entry Timer should not be programmed to more than 45 seconds.

To comply with EN 50131-1 the Bell Cut-Off Time should be programmed between 02 and 15 minutes.

EN 50131-1 requires that detector activation LEDs shall only be enabled during Walk Test. This is most conveniently achieved by using detectors with a Remote LED Disable input.

To comply with EN 50131-1, EN 60839-11 Security Grade 4 and AS/NZS2201.1 class 4&5 Vibration Detection for PreTamper Alarm, protection is provided by a DSC SS-102 Shockgard Seismic vibration sensor mounted within the system enclosure. Alarm output is provided by a pair of non-latching, N.C. (normally closed) relay contacts, opening for a minimum of 1 second on detection of an alarm connected in series with the 24Hr tamper input (TP) on the PSU (or any other system input designated/programmed as a 24Hr Tamper Alarm).

This relay is normally energized to give fail-safe operation in the event of a power loss. Indication of detection is provided by a LED situated on the front cover. The vibration sensor is fully protected from tampering by a N.C. micro switch operated by removal of the cover.

Enclosure EN-DIN-24 has been tested and certified to EN50131.

By design, the enclosures for all Integrated Control Technology products, EN-DIN-11, EN-DIN-12 and EN-DIN-24-ATTACK, comply with the EN 50131 standards. Tamper protection against removal of the cover as well as removal from mounting is provided by tamper switch.

Warning: Enclosures supplied by 3rd parties may not be EN50131-compliant, and should not be claimed as such.

UK Conformity Assessment Mark

General Product Statement

The UKCA Compliance Label indicates that the supplier of the device asserts that it complies with all applicable standards.



UL and cUL Installation Requirements

Only UL / cUL listed compatible products are intended to be connected to a UL / cUL listed control system.

UL/cUL Enclosures

All UL/cUL installations must use an enclosure (cabinet) that is listed to the relevant UL or cUL standard.

ICT offers a range of UL- and cUL-listed enclosures that are suitable for installation of Protege DIN rail products and accessories such as batteries. For our enclosure listings, see one of the following locations:

- The UL/cUL-Listed Protege Enclosures reference document, available from the ICT website.
- [UL Product iQ](#)

cUL Compliance Requirements

CAN/ULC-60839-11-1

- The Protege controller and reader expander module are intended to be mounted within the enclosure (refer to UL/cUL Installation Cabinet Options), installed inside the protected premise, and are CAN/ULC-60839-11-1 Listed for Class I applications only.
- Exit devices and wiring must be installed within the protected area.
- For the Protege controller and reader expander module, all RS-485 and reader terminal connections must be made using shielded grounded cable.
- All readers must be connected with shielded, grounded cable.
- A bell or visual indicator used as an arming acknowledgment signal must be listed to a cUL security, signaling or fire standard. If intended to be mounted outside, it must be rated for outdoor use.
- Fail secure locking mechanisms shall only be installed where allowed by the local authority having jurisdiction (AHJ) and shall not impair the operation of panic hardware and emergency egress.
- If fire resistance is required for door assembly, portal locking device(s) must be evaluated to ULC-S533 and CAN/ULC-S104.
- Must be installed with CAN/ULC-60839-11-1 listed portal locking device(s) for cUL installations.
- If a flexible cord is used to connect to line voltage, strain relief must be provided for the cord inside the enclosure or at the knockout.
- The power supply is not intended to be mounted on the exterior of vault, safe, or stockroom.

CAN/ULC-S319

- The Protege controller and reader expander module are intended to be mounted within the enclosure (refer to UL/cUL Installation Cabinet Options), installed inside the protected premise, and are CAN/ULC-S319 Listed for Class I applications only.
- Exit devices and wiring must be installed within the protected area.
- For the Protege controller and reader expander module, all RS-485 and reader terminal connections must be made using shielded grounded cable.
- All readers must be connected with shielded, grounded cable.
- A bell or visual indicator used as an arming acknowledgment signal must be listed to a cUL security, signaling or fire standard. If intended to be mounted outside, it must be rated for outdoor use.
- Fail secure locking mechanisms shall only be installed where allowed by the local authority having jurisdiction (AHJ) and shall not impair the operation of panic hardware and emergency egress.
- If fire resistance is required for door assembly, portal locking device(s) must be evaluated to ULC-S533 and CAN/ULC-S104.

- Must be installed with CAN/ULC-S319 listed portal locking device(s) for cUL installations.
- If a flexible cord is used to connect to line voltage, strain relief must be provided for the cord inside the enclosure or at the knockout.
- The power supply is not intended to be mounted on the exterior of vault, safe, or stockroom.

UL Compliance Requirements

UL294

- The Protege controller and reader expander module are intended to be mounted within the enclosure (refer to UL/cUL Installation Cabinet Options), installed inside the protected premise, and are UL 294 Listed for Attack Class I applications only.
- Exit devices and wiring must be installed within the protected area.
- For the Protege controller and reader expander module, all RS485 and reader terminal connections must be made using shielded grounded cable.
- All readers must be connected with shielded, grounded cable.
- A bell or visual indicator used as an arming acknowledgment signal must be listed to a UL security, signaling or fire standard. If intended to be mounted outside, it must be rated for outdoor use.
- Fail secure locking mechanism shall only be installed where allowed by the local authority having jurisdiction (AHJ) and shall not impair the operation of panic hardware and emergency egress.
- If fire resistance is required for door assembly, portal locking device(s) must be evaluated to UL10B or UL10C.
- Must be installed with UL 1034 listed electronic locks for UL installations.
- AC power on shall be indicated by an external panel mount LED (Lumex SSI-LXH312GD-150) and fitted into a dedicated 4mm hole in the cabinet to provide external visibility. This shall be wired between 12V and a PGM output that is programmed to follow the AC trouble input as shown below:

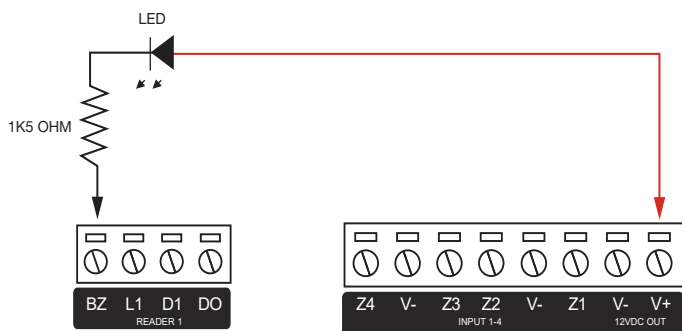

- If a flexible cord is used to connect to line voltage, strain relief must be provided for the cord inside the enclosure or at the knockout.
- The power supply is not intended to be mounted on the exterior of vault, safe, or stockroom.

Performance Levels

	Destructive Attack	Line Security	Endurance	Standby Power
PRT-RDM2-DIN-485	Level I	Level I	Level IV	Level I

FCC Compliance Statements

FCC Rules and Regulations CFR 47, Part 15, Subpart B

This equipment complies with the limits for a Class A digital device, pursuant to Part 15 of the FCC rules.

Operation is subject to the following two conditions:

- This device may not cause harmful interference.
- This device must accept any interference received, including interference that may cause undesired operation.

NOTE: THE GRANTEE IS NOT RESPONSIBLE FOR ANY CHANGES OR MODIFICATIONS NOT EXPRESSLY APPROVED BY THE PARTY RESPONSIBLE FOR COMPLIANCE. SUCH MODIFICATIONS COULD VOID THE USER'S AUTHORITY TO OPERATE THE EQUIPMENT.

Industry Canada Statement

ICES-003

This class A digital apparatus complies with Canadian ICES-003.

Cet appareil numérique de la classe A est conforme à la norme NMB-003 du Canada.

CAN ICES-3 (A)/NMB-3(A)

Disclaimer and Warranty

Disclaimer: Whilst every effort has been made to ensure accuracy in the representation of this product, neither Integrated Control Technology Ltd nor its employees shall be liable under any circumstances to any party in respect of decisions or actions they may make as a result of using this information. In accordance with the ICT policy of enhanced development, design and specifications are subject to change without notice.

For warranty information, see our [Standard Product Warranty](#).

Designers & manufacturers of integrated electronic access control, security and automation products.
Designed & manufactured by Integrated Control Technology Ltd.
Copyright © Integrated Control Technology Limited 2003-2026. All rights reserved.

Disclaimer: Whilst every effort has been made to ensure accuracy in the representation of this product, neither Integrated Control Technology Ltd nor its employees shall be liable under any circumstances to any party in respect of decisions or actions they may make as a result of using this information. In accordance with the ICT policy of enhanced development, design and specifications are subject to change without notice.