



**PRT-HZX16-DIN**

# **Protege Half DIN Rail 16 Input Expander**

Installation Manual



The specifications and descriptions of products and services contained in this document were correct at the time of printing. Integrated Control Technology Limited reserves the right to change specifications or withdraw products without notice. No part of this document may be reproduced, photocopied, or transmitted in any form or by any means (electronic or mechanical), for any purpose, without the express written permission of Integrated Control Technology Limited. Designed and manufactured by Integrated Control Technology Limited, Protege® and the Protege® Logo are registered trademarks of Integrated Control Technology Limited. All other brand or product names are trademarks or registered trademarks of their respective holders.

Copyright © Integrated Control Technology Limited 2003-2026. All rights reserved.

Last Published: 20-Jan-26 2:01 PM

# Contents

<b>Introduction</b>	<b>5</b>
<b>Installation Requirements</b>	<b>6</b>
Wiring	6
Dual Stack Connectors	6
<b>Grounding Requirements</b>	<b>7</b>
Safety Grounding	7
Earth Ground Connection	7
<b>Mounting</b>	<b>9</b>
Removal	9
<b>Wiring Diagram</b>	<b>10</b>
<b>DC Power &amp; Encrypted Module Network</b>	<b>11</b>
End-of-Line (EOL) Resistors	11
<b>Inputs</b>	<b>12</b>
Trouble Inputs	13
<b>Address Configuration</b>	<b>14</b>
<b>LED Indicators</b>	<b>15</b>
Status Indicator	15
Fault Indicator	15
Power Indicator	15
Input Indicators	16
<b>Error Code Indication</b>	<b>17</b>
Error Code Display	17
<b>Mechanical Diagram</b>	<b>18</b>
<b>Mechanical Layout</b>	<b>19</b>
<b>Technical Specifications</b>	<b>20</b>
<b>New Zealand and Australia</b>	<b>21</b>
<b>European Standards</b>	<b>22</b>
<b>UK Conformity Assessment Mark</b>	<b>24</b>
<b>UL and cUL Installation Requirements</b>	<b>25</b>
UL/cUL Enclosures	25
Central Station Signal Receiver Compatibility List	25
cUL Compliance Requirements	25
CAN/ULC-S304	25

CAN/ULC-S559 .....	28
UL Compliance Requirements .....	31
UL1610 .....	31
<b>FCC Compliance Statements .....</b>	<b>34</b>
<b>Industry Canada Statement .....</b>	<b>35</b>
<b>Disclaimer and Warranty .....</b>	<b>36</b>

# Introduction

---

The Protege Half DIN Rail 16 Input Expander extends the number of inputs on the system by 16, allowing monitoring of a wide range of EOL capable or open contact sensors for security and building automation purposes.

Flexible module network architecture allows large numbers of modules to be connected to the RS-485 module network. Up to 250 modules can be connected to the Protege system in any combination to the network, over a distance of up to 900M (3000ft). Further span can be achieved with the use of a network repeater module.

The current features of the input expander include:

- Secure encrypted RS-485 module communications
- 16 inputs
- Industry standard DIN rail mounting
- Online and remote upgradable firmware

# Installation Requirements

---

This equipment is to be installed in accordance with:

- The product installation instructions
- UL 294 - Access Control System Units
- UL 681 - Installation and Classification of Burglar and Holdup Systems
- UL 827 - Central-Station Alarm Services
- CAN/ULC-S301, Central and Monitoring Station Burglar Alarm Systems
- CAN/ULC-S302, Installation and Classification of Burglar Alarm Systems for Financial and Commercial Premises, Safes and Vaults
- CAN/ULC-S561, Installation and Services for Fire Signal Receiving Centres and Systems
- CAN/ULC-60839-11-1, Alarm and Electronic Security Systems – Part 11-1: Electronic Access Control Systems – System and Components Requirements
- The National Electrical Code, ANSI/NFPA 70
- The Canadian Electrical Code, Part I, CSA C22.1
- The Local Authority Having Jurisdiction (AHJ)

## Wiring



For UL/cUL installations, the following wiring specifications must be observed.

**Input Wiring:** Maximum distance of 300m (1000ft) from the connected module when using 22 AWG.

**Aux Wiring:** Minimum 22AWG, maximum 16AWG (depends on length and current consumption).

For wire/cable size, a maximum of 5% voltage drop at the terminals of the powered device must be observed.

### Module Network Wiring:

- Minimum 24AWG (0.51mm) shielded twisted pair with characteristic impedance of 120Ω. Maximum length 900m (3000ft).
- CAT5e / CAT6 also supported for data transmission when using ground in the same cable. Maximum length 100m (330 ft).

Do not use extra wires in the cable to power devices.

## Dual Stack Connectors

This half DIN rail product employs an economical dual stack design which accommodates a double layer PCB with two rows of connectors. This requires the use of a specific connector configuration in which the design of the upper connectors is slightly different to the lower connectors. Pin positions on one row are incompatible with the connections on the other, and swapping upper and lower connectors may damage the connectors and the PCB.

Please check carefully before inserting connectors as incorrect placement can cause damage to the PCB.

# Grounding Requirements

---

An effectively grounded product is one that is intentionally connected to earth ground through a ground connection or connections of sufficiently low impedance and having sufficient current-carrying capacity to prevent elevated voltages that may result in undue hazard to connected equipment or to persons.

Grounding of the Protege system is done for three basic reasons:

1. Safety
2. Component protection
3. Noise reduction

## Safety Grounding

The object of safety grounding is to ensure that all metalwork is at the same ground (or earth) potential. Impedance between the Protege system and the building scheme ground must conform to the requirements of national and local industrial safety regulations or electrical codes. These will vary based on country, type of distribution system and other factors. The integrity of all ground connections should be checked periodically.

General safety dictates that all metal parts are connected to earth with separate copper wire or wires of the appropriate gauge.

**Warning:** All cabinet internal covers and lids/doors must be connected to the cabinet's main ground point for electrical safety and static discharge protection.

## Earth Ground Connection

The DIN rail enclosure and the DIN rail modules must be grounded to a suitable single-point earth ground connection in the installation. A minimum 14AWG solid copper wire (or thicker, in accordance with local authorities) shall be used from the Protege system's earth connection points.

The DIN rail enclosure includes an earth ground single-point link connection via the metallic enclosure. This single-point link is the Protege system's earth ground. All modules that have earth ground connections and that are installed in the same enclosure shall be connected to this single point. A single-point earth ground connection avoids the creation of ground loops in the system and provides a single reference point to earth ground.

DIN Rail Ground Connections (one or more cabinets installed in the same room)

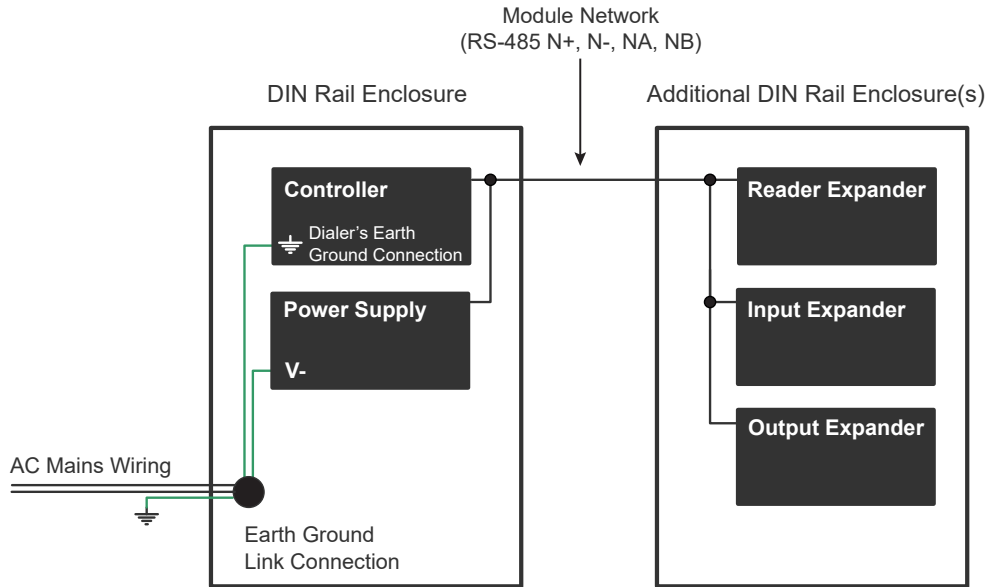

DIN Rail Ground Connections (multiple cabinets in different rooms, sectors, or buildings)

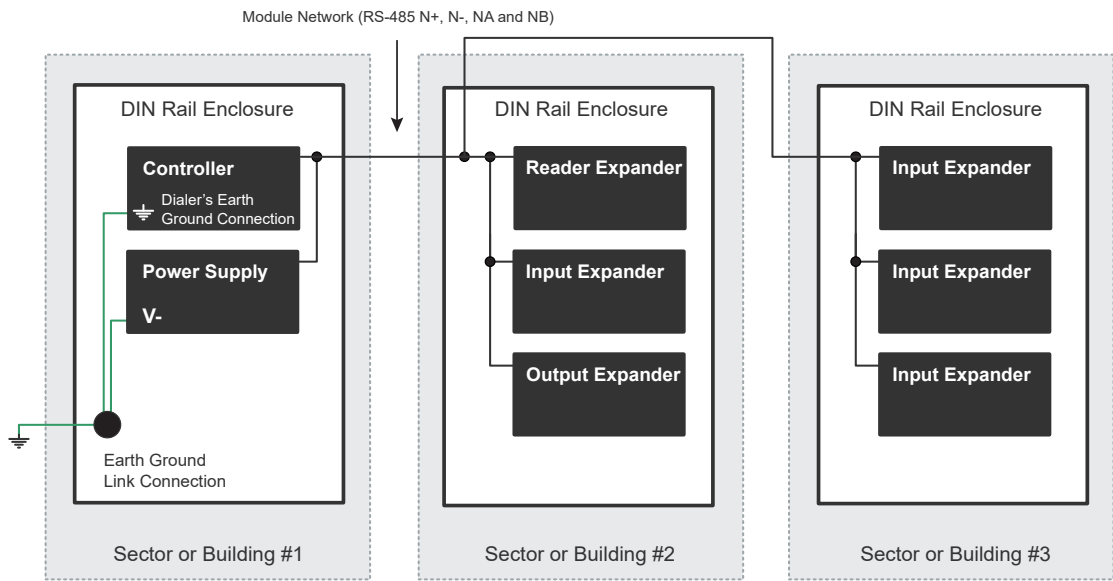

The Dialer's Earth Ground Connection applies to modem model controllers only.

Note that the DIN rail enclosure earth terminal is connected to the power supply V- terminal.

There must be only **one** single earth grounding point per system.

# Mounting

---

Protege half DIN rail modules are designed to mount on standard DIN rail, either in dedicated DIN cabinets or on generic DIN rail mounting strip.

They can also be hung from the top mount screw and permanently fastened using the hole in the attachment clip.

## Location

Protege DIN rail modules must be installed indoors, within the protected area. Modules must be protected by a secure cabinet with tamper detection.

We recommend installing the cabinet in a location that provides easy access for wiring. Suitable locations include electrical rooms, communication equipment rooms and accessible areas of the ceiling. Ensure that there is adequate clearance around each device and that air flow to the vents is not restricted.

Protege DIN rail modules must not be installed outdoors. Ensure that the room does not exceed or fall below the operating temperature or humidity ranges listed in the [Technical Specifications](#) for each module. Do not mount cabinets on the exterior of a vault, safe or stockroom.



For UL/cUL installations, you must use a UL- or cUL-listed cabinet. See [UL/cUL Enclosures](#) for the listed cabinets provided by ICT.

## Mounting a DIN Rail Module

To mount a module onto DIN rail:

1. Position the module with the labeling in the correct orientation.
2. Hook the mounting tabs (opposite the tab clip) under the edge of the DIN rail.
3. Push the DIN rail module against the mount until the tab clips over the rail.

## Removal

To remove the DIN rail module from the DIN rail mount:

1. Insert a flat-blade screwdriver into the slot in the module tab clip.
2. Lever the tab outwards and rotate the unit off the DIN rail mount.

# Wiring Diagram

**Notice:** Incorrect wiring may result in damage to the unit.

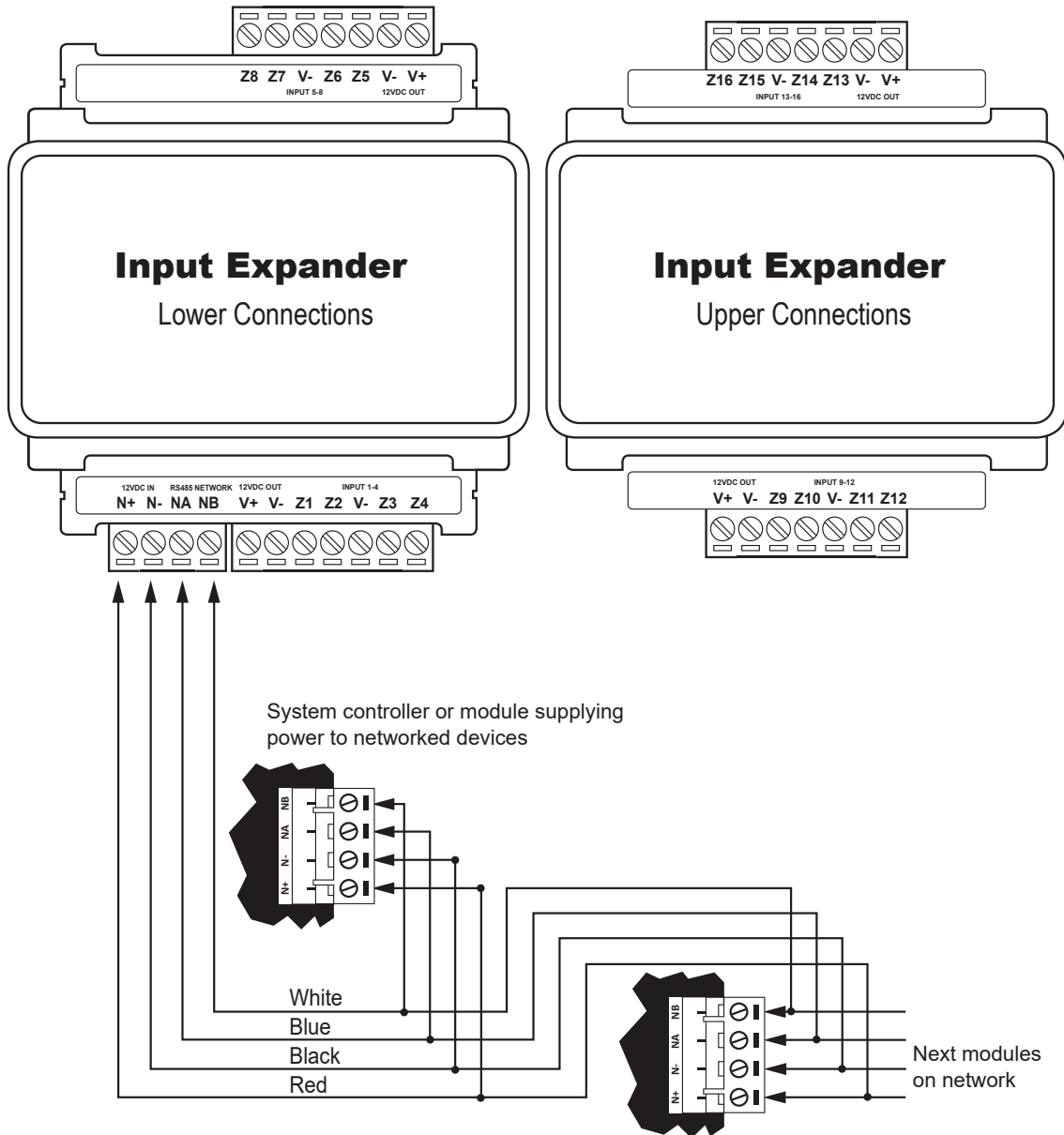

# DC Power & Encrypted Module Network

The expander incorporates encrypted RS-485 communications technology, and both module and network power are supplied by the N+ and N- terminals.

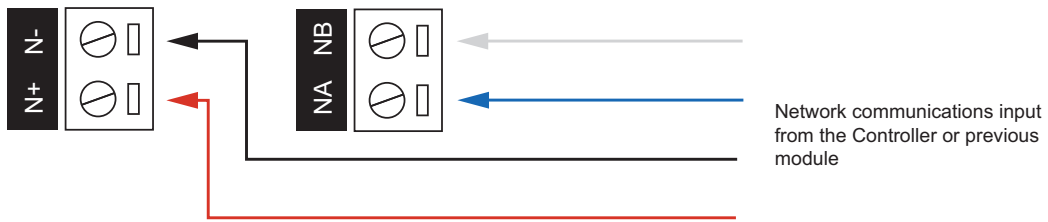

Connection of the communications and DC supply should be performed according to the diagram shown above. It is important that the N+ network communications power be 12VDC supplied from an independent battery backed power supply unit capable of supplying the required voltage to all devices on the RS-485 network.

**Warning:** The 12V N+ and N- communication input must be supplied from only **one** point. Connections from more than one 12V supply may cause failure or damage to the unit or the device supplying network power.

## End-of-Line (EOL) Resistors

End-of-line resistors prevent signal reflections at the ends of the RS-485 network bus, improving signal strength and reducing data corruption.

You must insert a **120Ω resistor** between the NA and NB terminals of the **first** and **last** modules on the RS-485 network. These are the modules physically located at the ends of the RS-485 network cabling.

First Module on RS-485 Network

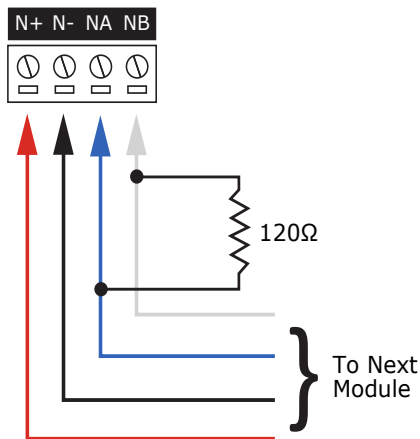

Last Module on RS-485 Network

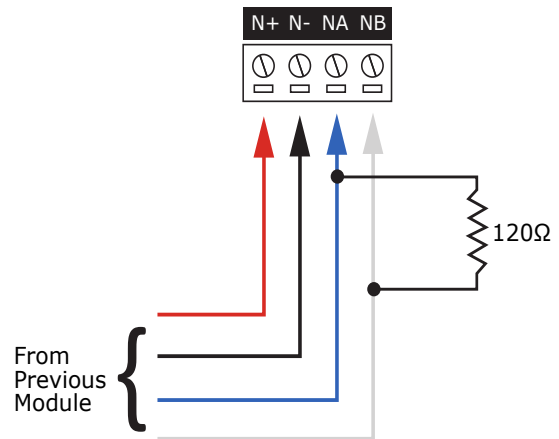

# Inputs

The input expander can monitor the state of up to 16 inputs.



- Magnetic contacts should be listed to UL 634 to comply with UL installation standards and ULC/ORD-C634 to comply with cUL installation standards.
- Motion detectors and temperature sensors should be listed to UL 639 to comply with UL installation standards and ULC-S306 to comply with cUL installation standards.
- The Protege input expander has been evaluated for UL 1610, UL 1635, CAN/ULC-S304 and CAN/ULC-S559.

When using an input with the EOL resistor configuration, the controller generates an alarm condition when the state of an input changes between open and closed and generates a tamper alarm condition when a wire fault (short circuit) or a cut wire (tampered) in the line occurs.

When using the EOL resistor configuration, the EOL resistor option must be enabled in the input programming so that the tamper and short states can be monitored. For more information, refer to your Protege programming reference manual.

## EOL Resistor Input Configuration

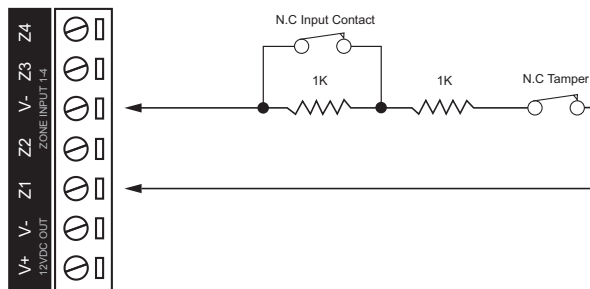

Each input can use a different input configuration. To program a large number of inputs with the same configuration use the multiple selection feature within the Protege software.

When using the 'No Resistor' configuration the controller only monitors the opened and closed state of the connected input device, generating the alarm (open) and restore (closed/sealed) conditions.

## No EOL Resistor Input Configuration

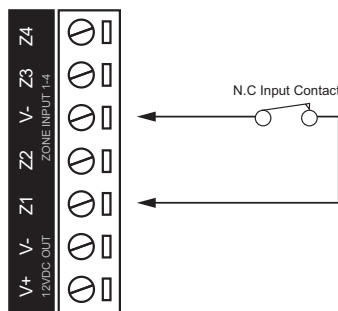

## Trouble Inputs

Each input expander can monitor up to 16 trouble inputs.

Trouble inputs are used to monitor the module status and in most cases are not physically connected to an external input.

The following table details the trouble inputs that are configured in the system and the trouble groups that they are associated with.

Input Number	Description	Default Trouble Group	Default Trouble Group Option
IXxx:01-15	Reserved	None	None
IXxx:16	Module Offline	System	Module Offline

Replace 'xxx' with the address of the module that you are programming.

# Address Configuration

---

Protege modules are set to address 254 at the factory. This is above the address range that the controller supports, so the module will not come online immediately when you connect it to the module network.

To bring the module online, you must set the module address to a valid unused address. See the Protege system controller configuration guide for instructions on how to program the address.

You will need the module's serial number to set the address. You can find the serial number on the identification sticker on the product.

# LED Indicators

---

Protege DIN rail modules feature comprehensive diagnostic indicators that can aid the installer in diagnosing faults and conditions. In some cases an indicator may have multiple meanings depending on the status indicator display at the time.

## Status Indicator

The status indicator displays the module status.

State	Description
Fast flash (green)	Module attempting registration with controller
Slow flash (green)	Module successfully registered with controller
Flashing (red)	Module communications activity

When the fault and status indicators are flashing alternately, the module is in identification mode, enabling the installer to easily identify the module in question. Upon either a module update or the identification time period expiring, the module will return to normal operation.

## Fault Indicator

The fault indicator is lit any time the module is operating in non-standard mode. If the fault indicator is flashing, the module requires a firmware update or is in firmware update mode. When the fault indicator is on, the status indicator will flash an error code.

State	Description
Continuous slow flash (red)	Module is in boot mode awaiting firmware update
Constantly on (red)	Module is in error state and will flash an error code with the status indicator

## Power Indicator

The power indicator is lit whenever the correct module input voltage is applied across the N+ and N- terminals.

State	Description
Constantly on (green)	Correct module input voltage applied
Constantly off	Incorrect module input voltage applied

## Input Indicators

Whenever an input on the module is programmed with an input type and area, the input status will be displayed on the front panel indicator corresponding to the physical input number. This allows for easy test verification of inputs without the need to view the inputs from the keypad or the Protege software.

State	Description
Constantly off	Input is not programmed
Constantly on (red)	Input is in an open state
Constantly on (green)	Input is in a closed state
Continuous flash (red)	Input is in a tamper state
Continuous flash (green)	Input is in a short state

# Error Code Indication

---

When the module attempts to register or communicate with the system controller a registration error can be generated indicating that it was not successful.

## Error Code Display

The following table is only valid if the **fault** indicator is constantly on and the **status** indicator is flashing red.

If the fault indicator is flashing the module requires a firmware update or is currently in firmware update mode.

The status indicator will flash red with the error code number. The error code number is shown with a 250ms on and off period (duty cycle) with a delay of 1.5 seconds between each display cycle.

Flash	Error Description
1	<b>Unknown Error Code</b> The error code returned by the system controller could not be understood by the module.
2	<b>Firmware Version</b> The firmware version on the module is not compatible with the system controller. To clear this error, update the module using the module update feature in the controller's web interface.
3	<b>Address Too High</b> The module address is above the maximum number available on the system controller. To clear this error change the address to one within the range set on the system controller, restart the module by disconnecting the power.
4	<b>Address In Use</b> The address is already in use by another module. To clear this error set the address to one that is not currently occupied. Use the view network status command to list the attached devices, or the network update command to refresh the registered device list.
5	<b>Controller Secured Registration Not Allowed</b> The controller is not accepting any module registrations. To allow module registrations use the network secure command to change the setting to not secured.
6	<b>Serial Number Fault</b> The serial number in the device is not valid. Return the unit to the distributor for replacement.
7	<b>Locked Device</b> The module or system controller is a locked device and cannot communicate on the network. Return the unit to the distributor for replacement.

# Mechanical Diagram

The mechanical diagram shown below outlines the essential details needed to help ensure the correct installation of the input expander.

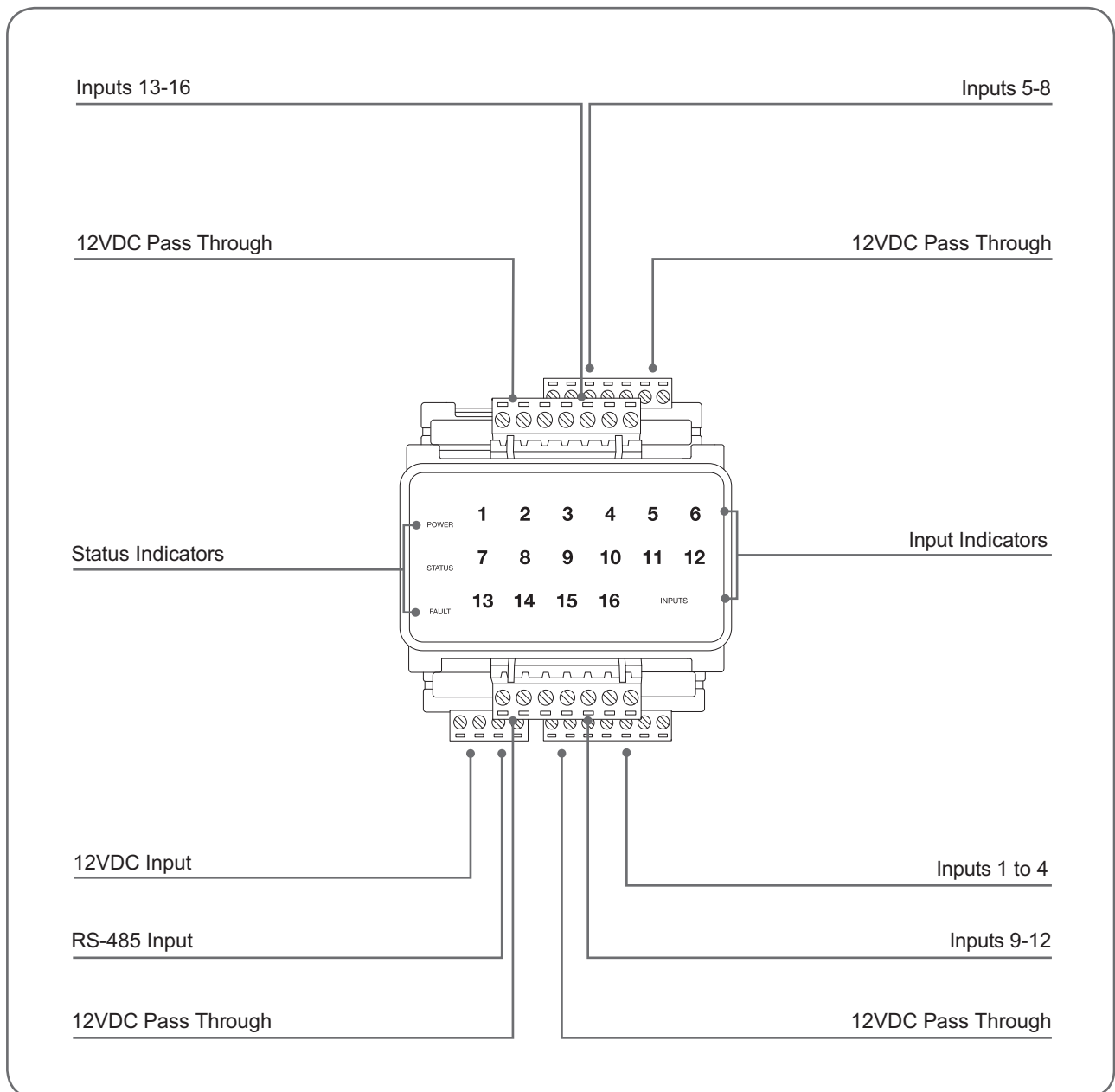

# Mechanical Layout

The mechanical layout shown below outlines the essential details needed to help ensure correct installation and mounting. All measurements are shown in millimeters.

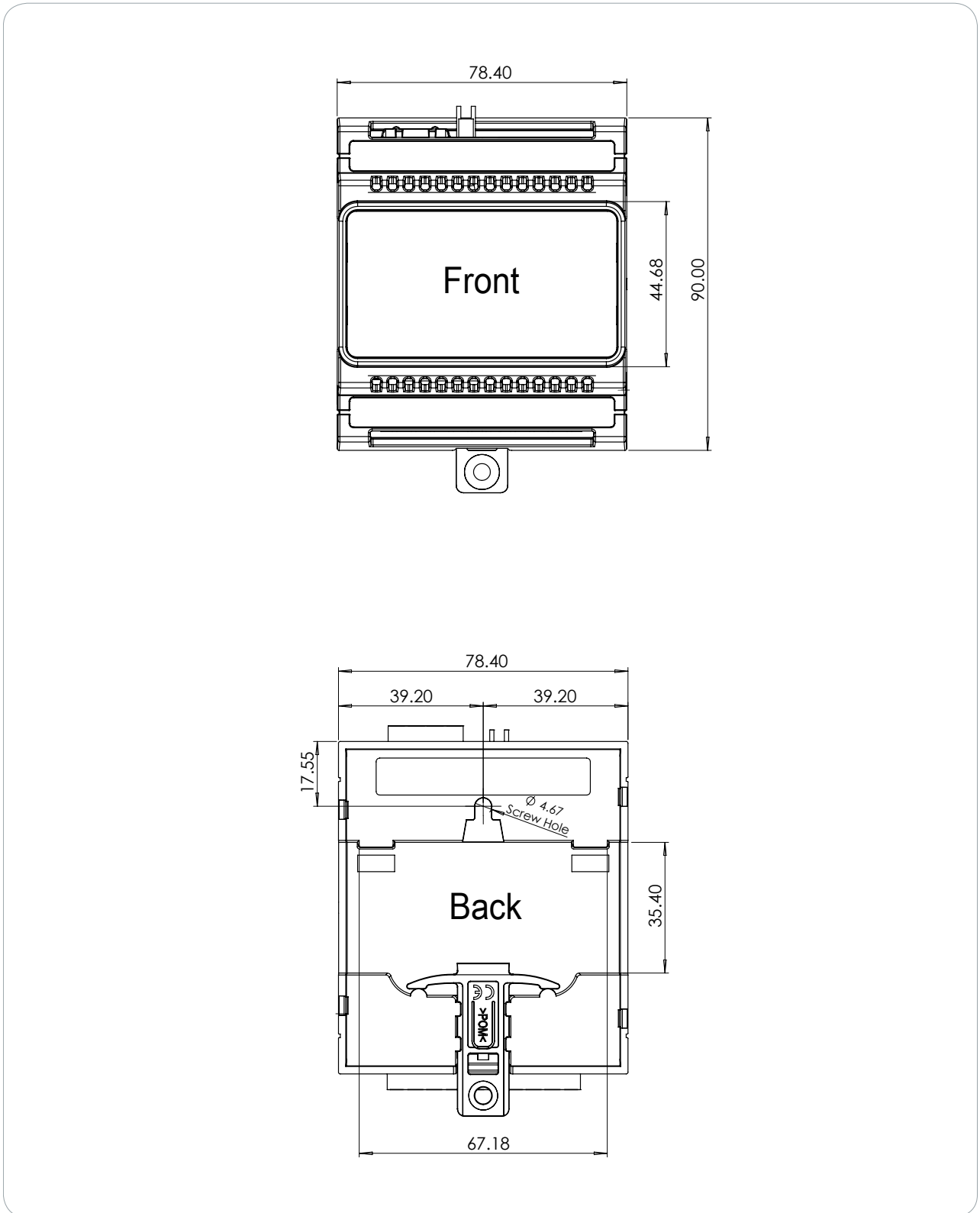

# Technical Specifications

The following specifications are important and vital to the correct operation of this product. Failure to adhere to the specifications will result in any warranty or guarantee that was provided becoming null and void.

Ordering Information	
PRT-HZX16-DIN	Protege Half DIN Rail 16 Input Expander
Power Supply	
DC Input Voltage	11-14VDC
DC Output Voltage (DC IN Pass-Through)	10.83-14.0VDC 0.7A (Typical) Electronic Shutdown at 1.1A
Operating Current	80mA (Normal Standby)
Total Combined Current*	3A (Max)
Low Voltage Cutout	8.7VDC
Low Voltage Restore	10.5VDC
Communication	
RS-485	Module Network
Inputs	
Inputs	16 High Security Monitored Inputs (10ms to 1hr Input Speed Programmable)
Trouble Inputs	16
Dimensions	
Dimensions (L x W x H)	78 x 90 x 60mm (3.1 x 3.5 x 2.4")
Net Weight	180g (6.3oz)
Gross Weight	240g (8.5oz)
Operating Conditions	
Operating Temperature	UL/cUL 0° to 49°C (32° to 120°F) : EU EN -10° to 55°C (14° to 131°F)
Storage Temperature	-10° to 85° C (14° to 185° F)
Humidity	0%-93% non-condensing, indoor use only (relative humidity)
Mean Time Between Failures (MTBF)	784,316 hours (calculated using RDF 2000 (UTE C 80-810) Standard)

\* The total combined current refers to the current that will be drawn from the external power supply to supply the expander and any devices connected to its outputs. The auxiliary outputs are directly connected via thermal resettable fuses to the N+ N- input terminals, and the maximum current is governed by the trip level of these fuses. It is important that the unit is installed in a dry cool location that is not affected by humidity. Do not locate the unit in air conditioning or a boiler room that can exceed the temperature or humidity specifications.

Integrated Control Technology continually strives to increase the performance of its products. As a result these specifications may change without notice. We recommend consulting our website ([www.ict.co](http://www.ict.co)) for the latest documentation and product information.

# New Zealand and Australia

---

## General Product Statement

The RCM compliance label indicates that the supplier of the device asserts that it complies with all applicable standards.



# European Standards

---

## CE Statement

Conforms where applicable to European Union (EU) Low Voltage Directive (LVD) 2014/35/EU, Electromagnetic Compatibility (EMC) Directive 2014/30/EU, Radio Equipment Directive (RED) 2014/53/EU and RoHS Recast (RoHS2) Directive: 2011/65/EU + Amendment Directive (EU) 2015/863.

This equipment complies with the rules, of the Official Journal of the European Union, for governing the Self Declaration of the CE Marking for the European Union as specified in the above directive(s).



### Information on Disposal for Users of Waste Electrical & Electronic Equipment

This symbol on the product(s) and / or accompanying documents means that used electrical and electronic products should not be mixed with general household waste. For proper treatment, recovery and recycling, please take this product(s) to designated collection points where it will be accepted free of charge.

Alternatively, in some countries you may be able to return your products to your local retailer upon purchase of an equivalent new product.

Disposing of this product correctly will help save valuable resources and prevent any potential negative effects on human health and the environment, which could otherwise arise from inappropriate waste handling.

Please contact your local authority for further details of your nearest designated collection point.

Penalties may be applicable for incorrect disposal of this waste, in accordance with your national legislation.

### For business users in the European Union

If you wish to discard electrical and electronic equipment, please contact your dealer or supplier for further information.

### Information on Disposal in other Countries outside the European Union

This symbol is only valid in the European Union. If you wish to discard this product please contact your local authorities or dealer and ask for the correct method of disposal.

## EN50131 Standards

This component meets the requirements and conditions for full compliance with EN50131 series of standards for equipment classification.

EN 50131-1:2006+A2:2017, EN 50131-3:2009, EN 50131-6:2008+A1:2014, EN 50131-10:2014, EN 50136-1:2012, EN 50136-2:2013, EN 60839-11-1:2013

### Security Grade 4

### Environmental Class II

Equipment Class: Fixed

Readers Environmental Class: IVA, IK07

SP1 (PSTN – voice protocol)

SP2 (PSTN – digital protocol)

SP6 (LAN – Ethernet) and DP1 (LAN – Ethernet + PSTN)

SP6 (LAN – Ethernet) and DP1 (LAN – Ethernet + USB-4G modem)

**Tests EMC (operational)** according to EN 55032:2015

**Radiated disturbance** EN 55032:2015

**Power frequency magnetic field immunity tests** (EN 61000-4-8)

## EN50131

In order to comply with EN 50131-1 the following points should be noted:

- Ensure for Grade 3 or 4 compliant systems, the minimum PIN length is set for 6 digits.
- To comply with EN 50131-1 Engineer access must first be authorized by a user, therefore Installer codes will only be accepted when the system is unset. If additional restriction is required then Engineer access may be time limited to the first 30 seconds after the system is unset.
- Reporting delay –Violation off the entry path during the entry delay countdown will trigger a warning alarm. The warning alarm should not cause a main alarm signal and is not reported at this time. It can be signaled locally, visually and or by internal siren type. If the area is not disarmed within 30 seconds, the entry delay has expired or another instant input is violated, the main alarm will be triggered and reported.
- To comply with EN 50131-1 neither Internals Only on Part Set Input Alarm nor Internals Only on Part Set Tamper Alarm should be selected.
- To comply with EN 50131-1 Single Button Setting should not be selected.
- To comply with EN 50131-1, only one battery can be connected and monitored per system. If more capacity is required, a single larger battery must be used.
- For Security Grade 4 installations, two forms of reporting are required. This can be satisfied using the onboard 2400bps modem included with the modem controller model, or through the incorporation of the PRT-4G-USB cellular modem module into the installation with the non-modem controller model.

### Anti Masking

To comply with EN 50131-1 Grade 3 or 4 for Anti Masking, detectors with a separate or independent mask signal should be used and the mask output should be connected to another input.

I.e. Use 2 inputs per detector. One input for alarm/tamper and one input for masking.

To comply with EN 50131-1:

- Do not fit more than 10 unpowered detectors per input,
- Do not fit more than one non-latching powered detector per input,
- Do not mix unpowered detectors and non-latching powered detectors on an input.

To comply with EN 50131-1 the Entry Timer should not be programmed to more than 45 seconds.

To comply with EN 50131-1 the Bell Cut-Off Time should be programmed between 02 and 15 minutes.

EN 50131-1 requires that detector activation LEDs shall only be enabled during Walk Test. This is most conveniently achieved by using detectors with a Remote LED Disable input.

To comply with EN 50131-1, EN 60839-11 Security Grade 4 and AS/NZS2201.1 class 4&5 Vibration Detection for PreTamper Alarm, protection is provided by a DSC SS-102 Shockgard Seismic vibration sensor mounted within the system enclosure. Alarm output is provided by a pair of non-latching, N.C. (normally closed) relay contacts, opening for a minimum of 1 second on detection of an alarm connected in series with the 24Hr tamper input (TP) on the PSU (or any other system input designated/programmed as a 24Hr Tamper Alarm).

This relay is normally energized to give fail-safe operation in the event of a power loss. Indication of detection is provided by a LED situated on the front cover. The vibration sensor is fully protected from tampering by a N.C. micro switch operated by removal of the cover.

Enclosure EN-DIN-24 has been tested and certified to EN50131.

By design, the enclosures for all Integrated Control Technology products, EN-DIN-11, EN-DIN-12 and EN-DIN-24-ATTACK, comply with the EN 50131 standards. Tamper protection against removal of the cover as well as removal from mounting is provided by tamper switch.

**Warning: Enclosures supplied by 3rd parties may not be EN50131-compliant, and should not be claimed as such.**

# UK Conformity Assessment Mark

---

## General Product Statement

The UKCA Compliance Label indicates that the supplier of the device asserts that it complies with all applicable standards.



# UL and cUL Installation Requirements

---

Only UL / cUL listed compatible products are intended to be connected to a UL / cUL listed control system.

## UL/cUL Enclosures

All UL/cUL installations must use an enclosure (cabinet) that is listed to the relevant UL or cUL standard.

ICT offers a range of UL- and cUL-listed enclosures that are suitable for installation of Protege DIN rail products and accessories such as batteries. For our enclosure listings, see one of the following locations:

- The UL/cUL-Listed Protege Enclosures reference document, available from the ICT website.
- [UL Product iQ](#)

## Central Station Signal Receiver Compatibility List

- IP Receiver via Ethernet Port: ArmorIP Internet Monitoring Receiver. Internet monitoring software and interconnected with a (DAXW/C) central station automation system software and compatible receiving equipment.
- CID Receiver via Onboard Modem: Any UL and cUL listed receiver that uses the Contact ID protocol.

Modem model only.

## cUL Compliance Requirements

### CAN/ULC-S304

- **Auto Arming**

Control units that support auto arming shall provide an audible signal throughout the protected area not less than 10 min prior to the auto arming taking place. The control unit shall allow authorized users to cancel the auto arming sequence and transmit such cancellation to the signal receiving center with the identification of the authorized user that canceled the action.

The following options must be enabled in the Protege system when using the Auto Arming feature. When the defer warning time is programmed to 10 minutes, the output group will be activated 10 minutes before the system performs the Auto Arming in the associated Area.

- The **Defer Output or Output Group** must be programmed. Refer to the section Areas | Outputs in the Operator Reference Manual for programming instructions.
- The **Defer Warning Time** must be programmed to not less than 10 minutes. Refer to the section Areas | Configuration in the Operator Reference Manual.
- The **Defer Automatic Arming** option must be enabled. Refer to the section Areas | Options (2) in the Operator Reference Manual.

- **Arming Signal**

A bell or visual indicator used as an arming acknowledgment signal must be listed to a cUL security, signaling or fire standard. If intended to be mounted outside, it must be rated for outdoor use.

- **Double EOL Input Configuration**

Only double EOL Input Configuration shall be used. Refer to the Inputs section of this manual and the section Inputs | Options in the Operator Reference Manual.

- **Multiplex System and Poll Time**

The Protege controller is compatible with the ArmorIP Internet Monitoring Receiver. Poll Time must be set to 40 seconds and the Grace Time must be set to 20 seconds.

In the Protege system, the reporting service must be configured to 40 seconds. The following options are required for the service selected as Report IP type:

- The **Log Polling Message** option must be enabled. Refer to the section Report IP | Options in the Operator Reference Manual.
- The **Poll Time** must be programmed to 40 seconds. Refer to the Report IP | General section in the Operator Reference Manual.

- **Central Station Signal Receiver**

The common equipment of each signal receiving center control unit shall be limited to 1000 alarm systems.

- **Number of attempts**

In the event of unsuccessful communication, a digital alarm communicator transmitter shall make a minimum of 5 and a maximum of 10 attempts. Where the maximum number of attempts to complete the sequence is reached, an indication of the failure shall be made at the premises.

In the Protege system, the reporting service selected as Contact ID must have the number of attempts programmed to 5 attempts. The **Dial Attempts** option must be programmed. Refer to the section Contact ID | Settings in the Operator Reference Manual.

If the PRT-4G-USB cellular modem is being used as the secondary reporting option in the installation, the Report IP service assigned to the cellular modem must be programmed as above.

- **Check-In Time**

DACT communication channel check-in time is not to exceed 24 hrs.

- **Trouble Input Service Test Report**

- The **Test Report Time** must be programmed. Refer to the section Controllers | Configuration in the Operator Reference Manual.
- The **Generate Input Restore on Test Input** option must be enabled. Refer to the section Controller | Options in the Operator Reference Manual.
- The **Test Report Time is Periodic** option must be enabled. Refer to the section Controller | Options in the Operator Reference Manual.

- **Primary Communication Channel**

The first attempt to send a status change signal shall utilize the primary communication channel.

An ethernet Report IP service must be used as the primary service. The backup service may use Contact ID over the phone line or Report IP over the cellular network if the PRT-4G-USB cellular modem is being used as the secondary communication channel.

The following options are required:

- The primary service (Report IP) must have the **Backup service** set to the secondary reporting service (Contact ID or Report IP over 4G modem). The **Service mode** must be set to 1 - Start with controller OS.
- The backup service must have **Service operates as backup** enabled. For ULC-S304 P3 applications, **Enable offline polling** must be enabled and configured so that the backup service is monitored even when it is not active.
- For Report IP services, the **Reporting protocol** must be set to Armor IP.
- Refer to the Services section in the Operator Reference Manual.

- **Status Change Signal**

An attempt to send a status change signal shall utilize both primary and secondary communication channels.

- **Local Annunciation if Signal Reporting Failure**

Failure of the primary communication channel or secondary communication channel shall result in a trouble signal being transmitted to the signal receiving center within 240 seconds of the detection of the fault. Failure of either communication channel shall be annunciated locally within 180 seconds of the fault.

The following options must be enabled in the Protege system:

- The **Ethernet Link Failure** trouble input must be programmed.
- The **Trouble Input Area** must be armed. Refer to the section Trouble Inputs | Areas and Input Types in the Operator Reference Manual.

- **Network and Domain Access**

Neither the subscriber control unit nor the signal receiving center receiver shall be susceptible to security breaches in general-purpose operating systems.

Network access policies should be set to restrict unauthorized network access and "spoofing" or "denial of service" attacks.

- **Ethernet Connections**

All ethernet network connections shall be installed within the same room as the equipment.

- **Encryption**

For active communications channel security, encryption shall be enabled at all times.

The ArmorIP-E (UDP or TCP) protocol must be used and the Encryption Type must be set to AES-256.

The following options must be enabled for the Report IP service in the Protege system.

- The **Reporting Protocol** must be set to ArmorIP (UDP) Encrypted or ArmorIP (TCP) Encrypted. The AES key must be set as specified by monitoring station.
- Refer to the section Report IP | General in the Operator Reference Manual.

- **Server Configuration**

Where a server is employed for control over network addressing, encryption or re-transmission, such shall be designed to remain in the "on state" at all times.

Communicators are not suitable for active communication channel security and medium or high risk applications unless such can be "online" at all times, have a minimum 128 bit encryption scheme, have encryption enabled, network and domain security implemented.

Network access policies shall be set to restrict unauthorized network access and "spoofing" or "denial of service" attacks.

- **Internet Service Provider (ISP)**

The Internet Service Provider (ISP) providing service shall meet the following requirements:

- redundant servers/systems
- back-up power
- routers with firewalls enabled and
- methods to identify and protect against "Denial of Service" attacks (i.e. via "spoofing")

- **Information Technology Equipment, Products or Components of Products**

Products or components of products, which perform communications functions only, shall comply with the requirements applicable to communications equipment as specified in CAN/CSA-C22.2 No. 62368-1, Audio/video, information and communication technology equipment - Part 1: Safety requirements. Where network interfaces, such as the following, are internal to the subscriber control unit or receiver, compliance to CAN/CSA-C22.2 No. 62368-1 is adequate. Such components include, but are not limited to:

- A) Hubs;
- B) Routers;
- C) Network interface devices;
- D) Third-party communications service providers;
- E) Digital subscriber line (DSL) modems; and
- F) Cable modems.

- **Backup Power Requirements**

Power for network equipment such as hubs, switchers, routers, servers, modems, etc., shall be backed up or powered by an uninterruptible power supply (UPS), stand-by battery or the control unit, capable of facilitating 24h standby, compliant with Clauses 16.1.2 and 16.4.1 of CAN/ULC-S304.

For communications equipment employed at the protected premises or signal receiving center and intended to facilitate packet switched communications, as defined in CAN/ULC-S304, 24h back-up power is required.

- **Compromise Attempt Events**

ArmorIP detects the reception of any invalid packet on the programmed port as a potential system **compromise attempt**. Each compromise attempt sends a notification to the receiver, and logs a Compromise Attempt event under the Live Panel Events.

The event is sent with the following details:

- **Account Code** as defined in the Serial Receiver settings
- **Event Code** 0x163
- **Group Code** as defined in the Serial Receiver settings
- **Point Code** as defined in the Serial Receiver settings

Refer to the section [Global Settings | Serial Receiver](#) in the *ArmorIP Version 3 Internet Monitoring Application User Manual*.

For UL and cUL installations the Central Station Receiving software must have the Contact ID details as specified, programmed for the **Compromise Attempt** event.

- **Power Supply Mains Power Connection**

If a flexible cord is used to connect to line voltage, strain relief must be provided for the cord inside the enclosure or at the knockout.

The power supply is not intended to be mounted on the exterior of vault, safe, or stockroom.

## CAN/ULC-S559

### Signal Reporting

The reporting services and other components shall be programmed so as to meet the requirements of CAN/ULC-S559 for either an active or passive communication system.

This includes the following provisions:

- All signals must be transmitted to the fire signal receiving center within 60 seconds.
- An active communication system shall use one or more IP reporting services. Any fault in the primary reporting service must be detected and annunciated at the fire signal receiving center within 180 seconds.
- IP reporting services may utilize either the controller's onboard ethernet or the PRT-4G-USB cellular modem. The **Reporting Protocol** must be set to *ArmorIP* with at least 128 bit encryption. Either UDP or TCP may be used.
- A passive communication system shall use two or more communication channels. The primary channel is a Contact ID service over the phone line, with a test signal sent at least every 6 hours. The phone dialer must make a minimum of 5 and a maximum of 10 attempts to dial the receiving center in the event of a communication failure.
- In passive systems, a DAYR7-listed cellular alarm communicator (e.g. DSC LE4010) must provide the backup channel and phone line integrity monitoring. The alarm communicator must be installed and configured in accordance with the manufacturer's instructions for CAN/ULC-S559 (commercial fire reporting) installations.

Further details and programming instructions are provided in *Application Note 362: CAN/ULC-S559 Fire Reporting in Protege Systems*.

### Central Station Signal Receiver

The signal receiving software must be ICT *ArmorIP* Version 3. It must meet the following requirements:

- The **Poll Time** must be set to 40 seconds and the **Poll Grace Time** must be set to 20 seconds.
- The maximum number of signal transmitting units connected to the *ArmorIP* Receiver shall not exceed 10000 simultaneous connections.
- The system shall be redundant. For up to 1000 accounts, two computers must be used. Each subsequent set of 1000 accounts requires another two computers.

For instructions and hardware requirements, see the *ArmorIP Version 3 Internet Monitoring Application User Manual*.

### Ethernet Connections

All ethernet network connections shall be installed within the same room as the equipment.

### External Wiring

All wiring extending outside of the enclosure must be protected by metal conduits.

## Power Supply Mains Power Connection

If a flexible cord is used to connect to line voltage, strain relief must be provided for the cord inside the enclosure or at the knockout.

The power supply is not intended to be mounted on the exterior of vault, safe, or stockroom.

## Backup Power

See your power supply installation manual for backup battery power requirements for the Protege system.

Telecom equipment (switches, modems, routers) requires 24hr of standby backup power.

## Arming Signal

A bell or visual indicator used as an arming acknowledgment signal must be listed to a cUL security, signaling or fire standard. If intended to be mounted outside, it must be rated for outdoor use.

## Keypad Wiring

The RS-485 connection to the keypad must be wired such that the shorts and other faults on the RS-485 line connection of the keypad will not cause the controller to malfunction.

## Fire Zone Inputs

Inputs 1, 2 and 3 on the controller or input expander must be connected to the Fire, Supervisory and Trouble outputs on the fire alarm control panel, as indicated in the diagrams below.

- EOL resistors must be installed at the fire alarm control panel outputs. Typical input circuits are:

Value 1	Value 2	Monitored Status
1k	1k	Open, Closed, Tamper, Short
6k8	2k2	Open, Closed, Tamper, Short
10k	10k	Open, Closed, Tamper, Short
2k2	2k2	Open, Closed, Tamper, Short
4k7	2k2	Open, Closed, Tamper, Short
4k7	4k7	Open, Closed, Tamper, Short

See the Inputs section of the controller or expander installation manual for connection diagrams.

- These inputs must have a fire area assigned, and the area must be armed. Areas used for fire reporting must not also be used for burglary.
- These inputs must be used exclusively for fire monitoring and cannot be programmed to activate the bell output.

Further details and programming instructions are provided in Application Note 362: CAN/ULC-S559 Fire Reporting in Protege Systems.

## Trouble Monitoring

The following trouble inputs must have the system area assigned with the Trouble Silent input type.

- Controller Service Report Test
- Controller ContactID Reporting Failure
- Controller ReportIP Reporting Failure
- Power Supply (Analog Expander) Mains Failure

The 24 hour portion of the system area must be armed at all times.

Provided that the Power Supply Mains Failure trouble input is monitored and reported to the receiving center, it is not necessary to display a visible LED indication outside the cabinet when there is a mains power failure.

Further details and programming instructions are provided in Application Note 362: CAN/ULC-S559 Fire Reporting in Protege Systems.

### Indicating Reporting Failures

Reporting failures must be indicated on the user interface for the system. There are two methods for achieving this:

- Sites with keypads can display the trouble message on the keypad.
- If the fire alarm control panel has a COM Status input, it may be connected to any available dry relay contact on the controller or output expander. When there is a reporting failure, the relay will turn on to activate the COM Status indicator on the fire alarm control panel.

Depending on how this relay is programmed, it may latch on when a reporting failure occurs. If so, a normally open monitoring reset button must be provided on controller input 4 to reset the relay output.

Further details and programming instructions are provided in Application Note 362: CAN/ULC-S559 Fire Reporting in Protege Systems.

## Active/Passive Communication System Diagrams

### CAN/ULC-S559 INPUT EXPANDER ACTIVE COMMUNICATION

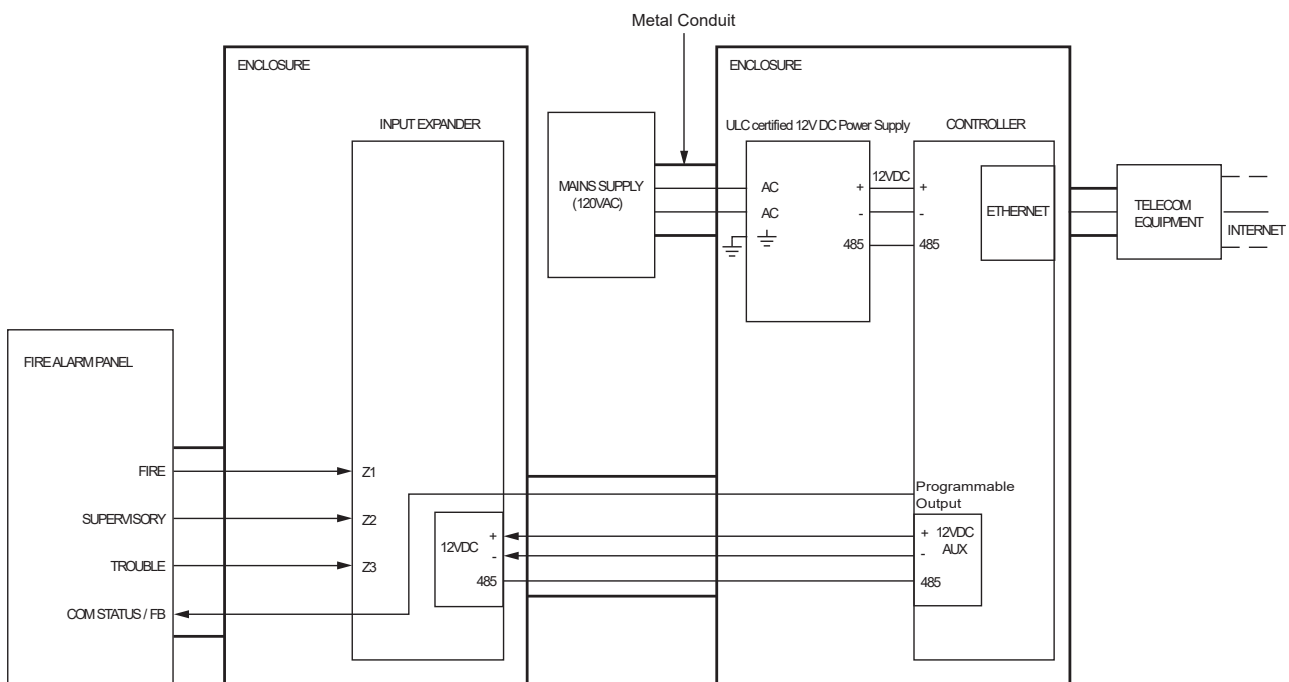

CAN/ULC-S559  
 INPUT EXPANDER  
 PASSIVE COMMUNICATION: MODEM DIALER

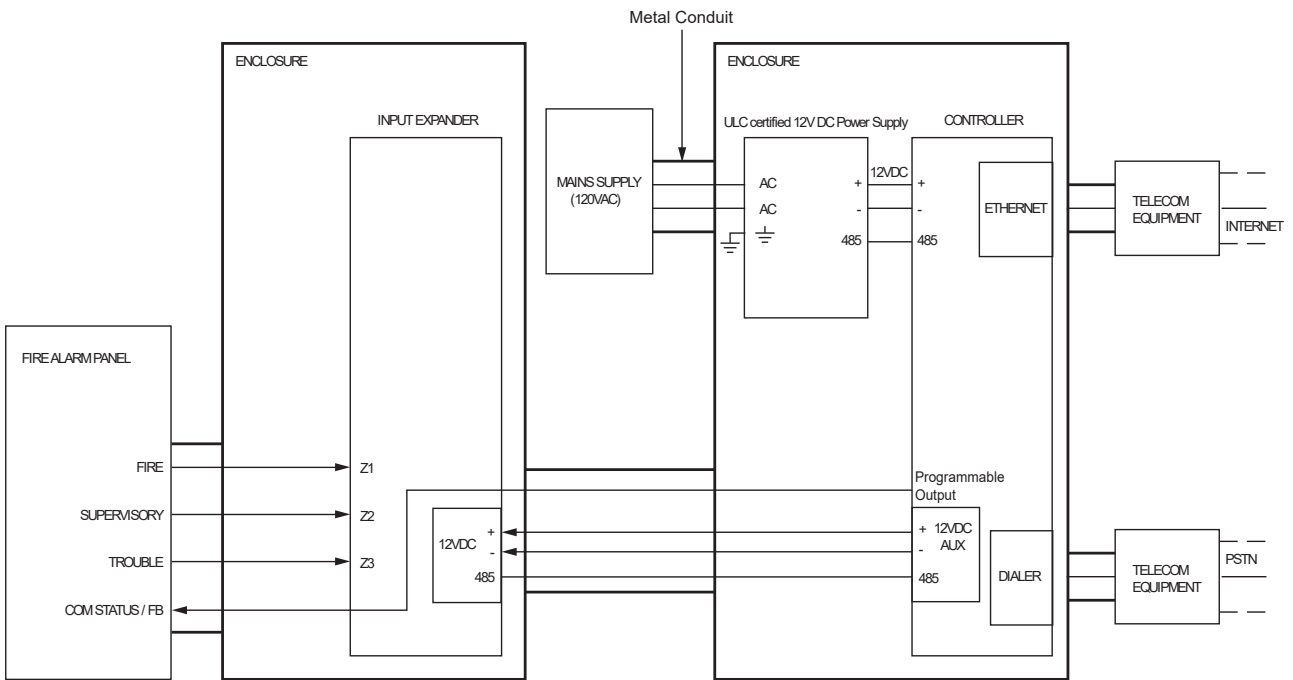

CAN/ULC-S559  
 INPUT EXPANDER  
 ACTIVE COMMUNICATION: CELLULAR MODEM

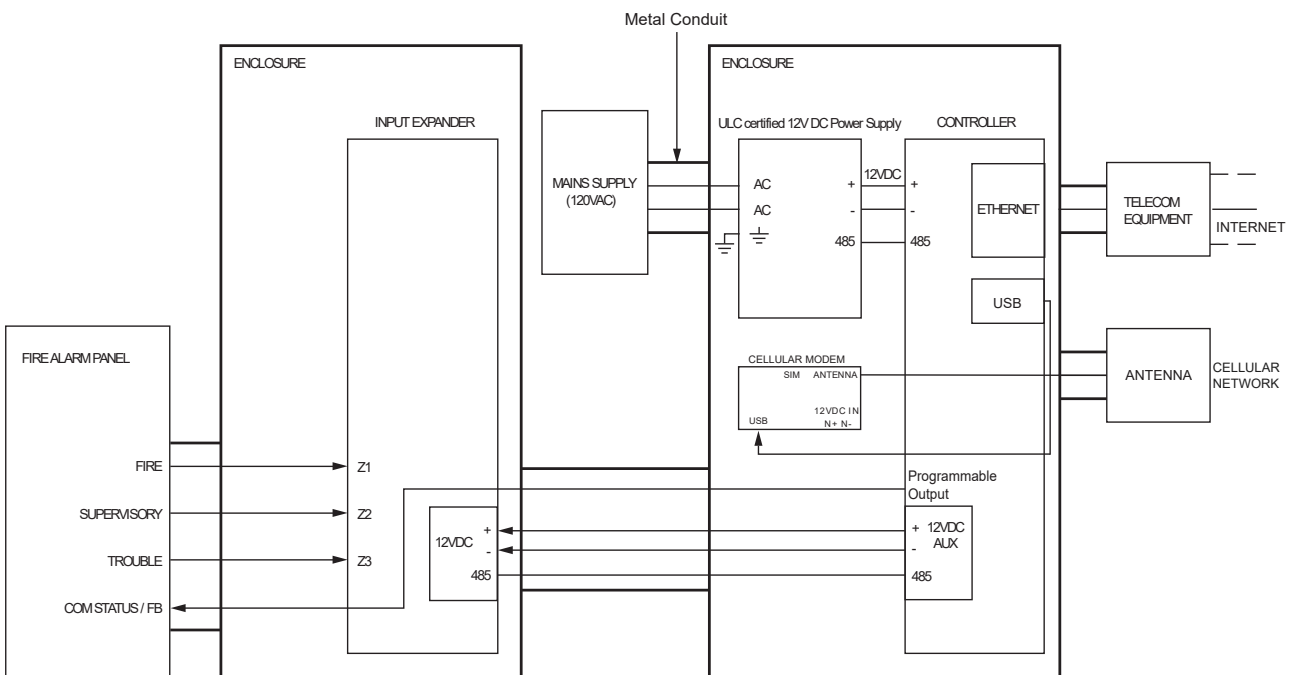

## UL Compliance Requirements

### UL1610

For Security Grade 4 installations, two forms of reporting are required. This can be satisfied using the onboard 2400bps modem included with the modem controller model, or through the incorporation of the PRT-4G-USB cellular modem module into the installation with the non-modem controller model.

- A local alarm sounding device, alarm housing, and control unit shall comply with the mercantile requirements in the Standard for Police Station Connected Burglar Alarm Units and Systems, UL365.
- A bell or visual indicator used as an arming acknowledgement signal must be listed to a UL security, signaling or fire standard. If intended to be mounted outside, it must be rated for outdoor use.
- Exit and entry delay must not exceed 60 seconds. To program the entry and exit delay time, refer to the section Areas | Configuration in the Operator Reference Manual.
- All ethernet network connections shall be installed within the same room as the equipment.
- Signals between the premises control unit and the receiving equipment, when not carried by wireless means, shall be protected by the following method:
  - Onboard modem telco connection must be dedicated to the Protege controller.

Modem model only.

- Ethernet connection to the Internet Service Provider (ISP) with a fixed IP Address must be dedicated to the Protege controller.
- To comply with the dual signal line transmission system requirement, both transmission lines (onboard modem and IP reporting) must be enabled. Signals shall be sent simultaneously to both the primary communications channel and the Backup Service.

The Report IP and Contact ID services must be programmed and enabled within the Protege system. The following options are required:

- The **Contact ID Reporting Service** must be enabled and the **Service Mode** must be configured to start with the operating system.
- Refer to the section Contact ID in the Operator Reference Manual.
- The **Report IP Service** must be enabled as the primary communication channel, the **Service Mode** must be configured to start with the operating system, and the **Reporting Protocol** must be set to ArmorIP.
- Refer to the section Report IP in the Operator Reference Manual.
- When more than one means of signal transmission is used, loss of communication with the receiving system shall be annunciated at the receiver within 200 seconds. If a fault is detected on any of the signal transmission means, at least one of the signal transmission channels shall send a signal to the central-station to report the fault within 200 seconds.

The Report IP and Contact ID services must be programmed and enabled within the Protege system.

The Protege controller is compatible with the ArmorIP Internet Monitoring Receiver. Poll Time must be set to 40 seconds and the Grace Time must be set to 20 seconds.

In the Protege system, the reporting service must be configured to 40 seconds. The following options are required for the service selected as Report IP type:

- The **Poll Time** must be programmed to 40 seconds. Refer to the Report IP | General section in the Operator Reference Manual
- The **Contact ID Reporting Service** must be enabled and the **Service Mode** must be configured to start with the operating system.
- Refer to the section Contact ID in the Operator Reference Manual
- The **Report IP Service** must be enabled as the primary communication channel, the **Service Mode** must be configured to start with the operating system, and the **Reporting Protocol** must be set to ArmorIP.
- Refer to the section Report IP in the Operator Reference Manual.
- The **Trouble Input Area** must be armed in 24h mode. Refer to the section Trouble Inputs | Areas and Input Types in the Operator Reference Manual.

In the event of unsuccessful communication, a digital alarm communicator transmitter shall make a minimum of 5 and a maximum of 10 attempts. Where the maximum number of attempts to complete the sequence is reached, an indication of the failure shall be made at the premises.

In the Protege system, the reporting service selected as Contact ID must have the number of attempts programmed to 5 attempts. The following options are required:

- The **Dial Attempts** option must be programmed. Refer to the section Contact ID | Settings in the Operator Reference Manual.

- DACT communication channel check-in time is not to exceed 24 hrs.
- Trouble Zone Service Test Report
  - The **Test Report Time** must be programmed. Refer to the section Controllers | Configuration in the Operator Reference Manual.
  - The **Generate Input Restore on Test Input** option must be enabled. Refer to the section Controller | Options in the Operator Reference Manual.
  - The **Test Report Time is Periodic** option must be enabled. Refer to the section Controller | Options in the Operator Reference Manual.
  - ArmorIP detects the reception of any invalid packet on the programmed port as a potential system **compromise attempt**. Each compromise attempt sends a notification to the receiver, and logs a Compromise Attempt event under the Live Panel Events.  
The event is sent with the following details:
    - **Account Code** as defined in the Serial Receiver settings
    - **Event Code** 0x163
    - **Group Code** as defined in the Serial Receiver settings
    - **Point Code** as defined in the Serial Receiver settings
 Refer to the section Global Settings | Serial Receiver in the ArmorIP Version 3 Internet Monitoring Application User Manual.  
For UL and cUL installations the Central Station Receiving software must have the Contact ID details as specified, programmed for the **Compromise Attempt** event.
- If a flexible cord is used to connect to line voltage, strain relief must be provided for the cord inside the enclosure or at the knockout.
- The power supply is not intended to be mounted on the exterior of vault, safe, or stockroom.

# FCC Compliance Statements

---

## FCC Rules and Regulations CFR 47, Part 15, Subpart B

This equipment complies with the limits for a Class A digital device, pursuant to Part 15 of the FCC rules.

Operation is subject to the following two conditions:

- This device may not cause harmful interference.
- This device must accept any interference received, including interference that may cause undesired operation.

NOTE: THE GRANTEE IS NOT RESPONSIBLE FOR ANY CHANGES OR MODIFICATIONS NOT EXPRESSLY APPROVED BY THE PARTY RESPONSIBLE FOR COMPLIANCE. SUCH MODIFICATIONS COULD VOID THE USER'S AUTHORITY TO OPERATE THE EQUIPMENT.

# Industry Canada Statement

---

## ICES-003

This class A digital apparatus complies with Canadian ICES-003.

Cet appareil numérique de la classe A est conforme à la norme NMB-003 du Canada.

CAN ICES-3 (A)/NMB-3(A)

# Disclaimer and Warranty

---

**Disclaimer:** Whilst every effort has been made to ensure accuracy in the representation of this product, neither Integrated Control Technology Ltd nor its employees shall be liable under any circumstances to any party in respect of decisions or actions they may make as a result of using this information. In accordance with the ICT policy of enhanced development, design and specifications are subject to change without notice.

For warranty information, see our [Standard Product Warranty](#).

Designers & manufacturers of integrated electronic access control, security and automation products.  
Designed & manufactured by Integrated Control Technology Ltd.  
Copyright © Integrated Control Technology Limited 2003-2026. All rights reserved.

**Disclaimer:** Whilst every effort has been made to ensure accuracy in the representation of this product, neither Integrated Control Technology Ltd nor its employees shall be liable under any circumstances to any party in respect of decisions or actions they may make as a result of using this information. In accordance with the ICT policy of enhanced development, design and specifications are subject to change without notice.