



**PRT-PSU-DIN-5A**

# **Protege DIN Rail 5A Intelligent Power Supply**

Installation Manual



The specifications and descriptions of products and services contained in this document were correct at the time of printing. Integrated Control Technology Limited reserves the right to change specifications or withdraw products without notice. No part of this document may be reproduced, photocopied, or transmitted in any form or by any means (electronic or mechanical), for any purpose, without the express written permission of Integrated Control Technology Limited. Designed and manufactured by Integrated Control Technology Limited, Protege® and the Protege® Logo are registered trademarks of Integrated Control Technology Limited. All other brand or product names are trademarks or registered trademarks of their respective holders.

Copyright © Integrated Control Technology Limited 2003-2026. All rights reserved.

Last Published: 23-Jan-26 3:29 PM

# Contents

<b>Introduction</b>	<b>6</b>
Software and Firmware Prerequisites	6
<b>Installation Requirements</b>	<b>7</b>
Safety Notice	7
Avis de Sécurité	7
<b>Grounding Requirements</b>	<b>9</b>
Safety Grounding	9
Earth Ground Connection	9
<b>Mounting</b>	<b>11</b>
Removal	11
<b>Wiring</b>	<b>12</b>
Wiring Requirements	12
Quick-Connect Terminals	13
Power-Limited Supply (NEC ANSI/NFPA 70)	14
<b>Mains Power</b>	<b>15</b>
<b>Backup Battery</b>	<b>16</b>
UL/cUL Backup Battery Requirements	16
Fully Loaded Backup	16
Minimum Standby Backup	17
EN 50131-1 Backup Battery Requirements	17
Connecting the Battery	17
Backup Battery Monitoring	19
Backup Battery Thresholds	19
<b>Encrypted Module Network</b>	<b>20</b>
Module Wiring	21
End-of-Line (EOL) Resistors	21
<b>Output Load Connection</b>	<b>23</b>
Inductive Loads	23
Output Current Influence on Output Load Operation	24
Core Temperature on Output Load Operation	24
<b>Outputs</b>	<b>25</b>
Online Mode	25
Programmable Outputs	25
Offline Mode	25

AC Fail Status Output .....	26
Battery Fail Status Output .....	26
<b>Tamper Detection</b> .....	<b>28</b>
Cabinet Tamper Switch .....	28
Vibration Sensor .....	29
Connection .....	29
Modes of Operation .....	30
Installation Procedure .....	30
<b>Trouble Inputs</b> .....	<b>33</b>
<b>Intelligent Monitoring</b> .....	<b>34</b>
Monitoring Setup .....	34
<b>Address Configuration</b> .....	<b>35</b>
<b>LED Indicators</b> .....	<b>36</b>
Status Indicator .....	36
Fault Indicator .....	36
Power Indicator .....	36
V1 Output/V2 Output Indicators .....	36
Battery Indicator .....	37
Temp Indicator .....	37
Output Current Indicator .....	37
<b>Error Code Indication</b> .....	<b>38</b>
Error Code Display .....	38
<b>Maintenance</b> .....	<b>39</b>
<b>Troubleshooting</b> .....	<b>40</b>
Firmware Upgrade Failure .....	40
<b>Mechanical Diagram</b> .....	<b>42</b>
<b>Mechanical Layout</b> .....	<b>43</b>
<b>Technical Specifications</b> .....	<b>44</b>
<b>New Zealand and Australia</b> .....	<b>46</b>
ASIAL Class 5 .....	46
<b>European Standards</b> .....	<b>47</b>
<b>UL and cUL Installation Requirements</b> .....	<b>49</b>
UL/cUL Enclosures .....	49
UL/cUL Firmware Version .....	49
cUL Compliance Requirements .....	49
CAN/ULC-60839-11-1 .....	49

CAN/ULC-S304 .....	50
CAN/ULC-S559 .....	52
UL Compliance Requirements .....	56
UL294 .....	56
UL2610 .....	57
<b>FCC Compliance Statements</b> .....	<b>58</b>
<b>Industry Canada Statement</b> .....	<b>59</b>
<b>IEC 62368-1:2020</b> .....	<b>60</b>
<b>Disclaimer and Warranty</b> .....	<b>61</b>

# Introduction

---

The Protege DIN Rail 5A Intelligent Power Supply provides 12VDC power suited to powering security, access control or automation devices along with Protege network-powered modules, and allows for simple and powerful monitoring of supply currents and voltages.

Flexible module network architecture allows large numbers of modules to be connected to the RS-485 module network. Up to 250 modules can be connected to the Protege system in any combination to the network, over a distance of up to 900M (3000ft). Further span can be achieved with the use of a network repeater module.

The current features of the power supply include:

- Secure encrypted RS-485 module communications
- Industry standard DIN rail mounting
- Online and remote upgradeable firmware
- Live monitoring of voltage, current, core temperature and battery status in Protege GX
- Two outputs for standalone status monitoring or programmed functions
- Dedicated cabinet tamper input

## Software and Firmware Prerequisites

Connecting the power supply to the Protege RS-485 module network enables you to monitor the power supply's status and control its onboard programmable outputs from Protege GX or Protege WX.

The following software and firmware versions are required to bring the power supply online with Protege GX or Protege WX:

Component	Version
Protege GX	4.3.352.10 (Long Term Support Release), or 4.3.390 or higher
Protege GX Controller	2.08.1535 or higher
Protege WX Controller	4.00.2438 or higher

If the power supply is connected to an earlier Protege system or third-party system, you can still monitor the power supply's status using the onboard outputs (see page 25).

# Installation Requirements

---

This equipment is to be installed in accordance with:

- The product installation instructions
- UL 294 - Access Control System Units
- UL 681 - Installation and Classification of Burglar and Holdup Systems
- UL 827 - Central-Station Alarm Services
- CAN/ULC-S301, Central and Monitoring Station Burglar Alarm Systems
- CAN/ULC-S302, Installation and Classification of Burglar Alarm Systems for Financial and Commercial Premises, Safes and Vaults
- CAN/ULC-S561, Installation and Services for Fire Signal Receiving Centres and Systems
- CAN/ULC-60839-11-1, Alarm and Electronic Security Systems – Part 11-1: Electronic Access Control Systems – System and Components Requirements
- The National Electrical Code, ANSI/NFPA 70
- The Canadian Electrical Code, Part I, CSA C22.1
- AS/NZS 2201.1 Intruder Alarm Systems
- The Local Authority Having Jurisdiction (AHJ)

## Safety Notice

This power supply includes internal protection against short circuits, overloads and overheating failures. Do not open the plastic case or attempt to bypass these features. For loads connected directly to the power supply outputs (except for devices on the RS-485 module network), appropriate in-line fuses should be installed as close to the power supply output as practical. For UL/cUL installations, you must use UL/cUL-listed fuses.

### DANGER

#### **ELECTRIC SHOCK, FIRE, EXPLOSION OR ARC FLASH**

Do not open the power supply's case or bypass electrical safety features.

**Failure to follow these instructions will result in death or serious injury.**

Opening the power supply's case or bypassing electrical safety features will **void any warranties or guarantees**.

The power supply cannot protect against shorts, overloads and overheating of the backup battery. Always connect and handle the battery correctly in accordance with the [Connecting the Battery](#) section and the manufacturer's recommendations.

## Avis de Sécurité

Ce bloc d'alimentation comprend une protection interne contre les courts-circuits, les surcharges et les défaillances dues à la surchauffe. Ne pas ouvrir le boîtier en plastique ni tenter de contourner ces dispositifs de protection. Pour les charges branchées directement aux sorties du bloc d'alimentation (à l'exception des dispositifs sur le réseau de modules RS-485), des fusibles en ligne appropriés devraient être installés aussi près que possible de la sortie du bloc d'alimentation. Pour les installations UL/cUL, vous devez utiliser des fusibles homologués UL/cUL.

## **DANGER**

### **CHOC ÉLECTRIQUE, INCENDIE, EXPLOSION OU ARC ÉLECTRIQUE**

Ne pas ouvrir le boîtier du bloc d'alimentation ni contourner les dispositifs de sécurité électrique.

**Le non-respect de ces instructions entraînera la mort ou des blessures graves.**

L'ouverture du boîtier du bloc d'alimentation ou le contournement des dispositifs de sécurité électrique **annulera toute garantie.**

Le bloc d'alimentation ne peut pas protéger contre les courts-circuits, les surcharges et la surchauffe de la batterie de secours. Toujours brancher et manipuler la batterie correctement conformément à la section [Connecting the Battery](#) et aux recommandations du fabricant.

# Grounding Requirements

---

An effectively grounded product is one that is intentionally connected to earth ground through a ground connection or connections of sufficiently low impedance and having sufficient current-carrying capacity to prevent elevated voltages that may result in undue hazard to connected equipment or to persons.

Grounding of the Protege system is done for three basic reasons:

1. Safety
2. Component protection
3. Noise reduction

## Safety Grounding

The object of safety grounding is to ensure that all metalwork is at the same ground (or earth) potential. Impedance between the Protege system and the building scheme ground must conform to the requirements of national and local industrial safety regulations or electrical codes. These will vary based on country, type of distribution system and other factors. The integrity of all ground connections should be checked periodically.

General safety dictates that all metal parts are connected to earth with separate copper wire or wires of the appropriate gauge.

<b>⚠ CAUTION / ATTENTION</b>	
<p><b>ELECTRIC SHOCK</b></p> <p>All cabinet internal covers and lids/doors must be connected to the cabinet's main ground point for electrical safety and static discharge protection.</p> <p><b>Failure to follow these instructions can result in injury.</b></p>	<p><b>CHOC ÉLECTRIQUE</b></p> <p>Tous les couvercles internes et portes/couvercles de l'armoire doivent être reliés au point de mise à la terre principal de l'armoire pour assurer la sécurité électrique et la protection contre les décharges électrostatiques.</p> <p><b>Le non-respect de ces instructions peut entraîner des blessures.</b></p>

## Earth Ground Connection

The DIN rail enclosure and the DIN rail modules must be grounded to a suitable single-point earth ground connection in the installation. A minimum 14AWG solid copper wire (or thicker, in accordance with local authorities) shall be used from the Protege system's earth connection points.

The DIN rail enclosure includes an earth ground single-point link connection via the metallic enclosure. This single-point link is the Protege system's earth ground. All modules that have earth ground connections and that are installed in the same enclosure shall be connected to this single point. A single-point earth ground connection avoids the creation of ground loops in the system and provides a single reference point to earth ground.

**DIN Rail Ground Connections (one or more cabinets installed in the same room)**

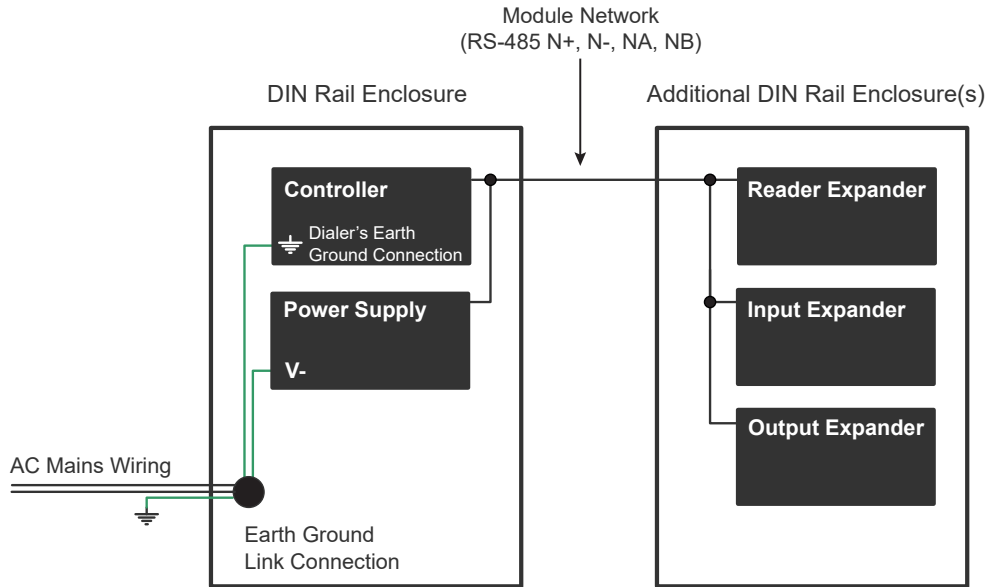

**DIN Rail Ground Connections (multiple cabinets in different rooms, sectors, or buildings)**

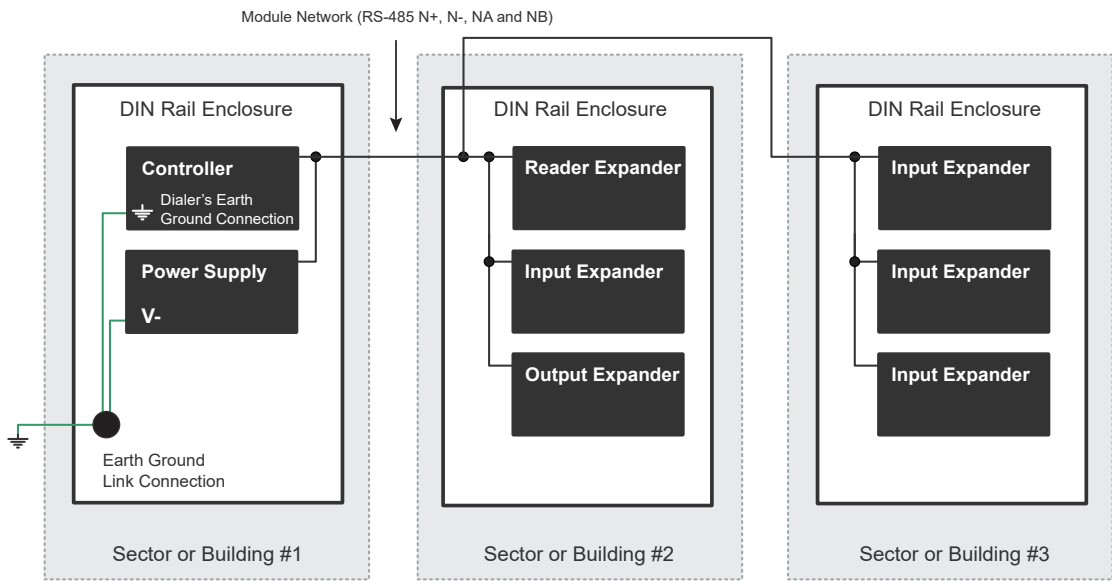

The Dialer's Earth Ground Connection applies to modem model controllers only.

Note that the DIN rail enclosure earth terminal is connected to the power supply V- terminal.

**NOTICE**

**DEGRADATION OF COMMUNICATION OR EQUIPMENT DAMAGE**

There must be only one single earth grounding point per system.

**Failure to follow these instructions can result in degradation of communication and equipment damage.**

# Mounting

---

Protege DIN rail modules are designed to mount on standard DIN rail, either in dedicated DIN cabinets or on generic DIN rail mounting strip.

## Location

Protege DIN rail modules must be installed indoors, within the protected area. Modules must be protected by a secure cabinet with tamper detection.

We recommend installing the cabinet in a location that provides easy access for wiring. Suitable locations include electrical rooms, communication equipment rooms and accessible areas of the ceiling. Ensure that there is adequate clearance around each device and that air flow to the vents is not restricted.

Protege DIN rail modules must not be installed outdoors. Ensure that the room does not exceed or fall below the operating temperature or humidity ranges listed in the Technical Specifications for each module. Do not mount cabinets on the exterior of a vault, safe or stockroom.



For UL/cUL installations, you must use a UL- or cUL-listed enclosure. See the full certification list in the UL/cUL-Listed Protege Enclosures document, available from the ICT website.

All cabinet installations of this type must be located **inside the Protected Area. Not** to be mounted on the exterior of a vault, safe or stockroom.

## Mounting a DIN Rail Module

To mount a module onto DIN rail:

1. Position the module with the labeling in the correct orientation.
2. Hook the mounting tabs (opposite the tab clip) under the edge of the DIN rail.
3. Push the DIN rail module against the mount until the tab clips over the rail.

## Removal

To remove the DIN rail module from the DIN rail mount:

1. Insert a flat-blade screwdriver into the slot in the module tab clip.
2. Lever the tab outwards and rotate the unit off the DIN rail mount.

# Wiring

**Notice:** Incorrect wiring may result in damage to the unit.

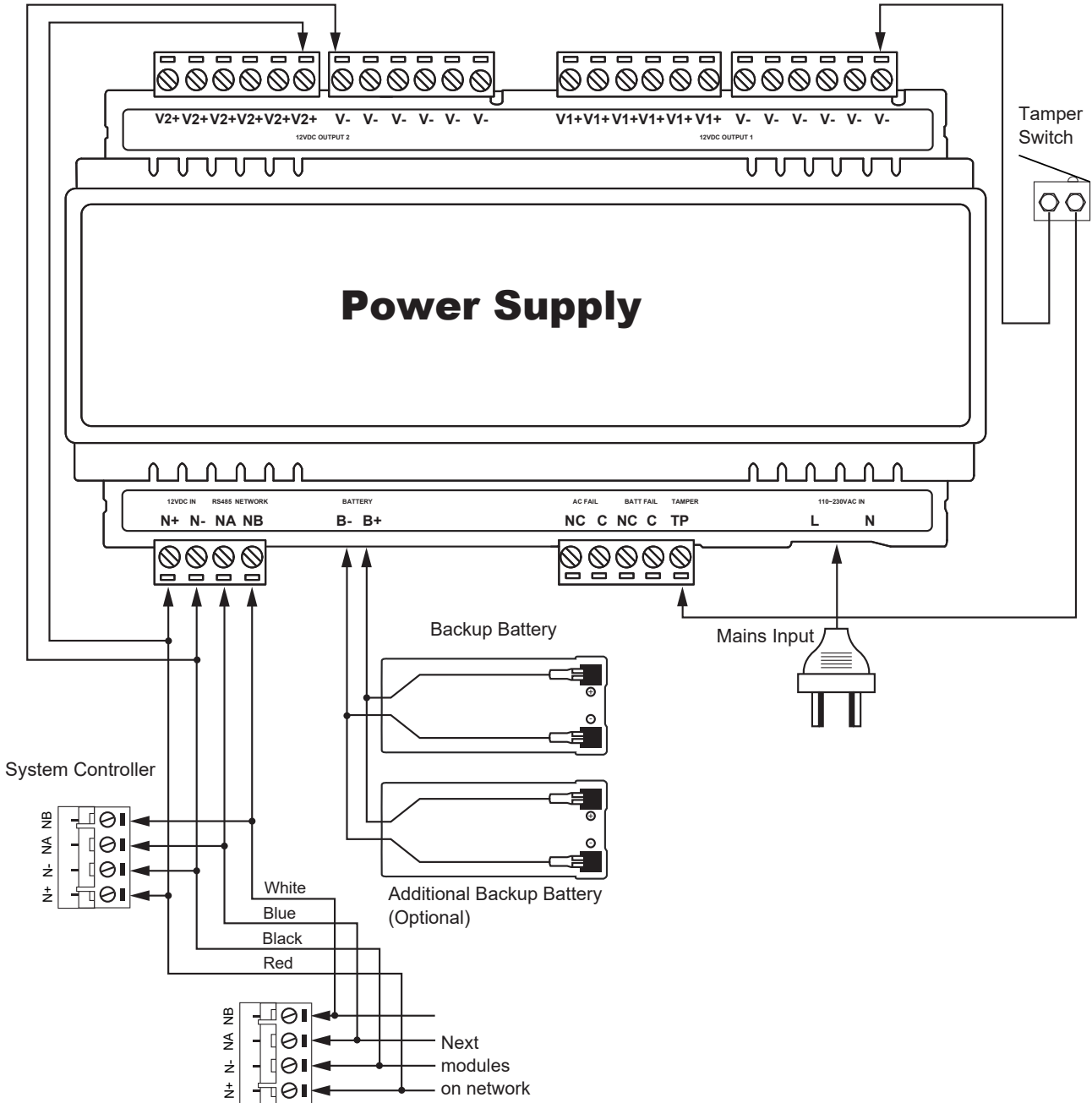

For CAN/ULC-S559 fire reporting installations, refer to the figures in the CAN/ULC-S559 section (see page 55).

## Wiring Requirements



For UL/cUL installations, the following wiring specifications must be observed.

**Aux Wiring:** Minimum 22AWG, maximum 16AWG (depends on length and current consumption).

For wire/cable size, a maximum of 5% voltage drop at the terminals of the powered device must be observed.

**Module Network Wiring:**

- Minimum 24AWG (0.51mm) shielded twisted pair with characteristic impedance of 120Ω. Maximum length 900m (3000ft).
- CAT5e / CAT6 also supported for data transmission when using ground in the same cable. Maximum length 100m (330 ft).

Do not use extra wires in the cable to power devices.

<b>⚠ DANGER</b>	
<p><b>FIRE</b></p> <p>Always use cables with sufficient gauge for the required current. Cables with insufficient gauge can overheat and create a risk of fire.</p> <p><b>Failure to follow these instructions will result in death or serious injury.</b></p>	<p><b>INCENDIE</b></p> <p>Toujours utiliser des câbles de calibre suffisant pour le courant requis. Les câbles de calibre insuffisant peuvent surchauffer et présenter un risque d'incendie.</p> <p><b>Le non-respect de ces instructions entraînera la mort ou des blessures graves.</b></p>

**Power-limited Circuits (NEC)**

Power-limited circuits must be separated by at least 7mm (¼") from all electric light, power, Class 1 conductors, non-power-limited fire-protective signaling conductors, or medium-power network-powered broadband communications-circuit conductors. Refer to the wiring diagrams for the correct wiring arrangements.

**Strain Relief**

You must provide strain relief for the mains power cord, battery cables and all cables connected to quick-connect terminals. ICT DIN rail cabinets include finger trunking channels and cable tie points to provide strain relief.

**Mains Connection**

Do not connect the power supply to a receptacle controlled by a switch.

## Quick-Connect Terminals

Quick-connect terminals on this module make it easy to connect wires to the terminal blocks. Plastic connectors are provided alongside the module.

To use the quick-connect terminals:

1. Remove the plastic connector from the terminal block you are planning to wire. You can use a small flat-blade screwdriver to gently lever the connector out of the module.  
If the connectors are already loose, select a plastic connector with the same number of terminals as the block you are planning to wire.
2. Loosen the screw above each slot that you will connect a wire to.
3. Identify the wires that you will connect to these terminals. Strip back the insulation to approximately 3mm (1/8") from the end of each wire.
4. Using a crimping tool, crimp the end of each wire.
5. Insert each wire into the matching slot. Ensure that the wire is sitting above the metal plate.
6. Tighten each screw, raising the metal plate until the wire is secure. Do not overtighten.
7. Push the connector firmly into the terminal block.

## Power-Limited Supply (NEC ANSI/NFPA 70)

This power supply is considered a power-limited supply in the United States National Electrical Code (NEC ANSI/NFPA 70), as it provides less than 8A of current.

# Mains Power

The power supply should be supplied by a dedicated electrical power source rated for a minimum 5 amp load and have a dedicated circuit breaker.

Connect the power supply module to the mains output via an appropriate IEC-C7 90 degree cable. The cable must be at least 1.85m (6ft) and the wire gauge must be appropriate to provide AC power.

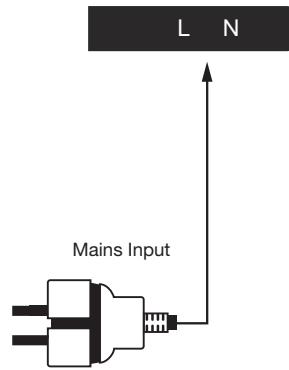

The earth wire shall be routed to the V- terminal on the power supply.

## ⚠ CAUTION / ATTENTION

### ELECTRIC SHOCK

- This installation should be made by qualified service personnel and should conform to all local codes.
- Power the unit only after all wiring is completed.
- Do not terminate wiring to the power supply while power is supplied or the battery is connected.

**Failure to follow these instructions can result in injury.**

### CHOC ÉLECTRIQUE

- Cette installation doit être effectuée par du personnel qualifié et doit être conforme à tous les codes locaux en vigueur.
- Mettre l'appareil sous tension uniquement après avoir terminé tout le câblage.
- Ne pas raccorder le câblage au bloc d'alimentation lorsque l'alimentation est sous tension ou que la batterie est branchée.

**Le non-respect de ces instructions peut entraîner des blessures.**

## NOTICE

### EQUIPMENT DAMAGE

Ensure correct wiring of AC inputs and use only the appropriate AC cable for this unit.

**Failure to follow these instructions can result in equipment damage.**

Failure to follow the instructions above will **void all warranties or guarantees.**



Plug connection not evaluated by UL/cUL.

# Backup Battery

---

A battery backup must be connected to the module network to provide a monitored supply. The battery plays an important role in power conditioning and provides a continuous source of power in the event of a power outage.

- **Battery Type:** Sealed lead acid (SLA) rechargeable battery.
- **Cables and Connectors:** ICT provides a battery connection cable with the power supply. **You must use the cable provided by ICT.**

The supplied cable has spade (F2) terminals, the most common type of terminal for SLA batteries. If you have a larger battery with nut and bolt (NB) terminals, you must use a pair of NB to F2 terminal adapters to connect the supplied cable to the battery. You can order these adapters from a battery accessory supplier.

- **Battery Capacity:** Minimum 7Ah at 12V. More capacity may be required to meet applicable regulations.
- **Number of Batteries:** If more capacity is required, multiple batteries of the same age and specifications can be connected in parallel (if permitted by applicable regulations).
- **Battery Life:** Typically, SLA batteries need to be replaced every 3-5 years. However, this varies based on the battery model, usage and environmental conditions. Review the technical datasheet provided by the battery manufacturer to determine the expected life for your batteries, paying attention to the following factors:
  - Capacity derating in different temperature conditions
  - Discharge characteristics under different loads
  - Life characteristics in stand-by use
  - Standing/Inactivity periods

To prevent premature battery failure, install the battery in the environmental conditions recommended by the manufacturer.

## UL/cUL Backup Battery Requirements

UL/cUL installations must use an appropriate UL/cUL-listed battery.

The battery capacity must be sufficient to supply the system for a specific period of time. The specifications below show the minimum required battery capacity to supply the system when fully loaded or at minimum standby power (depending on the applicable standards).

The required capacity may be provided by two batteries in parallel or one larger battery. For example, a capacity of 14Ah may be supplied by 2 × 7Ah batteries or 1 × 14Ah battery. If your system is larger than the minimum standby system or you want a longer backup time, you may connect batteries with more capacity. Calculate the standby current draw or fully loaded current for your system and the battery rating needed to run that system for the required time.

Backup batteries must be installed in a UL/cUL-listed cabinet with at least 7mm (¼ inch) of clearance between the battery and the inside surface of the cabinet. If the selected batteries do not fit in the same cabinet as the power supply, they may be installed in a secondary UL/cUL-listed cabinet. The cables connecting the two cabinets must be installed in a metal conduit.



For UL2610 Mercantile applications, the battery must be installed in a UL2610-listed enclosure.

## Fully Loaded Backup

These standards require the product to operate at full load for a certain period of time while on backup supply.

- The **Fully Loaded Output Current** is the full load that has been validated by UL/cUL for this application.
- The **Minimum Battery Rating** is the battery rating validated by UL/cUL for this application. More capacity may be connected as required.

Application	Fully Loaded Output Current	Minimum Battery Rating
UL 294 4hr backup (fully loaded system)	5000mA*	2 × 12VDC 12Ah = 24Ah
CAN/ULC 60839-11-1 4hr backup (fully loaded system)	5000mA*	2 × 12VDC 12Ah = 24Ah

\* Includes the current draw from the power supply board.

## Minimum Standby Backup

These standards require the product to operate at minimum standby power while on backup supply. The battery ratings in the following table have been calculated based on the standby system evaluated by UL/cUL.

- The **Maximum Validated Current** is the maximum current that has been validated by UL/cUL for this application.
- The **Minimum Standby Current** is the standby current draw of the minimum system validated by UL/cUL for this application. This is the load connected to the output terminals.
- The **Minimum Battery Rating** is the battery rating validated by UL/cUL for this application. This battery rating is capable of supplying the minimum standby current for the length of time specified in the standard. More capacity may be connected as required.

Application	Maximum Validated Current	Minimum Standby Current	Minimum Battery Rating
CAN/ULC-S304 24hr backup (standby)	5000mA*	180mA	2 × 12VDC 12Ah = 24Ah
CAN/ULC-S559 24hr backup (standby)	180mA	180mA	2 × 12VDC 7Ah = 14Ah
UL2610 - Mercantile 4hr backup (standby)	5000mA*	240mA	2 × 12VDC 12Ah = 24Ah

\* Includes the current draw from the power supply board.

## EN 50131-1 Backup Battery Requirements

To comply with EN 50131-1, only one battery can be connected and monitored per system. If more capacity is required, a single larger battery must be used.

EN 50131-1 compliance has not been evaluated by UL/cUL.

## Connecting the Battery

To connect the battery to the power supply:

1. If the battery has nut and bolt connectors, you must first attach the NB to F2 terminal adapters. Line up the hole of the adapter with the terminal, then secure the adapter with the nut and bolt.

2. Connect the **red** and **black** battery termination wires to the B+ and B- plugs on the power supply.
3. Connect the spade terminals to the battery or adapters, as shown below.

Connection of the battery in reverse will not damage the power supply, but will cause the battery circuit to disconnect until the correct connection is made.

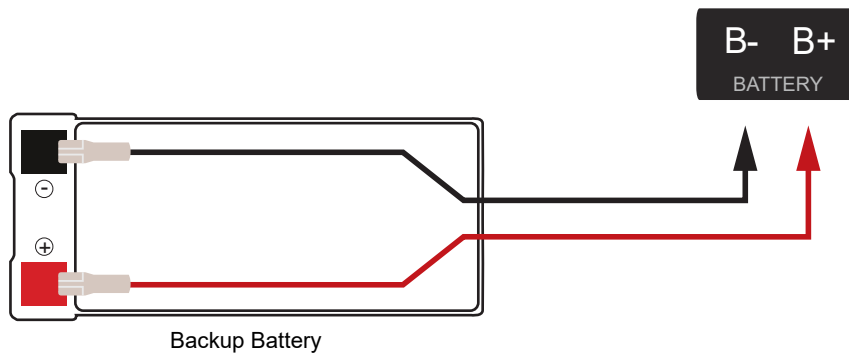

If required and permitted by regulations, two batteries may be connected in parallel to provide more capacity. We recommend that you use two identical batteries of the same age to prevent continuous discharge from the newer battery to the older battery.

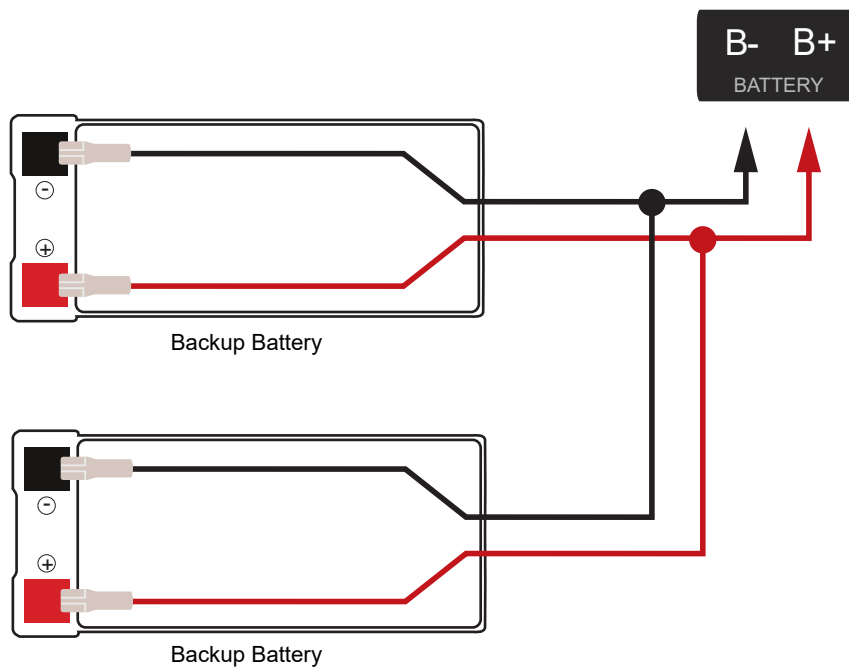

## ⚠ DANGER

### ELECTRIC SHOCK, FIRE OR EXPLOSION

- Only attach standard lead-acid batteries.
- Do not connect the battery wires or B+ and B- plugs of the module to any other ancillary device (siren, lock, mag clamp, etc.).
- Always use the cables and connectors provided by ICT.
- Use appropriate terminal adapters where the battery terminals do not match the terminals of the provided cables.
- Do not short-circuit the battery.
- Ensure all connections are performed correctly.

**Failure to follow these instructions will result in death or serious injury.**

### CHOC ÉLECTRIQUE, INCENDIE, EXPLOSION OU ARC ÉLECTRIQUE

- Brancher uniquement des batteries au plomb-acide standard.
- Ne pas brancher les fils de la batterie ou les fiches B+ et B- du module à tout autre dispositif auxiliaire (sirène, serrure, ventouse magnétique, etc.).
- Toujours utiliser les câbles et connecteurs fournis par ICT.
- Utiliser les adaptateurs de bornes appropriés lorsque les bornes de la batterie ne correspondent pas aux bornes des câbles fournis.
- Ne pas court-circuiter la batterie.
- S'assurer que tous les branchements sont effectués correctement.

**Le non-respect de ces instructions entraînera la mort ou des blessures graves.**

An incorrect connection may cause erroneous faults or serious damage to the module and will **void all warranties or guarantees**.

## Backup Battery Monitoring

The power supply performs a battery presence test every 60 seconds. If the backup battery has been disconnected, it will activate the 'Low Battery/Battery Failure' trouble input (online mode) or battery fail status output (offline mode).

## Backup Battery Thresholds

The table below illustrates the operation of the power supply during a mains power failure, based on the battery voltage.

Battery Voltage	Operation
Voltage $\geq 11.0V$	Normal operation Operation is restored after a battery failure
$11.0V > \text{Voltage} > 9.4V$	Normal operation with low battery warning: <ul style="list-style-type: none"><li>• Battery LED indicator flashing red</li><li>• Low Battery trouble input activated</li><li>• Battery Fail status output activated</li></ul>
Voltage $\leq 9.4V$	Disconnects from battery

All voltage values are measured across the B+ / B- terminals on the power supply, not at the battery.

Upon reconnection of mains power, the power supply automatically begins controlled charging at 600mA (typical), up to 630mA (maximum).

# Encrypted Module Network

The power supply is designed to supply power to the encrypted RS-485 module network. Network power is supplied by the N+ and N- terminals and communications by the NA and NB terminals.

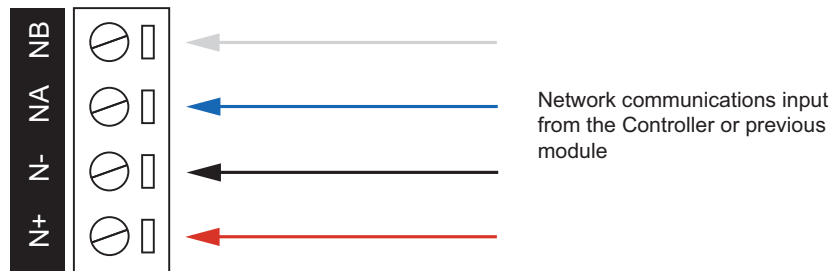

The diagram below shows how a single power supply can be connected to supply the module network. Power is provided by connecting the V+ and V- output terminals of the power supply to the N+ and N- terminals of the module network.

A single power supply is suitable for smaller systems, provided that the combined current required by all modules, card readers, bells and auxiliary devices is less than or equal to the total DC output current of the power supply.

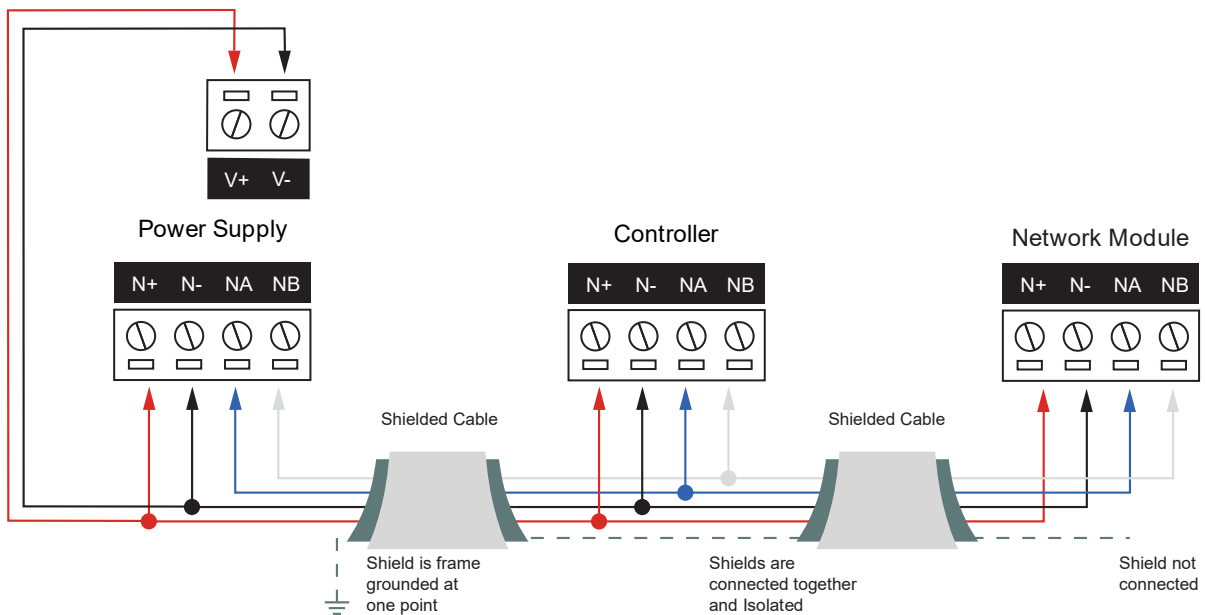

If the current requirements exceed what a single power supply can provide, a separate power supply must be used as shown below. Ensure that you **disconnect the N+ connection** between the two power supplies. Connections from more than one 12V supply may cause damage to the power supplies and other modules on the network.

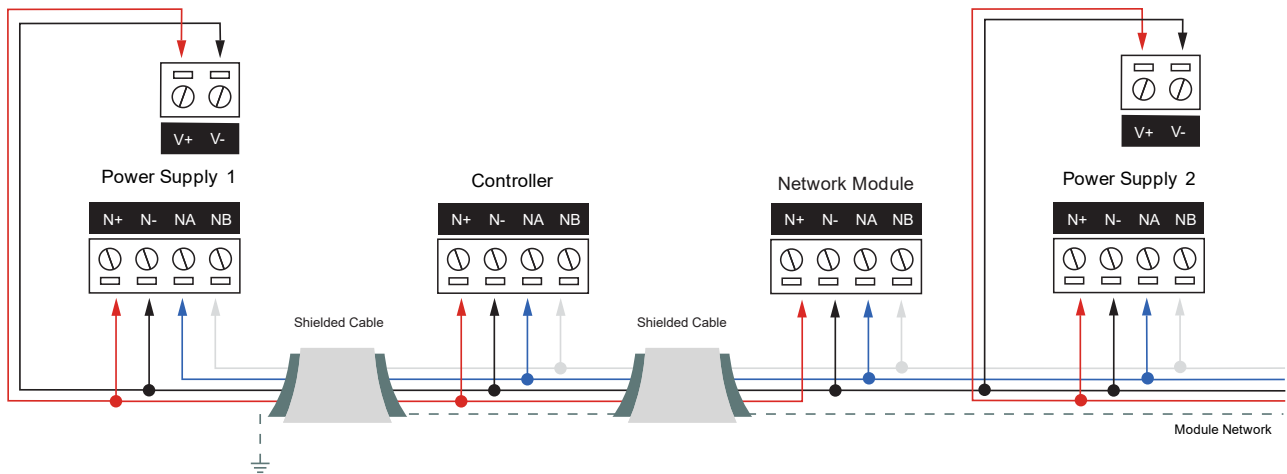

## NOTICE

### EQUIPMENT DAMAGE

The 12V N+ and N- input must be supplied from only **one** point.

**Failure to follow these instructions can result in equipment damage.**

## Module Wiring

The recommended module network wiring specifications are:

- Minimum 24AWG (0.51mm) shielded twisted pair with characteristic impedance of 120Ω
- Maximum total length of cable is 900m (3000ft)
- CAT5e / CAT6 are also supported for data transmission when using ground in the same cable (to a maximum length of 100m (328ft))

## NOTICE

### EQUIPMENT DAMAGE

Do not use unused wires in the cable to supply power to other devices.

**Failure to follow these instructions can result in equipment damage.**

## End-of-Line (EOL) Resistors

End-of-line resistors prevent signal reflections at the ends of the RS-485 network bus, improving signal strength and reducing data corruption.

You must insert a **120Ω resistor** between the NA and NB terminals of the **first** and **last** modules on the RS-485 network. These are the modules physically located at the ends of the RS-485 network cabling.

First Module on RS-485 Network

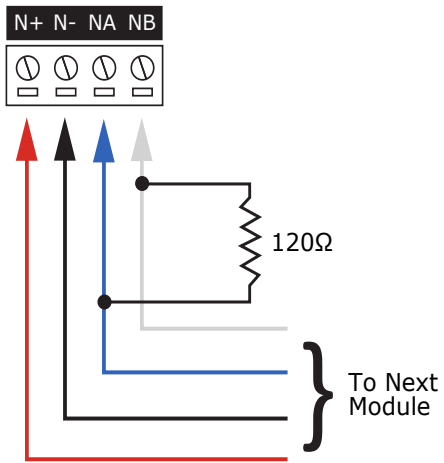

Last Module on RS-485 Network

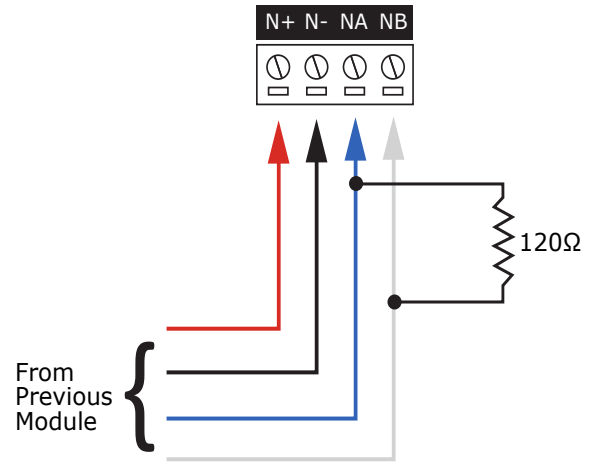

# Output Load Connection

The power supply provides two sets of 12VDC output terminals, V1+ and V2+. The two sets of terminals can provide a total combined current of 5.0A at 12VDC. You can draw the entire 5A from one set of terminals, or split it across both sets.



For UL/cUL applications, the maximum current draw is 5.0A (including the current draw of the power supply board).

When the power supply first boots up, it will take up to 5 seconds to start supplying power to the output terminals. During this time, the power or battery indicator will be on, but the V1 and V2 output indicators will remain off.

For loads connected directly to the power supply outputs (except for devices on the RS-485 module network), appropriate in-line fuses should be installed as close to the power supply output as practical. For UL/cUL installations, you must use UL/cUL-listed fuses.

## Inductive Loads

When any inductive load, including electric locking devices, is powered (directly or indirectly) by the power supply, a reverse EMF protection diode must be placed across the positive (V1+ or V2+) and negative (V-) terminals at the device.

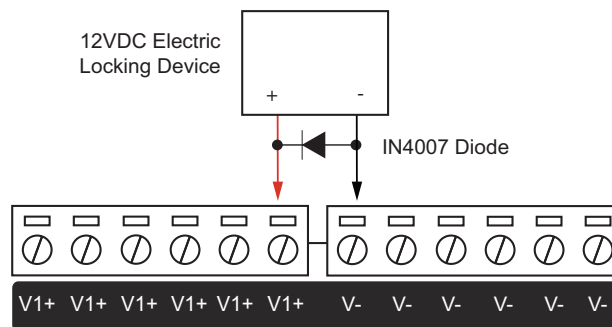

Note: The 1N4007 diode shown **must** be installed across the + and - terminals of any inductive load, such as electric locks, magnetic or motorized devices.

## Output Current Influence on Output Load Operation

The table below helps illustrate how the total output current drawn from the power supply module influences the operation of V1 and V2 outputs.

Output Load Operation Status	Output Load Current		
	0 - 5.2A	5.2 - 6.0A	6.0A - Short Circuit
Outputs Enabled (Mains Power)	✓	✓	
Outputs Supplied by Battery	✓	✓	
Output Over-Current Failure Trouble Input Activated		✓	✓
Over-Current Output Shutdown Activated			✓

## Core Temperature on Output Load Operation

The table below helps illustrate how the core temperature of the power supply module influences the operation of the V1 and V2 outputs.

Output Load Operation Status	Core Temperature		
	<70°C	70-80°C	>80°C
Outputs Enabled (Mains Power)	✓	✓	
Outputs Supplied by Battery	✓	✓	✓
Output Over-Current Failure Trouble Input Activated		✓	✓
Over-Current Output Shutdown Activated			✓

# Outputs

The power supply has two 50mA outputs that can operate as either programmable outputs or as predefined status outputs, depending on the network status of the module on the Protege system.

## Online Mode

Upon successfully completing the initial registration with any Protege system controller, the outputs of the power supply operate in **online mode**. While in online mode, the two outputs function as **programmable outputs** and can be used to activate bell sirens, lighting circuits, door locks, relay accessory products and other automation points.

## Programmable Outputs

The 2 programmable outputs each have a 50mA solid-state relay.

The connection example below shows the control of an external LED indicator.

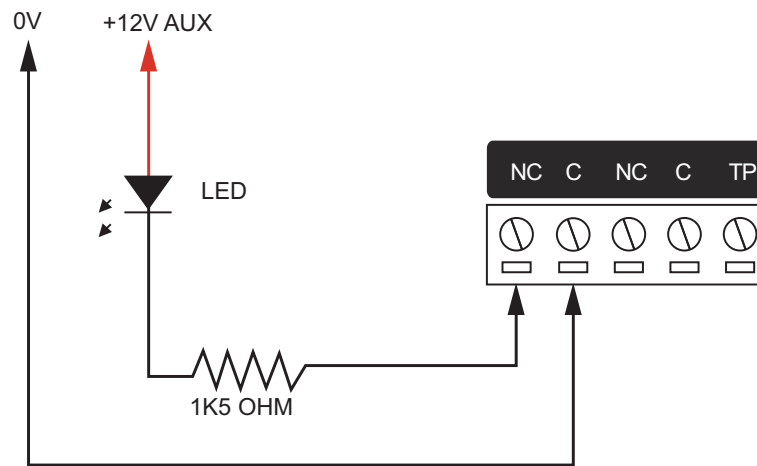

## NOTICE

### EQUIPMENT DAMAGE

- Use these outputs for low power applications only (50mA, 12V maximum).
- Switching inductive loads can produce high back EMF voltages or large voltage spikes that can cause the module to behave unexpectedly. Do not connect inductive loads directly to the module's relay contacts. Instead, install a suitable isolation circuit between the relay contacts of the module and the inductive load.

**Failure to follow these instructions can result in equipment damage.**

Incorrect use of the outputs can cause permanent damage to the power supply and will **void all warranties or guarantees**.

## Offline Mode

If the power supply has not been connected to a Protege system controller, it operates in **offline mode**. While in offline mode, the two outputs function as **status outputs**. In addition to the comprehensive front panel diagnostic indicators, these status outputs offer additional information that can aid the installer in diagnosing faults and conditions.

## AC Fail Status Output

The AC fail status output has a solid-state relay. The output relay contacts disconnect (normally open) when AC power is removed and the unit remains running on backup battery power. Upon restoring AC power, the output relay will revert to its default state (normally closed).

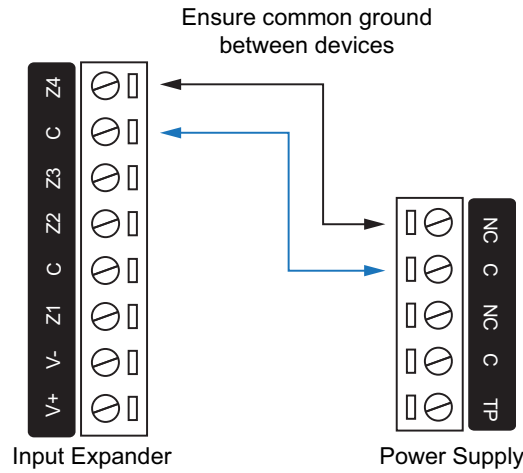

This output is suitable for connection to an input on a Protege module with spare inputs available so that the power supply AC status can be externally monitored. The connection example above shows monitoring of the AC status set up in conjunction with a Protege input expander.

## Battery Fail Status Output

The battery fail status output has a solid-state relay. The output relay contacts disconnect (normally open) when either the backup battery has been disconnected or the power supply is running on backup battery power without AC power and the backup battery voltage drops below the low battery threshold.

Upon reconnecting a backup battery with a voltage greater than the restore threshold, the output relay will revert back to its default state (normally closed).

For more information, see [Backup Battery Thresholds](#) (page 19).

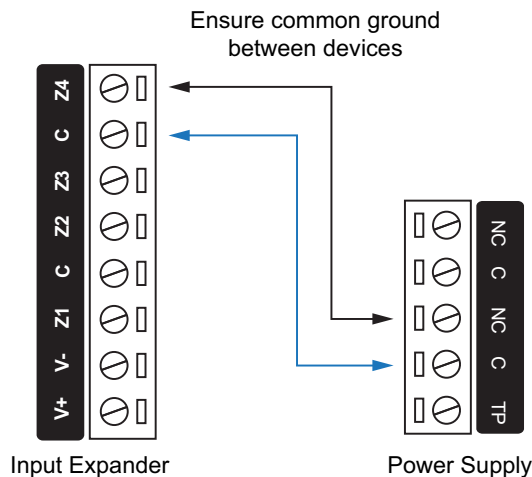

This output is suitable for connection to an input on the Protege system for early detection of complete power failure. The connection example above shows monitoring of the battery status set up in conjunction with an input expander.

## ***NOTICE***

### **EQUIPMENT DAMAGE**

Use these outputs for low power applications only (50mA, 12V maximum).

**Failure to follow these instructions can result in equipment damage.**

# Tamper Detection

The power supply includes a dedicated tamper input (TP) to provide protection for the cabinet. When the power supply detects someone attempting to open the cabinet, it opens the 'Module Tamper' trouble input.

## Cabinet Tamper Switch

The enclosure tamper input notifies the monitoring station or remote computer that the enclosure has been opened. If the tamper switch is already mounted in your ICT enclosure, simply cut the cable tie once the enclosure is in place to allow the switch to actuate. Otherwise, mount the tamper switch to the enclosure with the bracket provided.

When the tamper input switch terminals are connected in series with the dedicated tamper input (TP) and V- terminal of the power supply, it will open the trouble input AExxx:01 on the power supply. Alternatively, connect the tamper switch to any other system input designated and programmed as a 24HR tamper alarm input.

**Tamper Input Connection:**

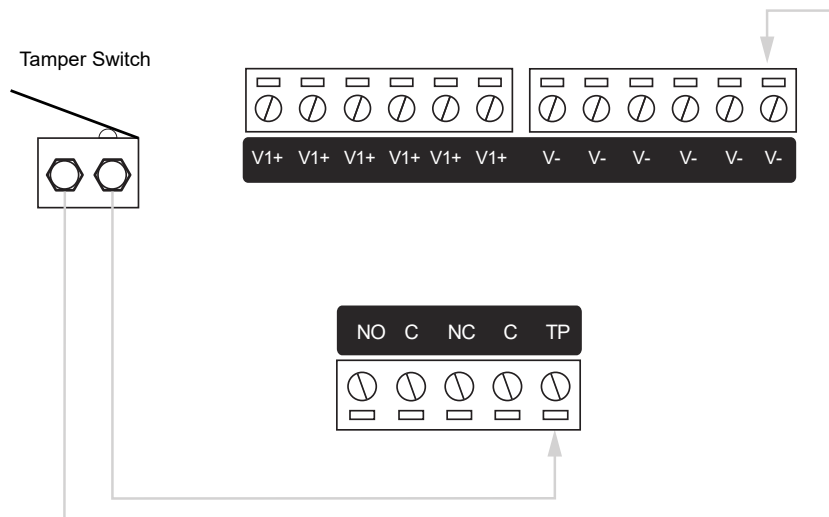

# Vibration Sensor

A DSC SS-102 Shockgard Seismic vibration sensor can be used to provide pre-tamper detection for the cabinet. This is required for AS/NZS 2201.1 Class 4 and 5, EN 50131-1 and EN 60839-11 Security Grade 4 installations.

The vibration sensor is mounted within the system enclosure, in series with the standard tamper switch.

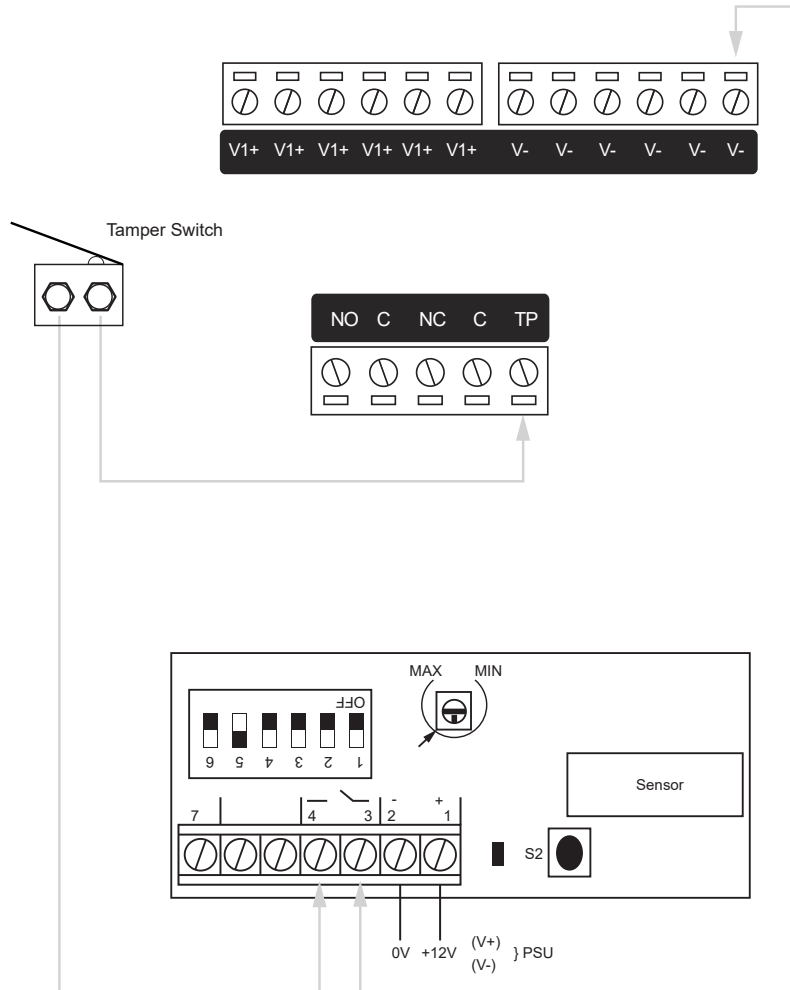

## Connection

- Terminals **1(V+)** and **2(V-)**. 12V power connection, reverse polarity protected.
- Terminals **3 and 4**. N.C. alarm output contacts, with a built-in 10Ω resistor in series.

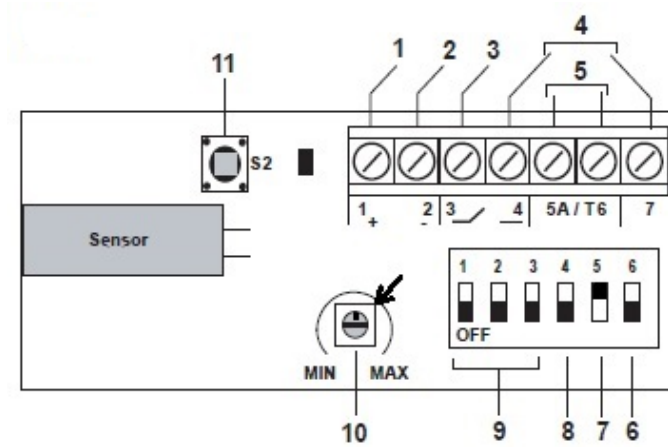

1. 12V (Screw terminal 1).
2. 0V (Screw terminal 2).
3. Alarm circuit. N/C contact. (Screw terminals 3&4).
4. Latch terminal (12V SET + SW +). Not used.
5. Anti-tamper. Terminals not used.
6. Not used. Off.
7. Sensitivity selection level (Low/High). Switch 5 set to on. High selected.
8. Latch reset switch. Not used. Off.
9. Pulse count selection switches. Not used. Off.
10. Sensitivity adjustment potentiometer.  
Set pointer marker to point at the corner opposite the MIN marker.
11. Case anti-tamper switch. Not used.

## Modes of Operation

When using the sensor in momentary mode it will be necessary to connect using a 4 core cable.

- The N.C. alarm contacts are non-latching.
- Upon alarm activation, the alarm contacts will open circuit momentarily for a minimum time of 1 second before automatically resetting.
- The LED will illuminate when the alarm contacts are open circuit in response to an input signal.
- LED indication: During the sensitivity test procedure indication of the **green** LED denotes alarm and relay operation. Indication of the **red** LED denotes vibration detected (pulse) but insufficient to create alarm conditions.
- Dual stage linear sensitivity: The detector permits the installer a greater threshold of sensitivity adjustment by adjustment of the potentiometer through either a low level or high level adjustment.
- When DIP Switch 5 is in the ON position the sensitivity potentiometer allows adjustment in the high sensitivity area and when in the OFF position allows adjustment in the low sensitivity area.

## Installation Procedure

1. Select the intended position for installation, ideally positioned horizontally in the vertical center of the enclosure, 50mm to the right of the large opening.

Ensure the surface is clean and clear of any irregularities.

2. Remove the sensor cover by unscrewing the single captive screw until the cover can easily be removed from the base.
3. Carefully lift the printed circuit board from the base.
4. Position the base in the mounting position and mark the desired fixing holes (3.1mm drill).
5. If rear cable entry is required, cables should be threaded through the rear of the base.
6. Fix the base in position using M3 pan head machine screws to the captive nuts provided in the enclosure, or with nuts and washers if located in an alternative position.

Take care not to let the screw protrude further than the nut height on the rear of the enclosure.

7. Carefully push the printed circuit board onto the base.
8. Make the electrical connections to the Shockgard SS-102, wired in series with the cabinet tamper switch.
9. If side cable entry is being used, remove the appropriate knockout from the cover and insert a grommet.
10. Setting up and adjustment:
  - With the unit in momentary operation (See Modes of Operation: Dual stage linear sensitivity above), use a terminal screwdriver to turn the sensitivity control fully clockwise to maximum (Position 6).
  - Using a suitable implement, bang or tap the protected area, observing the LED response.
  - Reduce the sensitivity by a small amount (turn sensitivity control anti-clockwise) and bang or tap the protected area.
  - Repeat this process until the unit only just responds to the desired impact.
11. Replace the sensor cover, tighten the fixing screw and check its response to the desired impact.

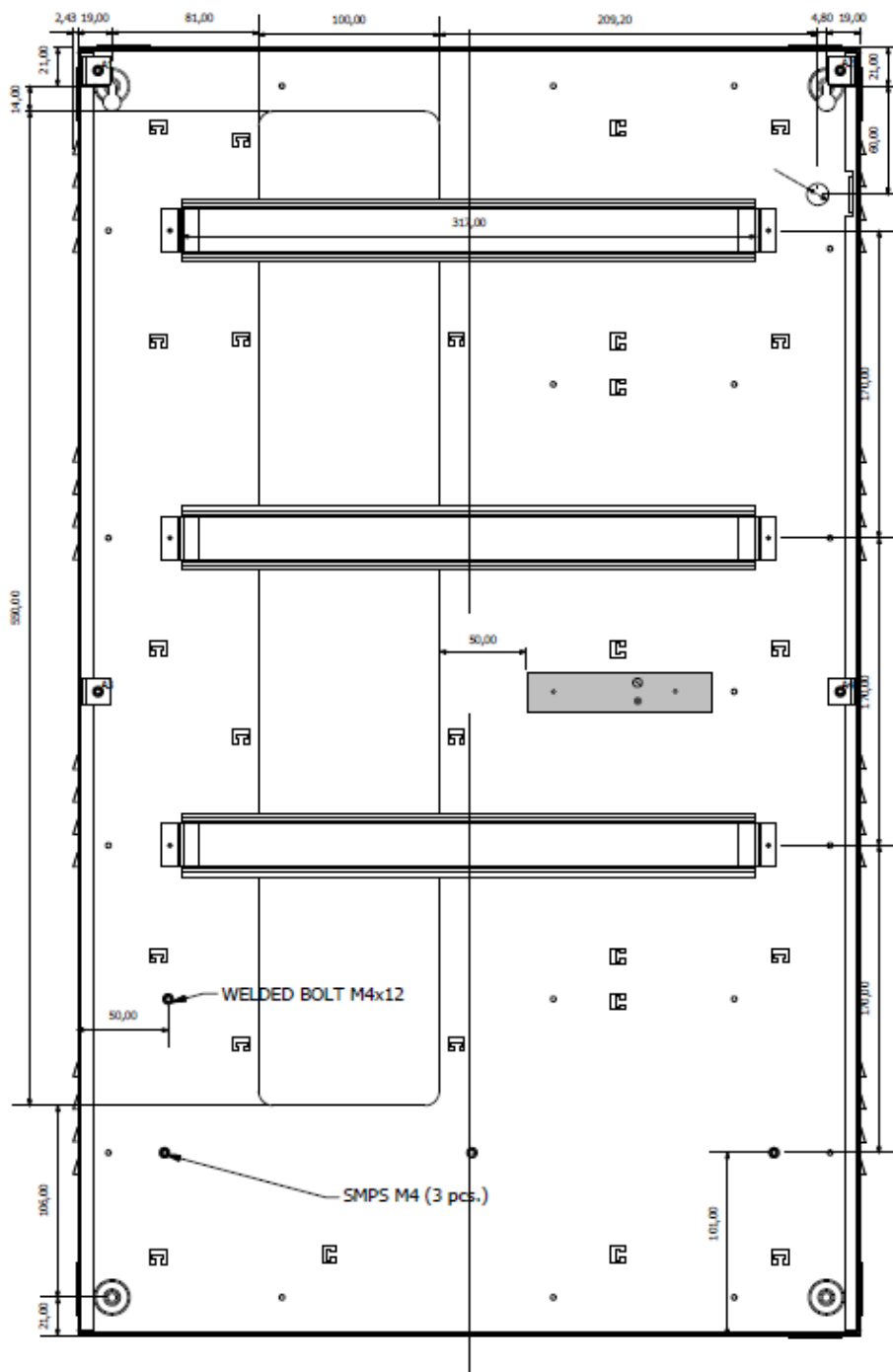

# Trouble Inputs

---

Each power supply can monitor up to 8 trouble inputs.

Trouble inputs are used to monitor the module status and in most cases are not physically connected to an external input.

The following table details the trouble inputs that are configured in the system and the trouble groups that they are associated with.

Input Number	Description	Default Trouble Group	Default Trouble Group Option
AExxx:01	Module Tamper	System	System Tamper
AExxx:02	Mains Failure	General	Power Fault
AExxx:03	Low Battery/Battery Failure	General	Power Fault
AExxx:04	Output Voltage Low	General	Power Fault
AExxx:05	Output Over-Current Failure	General	Power Fault
AExxx:06	Core Temperature Over-Temp Failure	General	Power Fault
AExxx:07	Reserved	None	None
AExxx:08	Module Offline	System	Module Offline

Replace 'xxx' with the address of the module that you are programming.

The power supply is an analog expander module on the Protege module network. This means that all programming, trouble input and output information is stored in and reported by the analog expander records when programming via the Protege software.

# Intelligent Monitoring

---

The power supply is able to relay information about critical system voltages, currents and temperature to the Protege GX controller by registering as an analog expander module on the Protege network. The controller can then store these values in variables that can be viewed live from the Protege GX interface.

This feature is not available in Protege WX or Protege X.

## Monitoring Setup

The power supply will register with the Protege GX controller as an analog expander module, AExxx.

The analog expander has four channels for monitoring input data. The channels monitor the following data:

- Channel 1: Voltage at V2+ output
- Channel 2: Voltage at V1+ output
- Channel 3: Power supply module core voltage
- Channel 4: Total current output

To monitor a channel, assign a data value to that channel. Assign a variable to the data value and display the variable on a status page or floor plan.

The **Log channel data** option may also be selected to view the raw data as it is received in the event log. However, this will create a large number of events and should only be used for verifying the reception of data.

For more information on programming this feature, see the Protege GX Setup Guide.

# Address Configuration

---

Protege modules are set to address 254 at the factory. This is above the address range that the controller supports, so the module will not come online immediately when you connect it to the module network.

To bring the module online, you must set the module address to a valid unused address. See the Protege system controller configuration guide for instructions on how to program the address.

You will need the module's serial number to set the address. You can find the serial number on the identification sticker on the product.

# LED Indicators

---

Protege DIN rail modules feature comprehensive diagnostic indicators that can aid the installer in diagnosing faults and conditions. In some cases an indicator may have multiple meanings depending on the status indicator display at the time.

## Status Indicator

The status indicator displays the module status.

State	Description
Fast flash (green)	Module attempting registration with controller
Slow flash (green)	Module successfully registered with controller
Flashing (red)	Module communications activity

When the fault and status indicators are flashing alternately, the module is in identification mode, enabling the installer to easily identify the module in question. Upon either a module update or the identification time period expiring, the module will return to normal operation.

## Fault Indicator

The fault indicator is lit any time the module is operating in non-standard mode. If the fault indicator is flashing, the module requires a firmware update or is in firmware update mode. When the fault indicator is on, the status indicator will flash an error code.

State	Description
Continuous slow flash (red)	Module is in boot mode awaiting firmware update
Constantly on (red)	Module is in error state and will flash an error code with the status indicator

## Power Indicator

The power indicator is lit whenever the correct module input voltage is applied across the mains input terminals.

State	Description
Constantly on	Correct module input voltage applied
Constantly off	Incorrect module input voltage applied

## V1 Output/V2 Output Indicators

The V1 and V2 output indicators show the status of the 12VDC output.

State	Description
Constantly on (green)	12VDC output operating OK
Constantly off	12VDC output temporarily disabled during bootup
Flashing (red)	12VDC output failure

## Battery Indicator

The battery indicator shows the status of the backup battery.

State	Description (with mains power connected - power indicator on)
Flashing (red)	Backup battery is disconnected
On (red)	Backup battery failed its dynamic battery test
On (green)	Last backup battery dynamic test successful
State	Description (with mains power disconnected - power indicator off)
Flashing (red)	Mains has failed and the PSU is drawing power from the battery. State is Battery Low
Flashing (green)	Mains has failed and the PSU is drawing power from the battery. State is Battery Restore

## Temp Indicator

The temp indicator shows the status of the unit's core temperature.

State	Description
On (red)	Core temperature exceeded. <b>Over Temp Shutdown Activated</b>
Flashing (red)	Core temperature within 10°C of Over Temp Shutdown
On (green)	Core temperature OK

## Output Current Indicator

The output current indicator shows the status of the output current for both V1+ and V2+.

State	Description
First five indicators flashing green Last indicator flashing red	Output current exceeded. <b>Over-current shutdown activated</b>
All indicators flashing green	Output current exceeded maximum, approaching over-current shutdown
All indicators constantly on	Maximum output current level reached
Some indicators constantly on	Indicated output current level reached

# Error Code Indication

---

When the module attempts to register or communicate with the system controller a registration error can be generated indicating that it was not successful.

## Error Code Display

The following table is only valid if the **fault** indicator is constantly on and the **status** indicator is flashing red.

If the fault indicator is flashing the module requires a firmware update or is currently in firmware update mode.

The status indicator will flash red with the error code number. The error code number is shown with a 250ms on and off period (duty cycle) with a delay of 1.5 seconds between each display cycle.

Flash	Error Description
1	<b>Unknown Error Code</b> The error code returned by the system controller could not be understood by the module.
2	<b>Firmware Version</b> The firmware version on the module is not compatible with the system controller. To clear this error, update the module using the module update feature in the controller's web interface.
3	<b>Address Too High</b> The module address is above the maximum number available on the system controller. To clear this error change the address to one within the range set on the system controller, restart the module by disconnecting the power.
4	<b>Address In Use</b> The address is already in use by another module. To clear this error set the address to one that is not currently occupied. Use the view network status command to list the attached devices, or the network update command to refresh the registered device list.
5	<b>Controller Secured Registration Not Allowed</b> The controller is not accepting any module registrations. To allow module registrations use the network secure command to change the setting to not secured.
6	<b>Serial Number Fault</b> The serial number in the device is not valid. Return the unit to the distributor for replacement.
7	<b>Locked Device</b> The module or system controller is a locked device and cannot communicate on the network. Return the unit to the distributor for replacement.

# Maintenance

---

ICT recommends that you complete the following maintenance procedures at least once per year.

Task	Description
Check the equipment schedule and/or maintenance sheets	Check the installation, location and siting of all equipment and devices against the 'as-built' documentation. Record and report any discrepancies.
Check wiring and cable protection	Visually inspect all wiring and cable protection systems (conduits, trunking, etc.). Record any damage or deterioration.
Check for dust, moisture and vermin	Check all equipment enclosures for dust, moisture, condensation and vermin. If excessive moisture or foreign matter is present, clear this out of the enclosure and take steps to prevent future accumulation.
Check the mains connection	Check that all power supplies are properly connected to a mains outlet and are operational.
Test the power supply DC output voltage	Disconnect the backup batteries and test the DC voltages across the V+ and V- output terminals on all power supplies. The recommended voltage range is <b>13.5 - 14.1 VDC</b> .
Check battery connections	Check that the batteries and battery connections show no visible signs of corrosion.
Test battery charge voltage	Test the DC voltage across the spade terminals of the battery. The recommended voltage range is <b>13.3 - 13.9 VDC</b> . When the mains power is restored following an AC fail condition, the battery voltage may be as low as 9.4V as it begins to recharge.
Replace battery	Replace each power supply battery as recommended by the manufacturer. For more information, see <a href="#">Backup Battery</a> (page 16). If the battery needs to be replaced, install a new battery of equivalent or better specifications. If two batteries are connected in parallel, replace both at the same time. Record the installation date of the new battery in the system maintenance records and in a clearly visible location within the equipment enclosure or on the battery itself.

# Troubleshooting

---

This section describes how to diagnose and resolve some issues that may occur with this power supply product.

Trouble inputs can only be used when the power supply is online with a Protege system (see page 33). If the power supply is used offline, you can use the offline status outputs (see page 25).

**The power supply has mains or battery input, but is not supplying power from the output terminals. The power or battery indicator is on, but the V1/V2 output indicators are off.**

When the module boots up, it takes up to 5 seconds to start supplying power to the outputs. Wait for the module to finish booting up.

**The fault indicator is on and the status indicator is flashing. The 'Module Offline' trouble input is activated.**

The module cannot connect to the controller due to a configuration issue. The fault indicator will flash an error code—see [Error Code Display](#).

**The battery indicator is flashing and the power indicator is off. In online mode, the 'Mains Failure' trouble input is activated. In offline mode, the AC fail status output is activated.**

There is no mains power and the power supply is drawing from the battery. If the battery indicator is flashing red, the battery has low voltage—see [Backup Battery Thresholds](#).

**The battery indicator is flashing red and the power indicator is on. In online mode, the 'Low Battery / Battery Failure' trouble input is activated. In offline mode, the battery fail status output is activated.**

The backup battery is disconnected or not connected correctly. See [Connecting the Battery](#).

**The output current indicators are flashing green. The 'Output Over-Current Failure' trouble input is activated.**

Too much current is being drawn from the power supply outputs. The power supply will soon shut down the outputs. Disconnect any short circuits or devices that are drawing excessive current.

**The output current indicators are flashing, with the last indicator flashing red. The 'Output Over-Current Failure' trouble input is activated.**

The power supply has shut down the power outputs due to excessive current draw. Disconnect any short circuits or devices that are drawing excessive current.

**The temp indicator is flashing red. The 'Core Temperature Over-Temp Failure' and 'Output Over-Current Failure' trouble inputs are activated.**

The power supply core temperature is within 10°C of the maximum. It is about to shut down the power outputs. Cool the power supply or disconnect any devices that are drawing excessive current.

**The temp indicator is solid red. The 'Core Temperature Over-Temp Failure' and 'Output Over-Current Failure' trouble inputs are activated.**

The power supply has shut down the power outputs due to exceeding the maximum core temperature. Cool the power supply.

## Firmware Upgrade Failure

When the power supply is online with the Protege system, you can upgrade its firmware from the **Application Software** page in the controller's web interface. Always supervise the power supply during the firmware upgrade process and ensure that it does not lose power.

During the firmware upgrade, all LEDs will be deactivated except for the Fault LED flashing red. When the upgrade is complete, the power supply will reboot. The Power LED will turn on, and the Status LED will flash rapidly for a few seconds, then return to flashing normally.

If the power supply loses power during the upgrade or does not reboot successfully afterwards, you must attempt to recover it using a force update. To perform a force update:

1. In the controller's web interface, navigate to the **Application Software** page.
2. Click **Module** to expand the hidden **Force Update** section.
3. Set the **Force Update - Module** to the power supply model.
4. Set the **Force Update - Address** to the **Physical Address** of the module. You can view this in **Expanders | Analog Expanders**.
5. Click **Upload Firmware**. Browse to the firmware file (.bin format) supplied by ICT and click **Open**.
6. Wait for the power supply to upgrade and reboot.

# Mechanical Diagram

The mechanical diagram shown below outlines the essential details needed to help ensure the correct installation of the power supply.

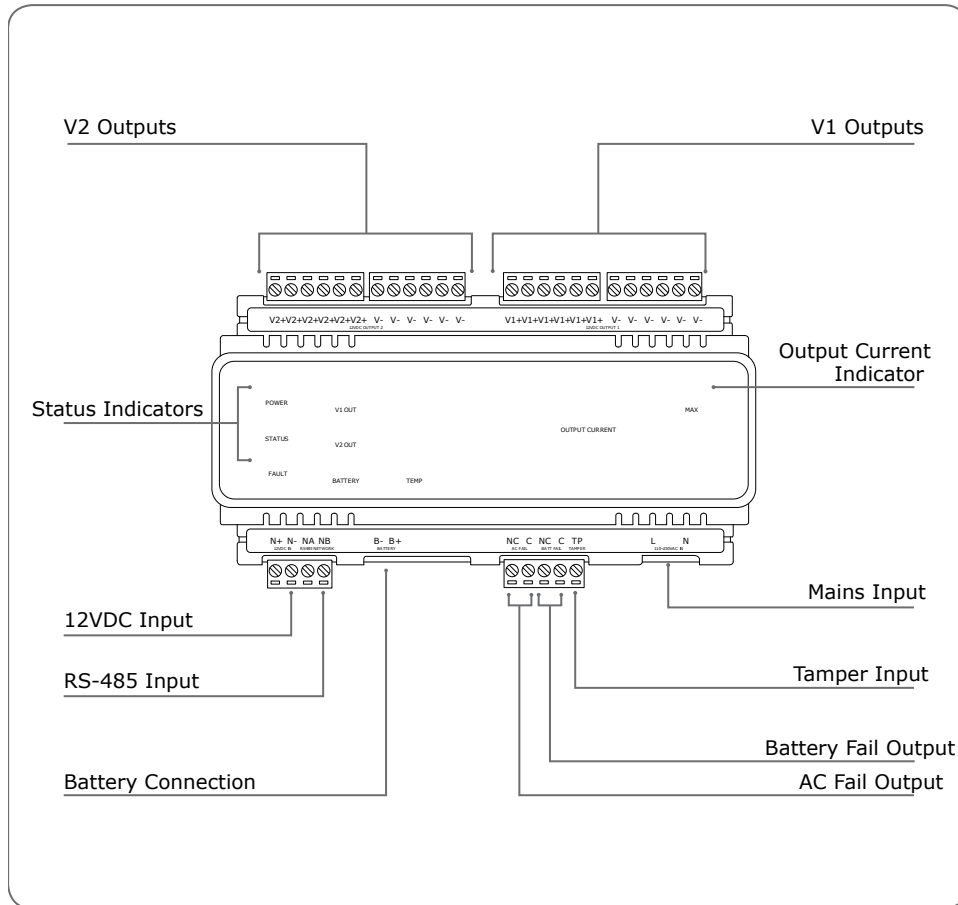

# Mechanical Layout

The mechanical layout below outlines the essential details needed to help ensure correct installation and mounting. All measurements are shown in millimeters.

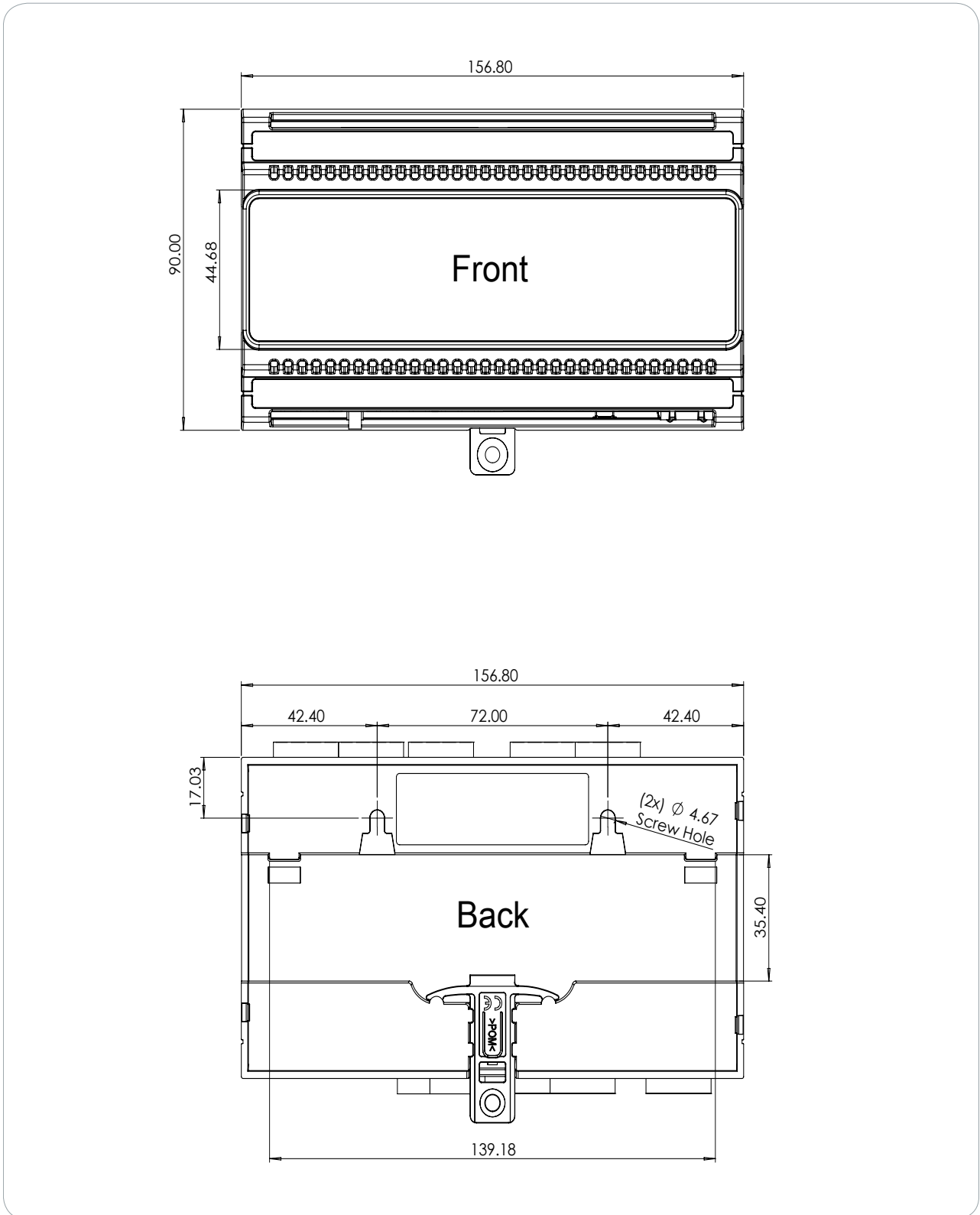

# Technical Specifications

The following specifications are important and vital to the correct operation of this product. Failure to adhere to the specifications will result in any warranty or guarantee that was provided becoming null and void.

Ordering Information	
PRT-PSU-DIN-5A	Protege DIN Rail 5A Intelligent Power Supply
Power Supply	
Mains Input	110-240VAC System (50/60Hz)
Mains Input Operating Current	0.6A (at 240VAC) - 1.1A (at 110VAC)
DC Output Voltage	12VDC System (10.4-14.0VDC)
DC Output Current	5.0A, 13.7VDC UL/cUL: Max. 5.0A including power supply board.
DC Output Transient Overload Current	6A, 13.7VDC
Maximum Overload Current	5.6A
Battery Charging Current	600mA (Typical) 630mA (Maximum) Additional to the DC output.
Battery Low	11.0V
Battery Disconnect	9.4V
Battery Restore	11.0V
Communication	
RS-485	Isolated Module Network
Outputs	
Outputs	2 Solid-State Relay Outputs, 50mA 12V Max each
Inputs	
Tamper	Dedicated Hardware Tamper Input
Trouble Inputs	8 (internal)
Dimensions	
Dimensions (L x W x H)	157 x 90 x 60mm (6.2 x 3.5 x 2.4")
Net Weight	500g (17.6oz)
Gross Weight	610g (21.5oz)
Operating Conditions	
IP Rating	Indoor use only IP50 when installed inside ICT cabinet
Operating Temperature	UL/cUL 0° to 49°C (32° to 120°F) : EU EN -10° to 55°C (14° to 131°F)
Storage Temperature	-10° to 85° C (14° to 185° F)

Humidity	0%-93% non-condensing, indoor use only (relative humidity)
----------	--

It is important that the unit is installed in a dry cool location that is not affected by humidity. Do not locate the unit in air conditioning or a boiler room that can exceed the temperature or humidity specifications.

Integrated Control Technology continually strives to increase the performance of its products. As a result these specifications may change without notice. We recommend consulting our website ([www.ict.co](http://www.ict.co)) for the latest documentation and product information.

# New Zealand and Australia

---

## General Product Statement

The RCM compliance label indicates that the supplier of the device asserts that it complies with all applicable standards.



## ASIAL Class 5

This product is certified for AS/NZS 2201:2007 Class 5 installations as part of a compliant Protege GX or Protege WX system.

For more information, see the Protege GX / Protege WX AS/NZS 2201.1:2007 Class 5 Compliance Installer Guide, available from ICT.

ASIAL compliance has not been evaluated by UL/cUL.

# European Standards

---

## CE Statement

Conforms where applicable to European Union (EU) Low Voltage Directive (LVD) 2014/35/EU, Electromagnetic Compatibility (EMC) Directive 2014/30/EU, Radio Equipment Directive (RED) 2014/53/EU and RoHS Recast (RoHS2) Directive: 2011/65/EU + Amendment Directive (EU) 2015/863.

This equipment complies with the rules, of the Official Journal of the European Union, for governing the Self Declaration of the CE Marking for the European Union as specified in the above directive(s).



### Information on Disposal for Users of Waste Electrical & Electronic Equipment

This symbol on the product(s) and / or accompanying documents means that used electrical and electronic products should not be mixed with general household waste. For proper treatment, recovery and recycling, please take this product(s) to designated collection points where it will be accepted free of charge.

Alternatively, in some countries you may be able to return your products to your local retailer upon purchase of an equivalent new product.

Disposing of this product correctly will help save valuable resources and prevent any potential negative effects on human health and the environment, which could otherwise arise from inappropriate waste handling.

Please contact your local authority for further details of your nearest designated collection point.

Penalties may be applicable for incorrect disposal of this waste, in accordance with your national legislation.

### For business users in the European Union

If you wish to discard electrical and electronic equipment, please contact your dealer or supplier for further information.

### Information on Disposal in other Countries outside the European Union

This symbol is only valid in the European Union. If you wish to discard this product please contact your local authorities or dealer and ask for the correct method of disposal.

## EN50131 Standards

This component meets the requirements and conditions for full compliance with EN50131 series of standards for equipment classification.

EN 50131-1:2006+A2:2017, EN 50131-3:2009, EN 50131-6:2008+A1:2014, EN 50131-10:2014, EN 50136-1:2012, EN 50136-2:2013, EN 60839-11-1:2013

### Security Grade 4

### Environmental Class II

Equipment Class: Fixed

Readers Environmental Class: IVA, IK07

SP1 (PSTN – voice protocol)

SP2 (PSTN – digital protocol)

SP6 (LAN – Ethernet) and DP1 (LAN – Ethernet + PSTN)

SP6 (LAN – Ethernet) and DP1 (LAN – Ethernet + USB-4G modem)

**Tests EMC (operational)** according to EN 55032:2015

**Radiated disturbance** EN 55032:2015

**Power frequency magnetic field immunity tests** (EN 61000-4-8)

**Power Supply Type A** (EN 50130-4 ed. 2)

**Mains supply voltage variations** (EN 50130-4 ed. 2)

**Mains supply voltage dips and short interruption** (EN 50130-4 ed. 2, EN 61000-4-2 ed. 2)

**Electrostatic discharge** (EN 50130-4 ed. 2, EN 61000-4-2 ed. 2)

**Contact discharges**  $\pm 6$  kV, Air discharges to  $\pm 8$  kV

**Radiated electromagnetic fields** (EN 50130-4 ed. 2, EN 61000-4-3 ed.3)

**Conducted disturbances induced by electromagnetic fields** (EN 50130-4 ed. 2, EN 61000-4-6)

**Fast Transient bursts** (EN 50130-4 ed. 2, EN 61000-4-4 ed.2)

To the AC mains supply lines applied disturbance signal voltage level 2 kV both polarities for 1 minute. To other supply / signal lines applied by the capacitive clamp injection method disturbance signal voltage level 1 kV for both polarities for 1 minute.

**Slow high energy voltage surge** (EN 50130-4 ed. 2, EN 61000-4-5 ed.2)

To comply with EN 50131-1, EN 60839-11 Security Grade 4 and AS/NZS2201.1 class 4&5 Vibration Detection for PreTamper Alarm, protection is provided by a DSC SS-102 Shockgard Seismic vibration sensor mounted within the system enclosure. Alarm output is provided by a pair of non-latching, N.C. (normally closed) relay contacts, opening for a minimum of 1 second on detection of an alarm connected in series with the 24Hr tamper input (TP) on the PSU (or any other system input designated/programmed as a 24Hr Tamper Alarm).

This relay is normally energized to give fail-safe operation in the event of a power loss. Indication of detection is provided by a LED situated on the front cover. The vibration sensor is fully protected from tampering by a N.C. micro switch operated by removal of the cover.

Enclosure EN-DIN-24 has been tested and certified to EN50131.

By design, the enclosures for all Integrated Control Technology products, EN-DIN-11, EN-DIN-12 and , comply with the EN 50131 standards. Tamper protection against removal of the cover as well as removal from mounting is provided by tamper switch.

**Warning: Enclosures supplied by 3rd parties may not be EN50131-compliant, and should not be claimed as such.**

To comply with EN 50131-1, only one battery can be connected and monitored per system. If more capacity is required, a single larger battery must be used.

EN compliance has not been evaluated by UL/cUL.

# UL and cUL Installation Requirements

---

Only UL / cUL listed compatible products are intended to be connected to a UL / cUL listed control system.

## UL/cUL Enclosures

All UL/cUL installations must use an enclosure (cabinet) that is listed to the relevant UL or cUL standard.

ICT offers a range of UL- and cUL-listed enclosures that are suitable for installation of Protege DIN rail products and accessories such as batteries. For our enclosure listings, see one of the following locations:

- The UL/cUL-Listed Protege Enclosures reference document, available from the ICT website.
- [UL Product iQ](#)

## UL/cUL Firmware Version

UL/cUL has validated this power supply with firmware version 2.00.XXXX.

To view the firmware version of your power supply:

1. Connect the power supply to a Protege controller via the RS-485 module network.
2. Log in to the controller's web interface.
3. Navigate to **Application Software**.
4. Under **Update Module Firmware**, expand the **Module** dropdown. This displays the address, serial number and current firmware version of each module connected to the controller. Use the power supply's address or serial number to identify its firmware version.

## cUL Compliance Requirements

### CAN/ULC-60839-11-1

- The Protege controller and reader expander module are intended to be mounted within the enclosure (refer to UL/cUL Installation Cabinet Options), installed inside the protected premise, and are CAN/ULC-60839-11-1 Listed for Class I applications only.
- Exit devices and wiring must be installed within the protected area.
- For the Protege controller and reader expander module, all RS-485 and reader terminal connections must be made using shielded grounded cable.
- All readers must be connected with shielded, grounded cable.
- A bell or visual indicator used as an arming acknowledgment signal must be listed to a cUL security, signaling or fire standard. If intended to be mounted outside, it must be rated for outdoor use.
- Fail secure locking mechanisms shall only be installed where allowed by the local authority having jurisdiction (AHJ) and shall not impair the operation of panic hardware and emergency egress.
- If fire resistance is required for door assembly, portal locking device(s) must be evaluated to ULC-S533 and CAN/ULC-S104.
- Must be installed with CAN/ULC-60839-11-1 listed portal locking device(s) for cUL installations.
- If a flexible cord is used to connect to line voltage, strain relief must be provided for the cord inside the enclosure or at the knockout.
- The power supply is not intended to be mounted on the exterior of vault, safe, or stockroom.

# CAN/ULC-S304

- **Auto Arming**

Control units that support auto arming shall provide an audible signal throughout the protected area not less than 10 min prior to the auto arming taking place. The control unit shall allow authorized users to cancel the auto arming sequence and transmit such cancelation to the signal receiving center with the identification of the authorized user that canceled the action.

The following options must be enabled in the Protege system when using the Auto Arming feature. When the defer warning time is programmed to 10 minutes, the output group will be activated 10 minutes before the system performs the Auto Arming in the associated Area.

- The **Defer Output or Output Group** must be programmed. Refer to the section Areas | Outputs in the Operator Reference Manual for programming instructions.
- The **Defer Warning Time** must be programmed to not less than 10 minutes. Refer to the section Areas | Configuration in the Operator Reference Manual.
- The **Defer Automatic Arming** option must be enabled. Refer to the section Areas | Options (2) in the Operator Reference Manual.

- **Arming Signal**

A bell or visual indicator used as an arming acknowledgment signal must be listed to a cUL security, signaling or fire standard. If intended to be mounted outside, it must be rated for outdoor use.

- **Double EOL Input Configuration**

Only double EOL Input Configuration shall be used. Refer to the Inputs section of this manual and the section Inputs | Options in the Operator Reference Manual.

- **Multiplex System and Poll Time**

The Protege controller is compatible with the ArmorIP Internet Monitoring Receiver. Poll Time must be set to 40 seconds and the Grace Time must be set to 20 seconds.

In the Protege system, the reporting service must be configured to 40 seconds. The following options are required for the service selected as Report IP type:

- The **Log Polling Message** option must be enabled. Refer to the section Report IP | Options in the Operator Reference Manual.
- The **Poll Time** must be programmed to 40 seconds. Refer to the Report IP | General section in the Operator Reference Manual.

- **Central Station Signal Receiver**

The common equipment of each signal receiving center control unit shall be limited to 1000 alarm systems.

- **Number of attempts**

In the event of unsuccessful communication, a digital alarm communicator transmitter shall make a minimum of 5 and a maximum of 10 attempts. Where the maximum number of attempts to complete the sequence is reached, an indication of the failure shall be made at the premises.

In the Protege system, the reporting service selected as Contact ID must have the number of attempts programmed to 5 attempts. The **Dial Attempts** option must be programmed. Refer to the section Contact ID | Settings in the Operator Reference Manual.

If the PRT-4G-USB cellular modem is being used as the secondary reporting option in the installation, the Report IP service assigned to the cellular modem must be programmed as above.

- **Check-In Time**

DACT communication channel check-in time is not to exceed 24 hrs.

- **Trouble Input Service Test Report**

- The **Test Report Time** must be programmed. Refer to the section Controllers | Configuration in the Operator Reference Manual.
- The **Generate Input Restore on Test Input** option must be enabled. Refer to the section Controller | Options in the Operator Reference Manual.
- The **Test Report Time is Periodic** option must be enabled. Refer to the section Controller | Options in the Operator Reference Manual.

- **Primary Communication Channel**

The first attempt to send a status change signal shall utilize the primary communication channel.

An ethernet Report IP service must be used as the primary service. The backup service may use Contact ID over the phone line or Report IP over the cellular network if the PRT-4G-USB cellular modem is being used as the secondary communication channel.

The following options are required:

- The primary service (Report IP) must have the **Backup service** set to the secondary reporting service (Contact ID or Report IP over 4G modem). The **Service mode** must be set to 1 - Start with controller OS.
- The backup service must have **Service operates as backup** enabled. For ULC-S304 P3 applications, **Enable offline polling** must be enabled and configured so that the backup service is monitored even when it is not active.
- For Report IP services, the **Reporting protocol** must be set to Armor IP.
- Refer to the Services section in the Operator Reference Manual.

- **Status Change Signal**

An attempt to send a status change signal shall utilize both primary and secondary communication channels.

- **Local Annunciation if Signal Reporting Failure**

Failure of the primary communication channel or secondary communication channel shall result in a trouble signal being transmitted to the signal receiving center within 240 seconds of the detection of the fault. Failure of either communication channel shall be annunciated locally within 180 seconds of the fault.

The following options must be enabled in the Protege system:

- The **Ethernet Link Failure** trouble input must be programmed.
- The **Trouble Input Area** must be armed. Refer to the section Trouble Inputs | Areas and Input Types in the Operator Reference Manual.

- **Network and Domain Access**

Neither the subscriber control unit nor the signal receiving center receiver shall be susceptible to security breaches in general-purpose operating systems.

Network access policies should be set to restrict unauthorized network access and "spoofing" or "denial of service" attacks.

- **Ethernet Connections**

All ethernet network connections shall be installed within the same room as the equipment.

- **Encryption**

For active communications channel security, encryption shall be enabled at all times.

The ArmorIP-E (UDP or TCP) protocol must be used and the Encryption Type must be set to AES-256.

The following options must be enabled for the Report IP service in the Protege system.

- The **Reporting Protocol** must be set to ArmorIP (UDP) Encrypted or ArmorIP (TCP) Encrypted. The AES key must be set as specified by monitoring station.
- Refer to the section Report IP | General in the Operator Reference Manual.

- **Server Configuration**

Where a server is employed for control over network addressing, encryption or re-transmission, such shall be designed to remain in the "on state" at all times.

Communicators are not suitable for active communication channel security and medium or high risk applications unless such can be "online" at all times, have a minimum 128 bit encryption scheme, have encryption enabled, network and domain security implemented.

Network access policies shall be set to restrict unauthorized network access and "spoofing" or "denial of service" attacks.

- **Internet Service Provider (ISP)**

The Internet Service Provider (ISP) providing service shall meet the following requirements:

- redundant servers/systems
- back-up power

- routers with firewalls enabled and
- methods to identify and protect against "Denial of Service" attacks (i.e. via "spoofing")
- **Information Technology Equipment, Products or Components of Products**  
 Products or components of products, which perform communications functions only, shall comply with the requirements applicable to communications equipment as specified in CAN/CSA-C22.2 No. 62368-1, Audio/video, information and communication technology equipment - Part 1: Safety requirements. Where network interfaces, such as the following, are internal to the subscriber control unit or receiver, compliance to CAN/CSA-C22.2 No. 62368-1 is adequate. Such components include, but are not limited to:
  - A) Hubs;
  - B) Routers;
  - C) Network interface devices;
  - D) Third-party communications service providers;
  - E) Digital subscriber line (DSL) modems; and
  - F) Cable modems.
- **Backup Power Requirements**  
 Power for network equipment such as hubs, switchers, routers, servers, modems, etc., shall be backed up or powered by an uninterruptible power supply (UPS), stand-by battery or the control unit, capable of facilitating 24h standby, compliant with Clauses 16.1.2 and 16.4.1 of CAN/ULC-S304.  
 For communications equipment employed at the protected premises or signal receiving center and intended to facilitate packet switched communications, as defined in CAN/ULC-S304, 24h back-up power is required.
- **Compromise Attempt Events**  
 ArmorIP detects the reception of any invalid packet on the programmed port as a potential system **compromise attempt**. Each compromise attempt sends a notification to the receiver, and logs a Compromise Attempt event under the Live Panel Events.  
 The event is sent with the following details:
  - **Account Code** as defined in the Serial Receiver settings
  - **Event Code** 0x163
  - **Group Code** as defined in the Serial Receiver settings
  - **Point Code** as defined in the Serial Receiver settings
 Refer to the section [Global Settings | Serial Receiver](#) in the ArmorIP Version 3 Internet Monitoring Application User Manual.  
 For UL and cUL installations the Central Station Receiving software must have the Contact ID details as specified, programmed for the **Compromise Attempt** event.
- **Power Supply Mains Power Connection**  
 If a flexible cord is used to connect to line voltage, strain relief must be provided for the cord inside the enclosure or at the knockout.  
 The power supply is not intended to be mounted on the exterior of vault, safe, or stockroom.

## CAN/ULC-S559

### Signal Reporting

The reporting services and other components shall be programmed so as to meet the requirements of CAN/ULC-S559 for either an active or passive communication system.

This includes the following provisions:

- All signals must be transmitted to the fire signal receiving center within 60 seconds.
- An active communication system shall use one or more IP reporting services. Any fault in the primary reporting service must be detected and annunciated at the fire signal receiving center within 180 seconds.
- IP reporting services may utilize either the controller's onboard ethernet or the PRT-4G-USB cellular modem. The **Reporting Protocol** must be set to ArmorIP with at least 128 bit encryption. Either UDP or TCP may be used.

- A passive communication system shall use two or more communication channels. The primary channel is a Contact ID service over the phone line, with a test signal sent at least every 6 hours. The phone dialer must make a minimum of 5 and a maximum of 10 attempts to dial the receiving center in the event of a communication failure.
- In passive systems, a DAYR7-listed cellular alarm communicator (e.g. DSC LE4010) must provide the backup channel and phone line integrity monitoring. The alarm communicator must be installed and configured in accordance with the manufacturer's instructions for CAN/ULC-S559 (commercial fire reporting) installations.

Further details and programming instructions are provided in Application Note 362: CAN/ULC-S559 Fire Reporting in Protege Systems.

### **Central Station Signal Receiver**

The signal receiving software must be ICT ArmorIP Version 3. It must meet the following requirements:

- The **Poll Time** must be set to 40 seconds and the **Poll Grace Time** must be set to 20 seconds.
- The maximum number of signal transmitting units connected to the ArmorIP Receiver shall not exceed 10000 simultaneous connections.
- The system shall be redundant. For up to 1000 accounts, two computers must be used. Each subsequent set of 1000 accounts requires another two computers.

For instructions and hardware requirements, see the ArmorIP Version 3 Internet Monitoring Application User Manual.

### **Ethernet Connections**

All ethernet network connections shall be installed within the same room as the equipment.

### **External Wiring**

All wiring extending outside of the enclosure must be protected by metal conduits.

### **Power Supply Mains Power Connection**

If a flexible cord is used to connect to line voltage, strain relief must be provided for the cord inside the enclosure or at the knockout.

The power supply is not intended to be mounted on the exterior of vault, safe, or stockroom.

### **Backup Power**

See your power supply installation manual for backup battery power requirements for the Protege system.

Telecom equipment (switches, modems, routers) requires 24hr of standby backup power.

### **Arming Signal**

A bell or visual indicator used as an arming acknowledgment signal must be listed to a cUL security, signaling or fire standard. If intended to be mounted outside, it must be rated for outdoor use.

### **Keypad Wiring**

The RS-485 connection to the keypad must be wired such that the shorts and other faults on the RS-485 line connection of the keypad will not cause the controller to malfunction.

### **Fire Zone Inputs**

Inputs 1, 2 and 3 on the controller or input expander must be connected to the Fire, Supervisory and Trouble outputs on the fire alarm control panel, as indicated in the diagrams below.

- EOL resistors must be installed at the fire alarm control panel outputs. Typical input circuits are:

Value 1	Value 2	Monitored Status
1k	1k	Open, Closed, Tamper, Short
6k8	2k2	Open, Closed, Tamper, Short
10k	10k	Open, Closed, Tamper, Short
2k2	2k2	Open, Closed, Tamper, Short
4k7	2k2	Open, Closed, Tamper, Short
4k7	4k7	Open, Closed, Tamper, Short

See the Inputs section of the controller or expander installation manual for connection diagrams.

- These inputs must have a fire area assigned, and the area must be armed. Areas used for fire reporting must not also be used for burglary.
- These inputs must be used exclusively for fire monitoring and cannot be programmed to activate the bell output.

Further details and programming instructions are provided in Application Note 362: CAN/ULC-S559 Fire Reporting in Protege Systems.

### Trouble Monitoring

The following trouble inputs must have the system area assigned with the Trouble Silent input type.

- Controller Service Report Test
- Controller ContactID Reporting Failure
- Controller ReportIP Reporting Failure
- Power Supply (Analog Expander) Mains Failure

The 24 hour portion of the system area must be armed at all times.

Provided that the Power Supply Mains Failure trouble input is monitored and reported to the receiving center, it is not necessary to display a visible LED indication outside the cabinet when there is a mains power failure.

Further details and programming instructions are provided in Application Note 362: CAN/ULC-S559 Fire Reporting in Protege Systems.

### Indicating Reporting Failures

Reporting failures must be indicated on the user interface for the system. There are two methods for achieving this:

- Sites with keypads can display the trouble message on the keypad.
- If the fire alarm control panel has an COM Status input, it may be connected to any available dry relay contact on the controller or output expander. When there is a reporting failure, the relay will turn on to activate the COM Status indicator on the fire alarm control panel.

Depending on how this relay is programmed, it may latch on when a reporting failure occurs. If so, a normally open monitoring reset button must be provided on controller input 4 to reset the relay output.

Further details and programming instructions are provided in Application Note 362: CAN/ULC-S559 Fire Reporting in Protege Systems.

# Active/Passive Communication System Diagrams

## CAN/ULC-S559 CONTROLLER ACTIVE COMMUNICATION

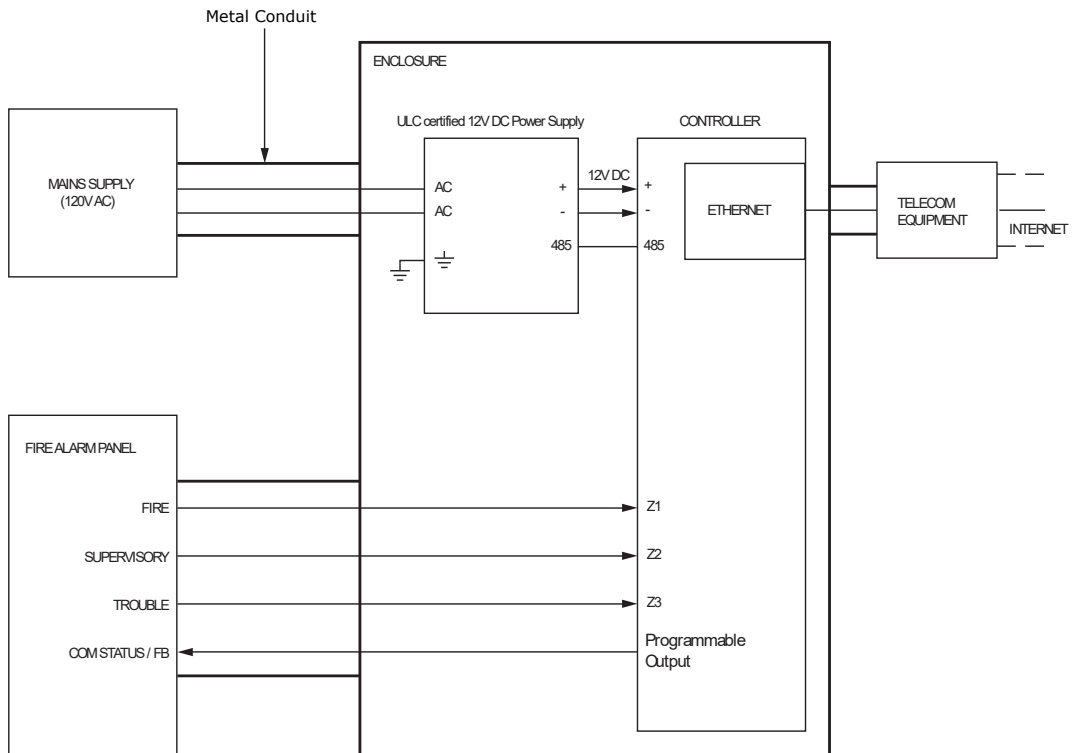

## CAN/ULC-S559 CONTROLLER ACTIVE COMMUNICATION: CELLULAR MODEM

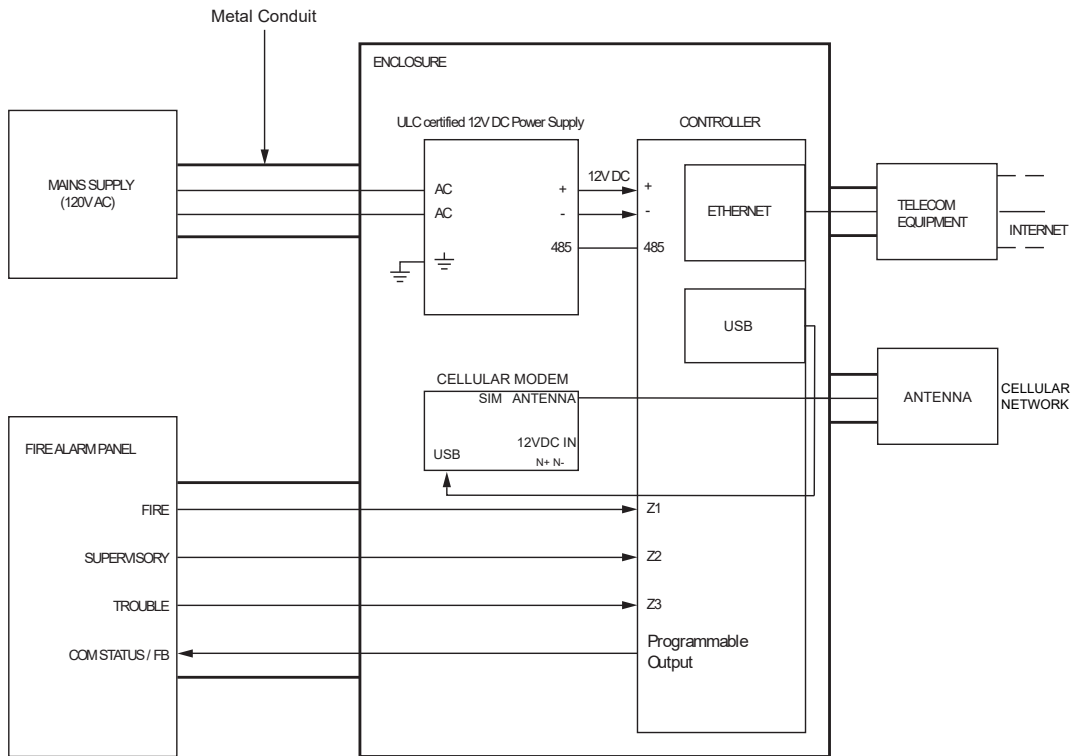

CAN/ULC-S559  
 CONTROLLER  
 PASSIVE COMMUNICATION: MODEM DIALER

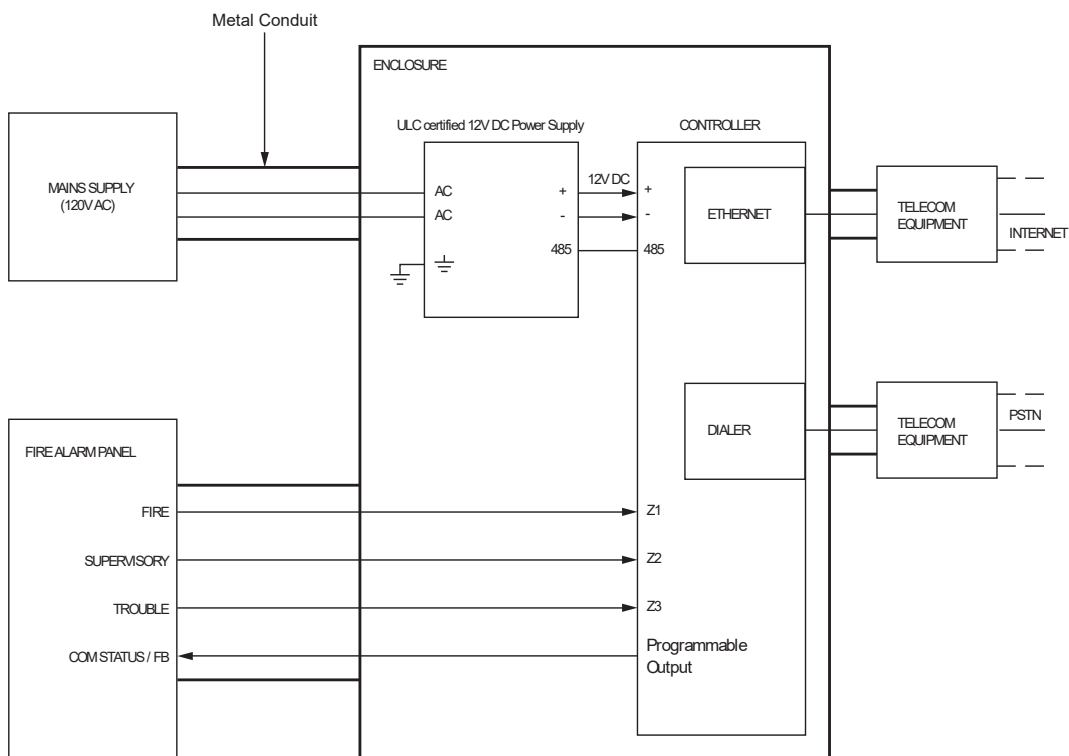

## UL Compliance Requirements

### UL294

- The Protege controller and reader expander module are intended to be mounted within the enclosure (refer to UL/cUL Installation Cabinet Options), installed inside the protected premise, and are UL 294 Listed for Attack Class I applications only.
- Exit devices and wiring must be installed within the protected area.
- For the Protege controller and reader expander module, all RS485 and reader terminal connections must be made using shielded grounded cable.
- All readers must be connected with shielded, grounded cable.
- A bell or visual indicator used as an arming acknowledgment signal must be listed to a UL security, signaling or fire standard. If intended to be mounted outside, it must be rated for outdoor use.
- Fail secure locking mechanism shall only be installed where allowed by the local authority having jurisdiction (AHJ) and shall not impair the operation of panic hardware and emergency egress.
- If fire resistance is required for door assembly, portal locking device(s) must be evaluated to UL10B or UL10C.
- Must be installed with UL 1034 listed electronic locks for UL installations.
- AC power on shall be indicated by an external panel mount LED (Lumex SSI-LXH312GD-150) and fitted into a dedicated 4mm hole in the cabinet to provide external visibility. This shall be wired between 12V and a PGM output that is programmed to follow the AC trouble input as shown below:

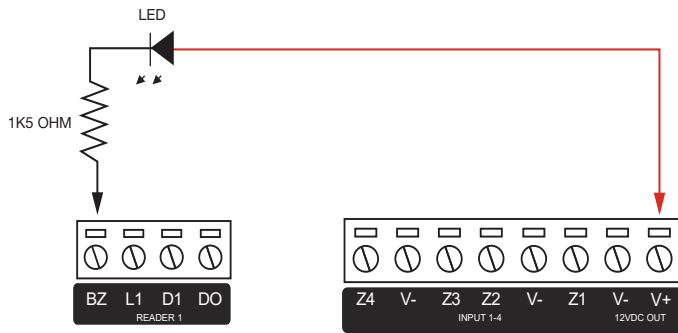

- If a flexible cord is used to connect to line voltage, strain relief must be provided for the cord inside the enclosure or at the knockout.
- The power supply is not intended to be mounted on the exterior of vault, safe, or stockroom.
- **Endurance Level:** III (50,000 cycles)

## UL2610

This power supply is certified to UL2610 for Mercantile applications. It may be used as part of a security system on a commercial premises alongside a UL2610- or UL1610-listed controller.

Protege controllers are certified to UL1610. See the installation manual for your Protege controller for more requirements for installing a compliant commercial security system.

### Printed Copy of Installation Manual

If you require a printed copy of these instructions, use the **Print** button in your PDF reader software.

### Enclosure

For UL2610 applications, the power supply must be installed in a UL2610-listed enclosure.

### Tamper Switch

The cabinet tamper switch must be connected and monitored as outlined in Cabinet Tamper Switch.

### Power Supply Monitoring

A malfunction of the power supply, or loss of either primary power or standby battery capability, shall result in an alarm or trouble signal. To achieve this, use one of the following methods:

- **Online with the Protege RS-485 module network:** Assign the 'Mains Failure' and 'Low Battery/Battery Failure' trouble inputs to the System Area with the input type 'Trouble Silent'. Refer to the operator manual for your system for more information.
- **Offline mode:** Wire the AC Fail and Battery Fail status outputs to the alarm inputs of a UL2610-listed controller.

### Alarm Sounding Device

The power supply is not approved to provide backup power to an alarm sounding device for UL2610. Use a UL-listed alarm sounding device with an independent battery capable of providing 15 minutes of backup power.

# FCC Compliance Statements

---

## FCC Rules and Regulations CFR 47, Part 15, Subpart B

This equipment complies with the limits for a Class A digital device, pursuant to Part 15 of the FCC rules.

Operation is subject to the following two conditions:

- This device may not cause harmful interference.
- This device must accept any interference received, including interference that may cause undesired operation.

NOTE: THE GRANTEE IS NOT RESPONSIBLE FOR ANY CHANGES OR MODIFICATIONS NOT EXPRESSLY APPROVED BY THE PARTY RESPONSIBLE FOR COMPLIANCE. SUCH MODIFICATIONS COULD VOID THE USER'S AUTHORITY TO OPERATE THE EQUIPMENT.

# Industry Canada Statement

---

## ICES-003

This class A digital apparatus complies with Canadian ICES-003.

Cet appareil numérique de la classe A est conforme à la norme NMB-003 du Canada.

CAN ICES-3 (A)/NMB-3(A)

# IEC 62368-1:2020

---

This power supply has been tested and confirmed to comply with IEC 62368-1. This satisfies the requirements for:

- Australia/New Zealand: AS/NZS 62368-1
- Canada/USA: CSA/UL 62368-1
- Europe: EN 62368-1
- Great Britain: BS EN 62368-1
- Japan: J62368-1

# Disclaimer and Warranty

---

**Disclaimer:** Whilst every effort has been made to ensure accuracy in the representation of this product, neither Integrated Control Technology Ltd nor its employees shall be liable under any circumstances to any party in respect of decisions or actions they may make as a result of using this information. In accordance with the ICT policy of enhanced development, design and specifications are subject to change without notice.

For warranty information, see our [Standard Product Warranty](#).

Designers & manufacturers of integrated electronic access control, security and automation products.  
Designed & manufactured by Integrated Control Technology Ltd.  
Copyright © Integrated Control Technology Limited 2003-2026. All rights reserved.

**Disclaimer:** Whilst every effort has been made to ensure accuracy in the representation of this product, neither Integrated Control Technology Ltd nor its employees shall be liable under any circumstances to any party in respect of decisions or actions they may make as a result of using this information. In accordance with the ICT policy of enhanced development, design and specifications are subject to change without notice.